

# Soft starters

Altistart 48 soft start - soft stop units

<< Back

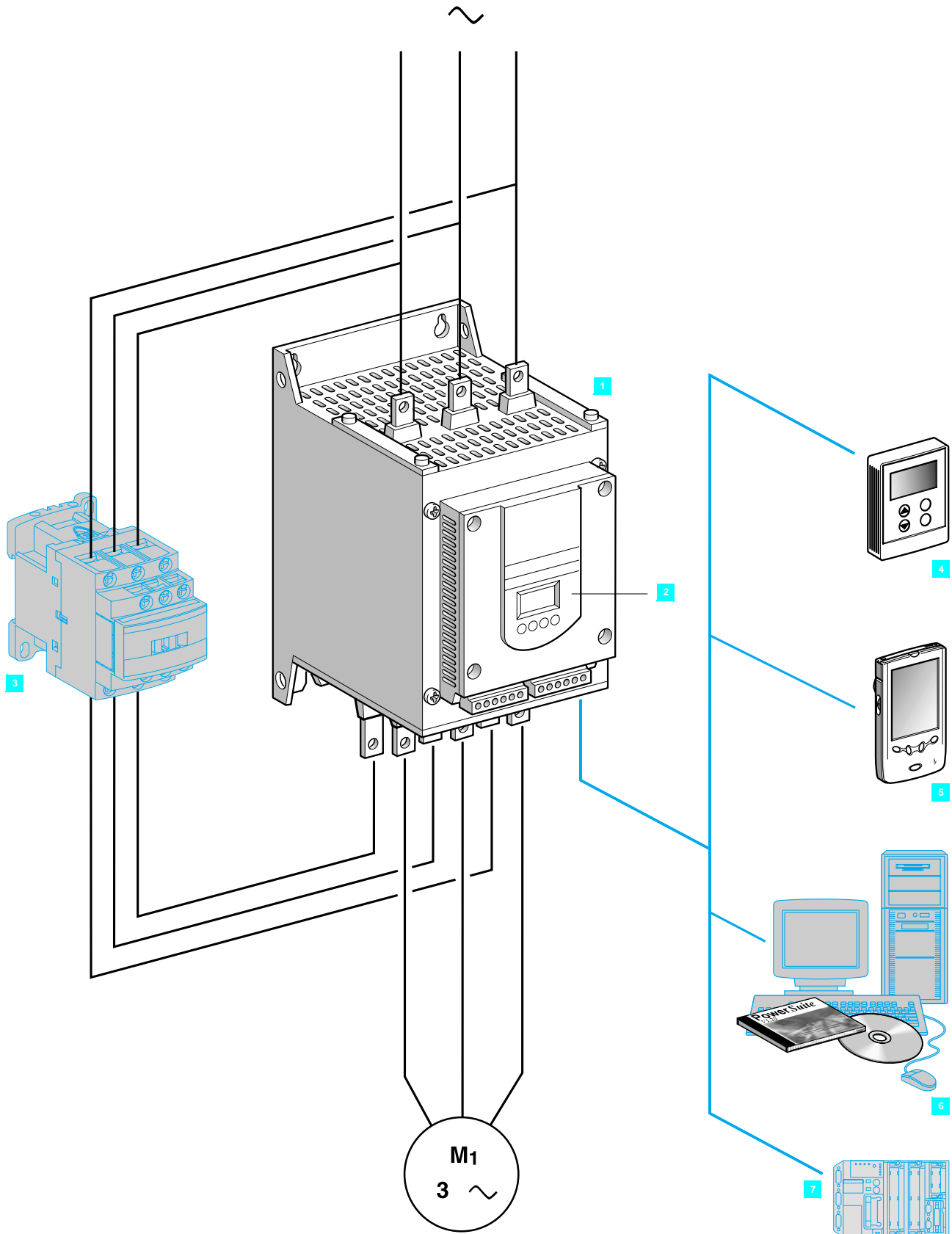

# Soft starters

## Altistart 48 soft start - soft stop units

### Applications

The Altistart 48 soft start - soft stop unit is a controller with 6 thyristors which is used for the torque-controlled soft starting and stopping of three-phase squirrel cage asynchronous motors in the power range between 4 and 1200 kW.

It offers soft starting and deceleration functions along with machine and motor protection functions as well as functions for communicating with control systems. These functions are designed for use in state-of-the-art applications in centrifugal machines, pumps, fans, compressors and conveyors, which are primarily to be found in the construction, food and beverages and chemical industries. The high-performance algorithms of the Altistart 48 contribute significantly to its robustness, safety and ease of setup.

The Altistart 48 soft start - soft stop unit is a cost-effective solution which can:

- Reduce machine operating costs by reducing mechanical stress and improving machine availability
- Reduce the stress placed on the electrical distribution system by reducing line current peaks and voltage drops during motor starts

The Altistart soft start - soft stop unit offer comprises 2 ranges:

- Three-phase voltages 230 to 415 V, 50/60 Hz
- Three-phase voltages 208 to 690 V, 50/60 Hz

In each voltage range, the Altistart soft start - soft stop units are dimensioned for standard and severe applications.

### Functions

The Altistart 48 soft start - soft stop unit (1) is supplied ready for use in a standard application with motor protection class 10 (see page 60526/5).

It comprises a built-in terminal (2) which can be used to modify programming, adjustment or monitoring functions in order to adapt and customise the application to meet individual customer requirements.

#### ■ Drive performance functions:

- Exclusive Altistart torque control (patented by Schneider Electric)
- Constant control of the torque supplied to the motor during acceleration and deceleration periods (significantly reducing pressure surges)
- Facility for adjusting the ramp and the starting torque
- The starter can be bypassed using a contactor (3) at the end of the starting period whilst maintaining electronic protection (bypass function)
- Wide frequency tolerance for generator set power supplies
- The starter can be connected to the motor delta terminals in series with each winding

#### ■ Machine and motor protection functions:

- Built-in motor thermal protection
- Processing of information from PTC thermal probes
- Monitoring of the starting time
- Motor preheating function
- Protection against underloads and overcurrents during continuous operation

#### ■ Functions facilitating the integration of the unit into control systems:

- 4 logic inputs, 2 logic outputs, 3 relay outputs and 1 analogue output
- Plug-in I/O connectors
- Function for configuring a second motor and easy-to-adapt settings
- Display of electrical values, the state of the load and the operating time
- RS 485 serial link for connection to Modbus

### Options

A remote terminal (4) can be mounted on the door of a wall-fixing or floor-standing enclosure.

PowerSuite advanced dialogue solutions:

- PowerSuite Pocket PC with PPC type terminal (5),
- PowerSuite software workshop (6).

A range of wiring accessories for connecting the starter to PLCs via a Modbus connection (7).

Bus communication and Ethernet, Fipio, DeviceNet and Profibus DP network communication options

### Environment

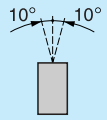
|  |  |            |  |
|--|--|------------|--|
| Conformity to standards  |  |            | The electronic starters have been developed and performance tested in accordance with international standards, in particular with the starter product standard EN/IEC 60947-4-2. |
| CE marking   |  |            | Products have CE marking in accordance with the harmonised standard EN/IEC 60947-4-2.  |
| Product approvals  |  |            | UL, CSA<br>Pending: DNV, C-Tick, Gost, CCIB  |
| Degree of protection   | Starters ATS 48D17● to 48C11●<br>Starters ATS 48C14● to 48M12●<br>(1)  |            | IP 20 (IP 00 in the absence of connections)<br>IP 00   |
| Vibration resistance   | Conforming to IEC 60068-2-6  |            | 1.5 mm from 2 to 13 Hz<br>1gn from 13 to 200 Hz  |
| Shock resistance   | Conforming to IEC 60068-2-27   |            | 15 g for 11 ms   |
| Starter noise level (2)  | Starters ATS 48D32● to D47●<br>Starters ATS 48D62● to C11●<br>Starters ATS 48C14● to C17●<br>Starters ATS 48C21● to C32●<br>Starters ATS 48C41● to C66●<br>Starters ATS 48C79● to M12● | <b>dBA</b> | 52<br>58<br>50<br>54<br>55<br>60   |
| Fans   | Starters ATS 48D17● and D22●<br>Starters ATS 48D32● to M12●  |            | Natural convection<br>Forced convection. The fans are activated automatically when a temperature threshold is reached.<br>For flow rate see page 60523/5.                        |
| Ambient temperature around the unit  | Operation<br>Storage, conforming to IEC 60947-4-2  | °C         | - 10...+ 40 without derating (between + 40 and + 60, derate the nominal current of the Altistart by 2% for each °C).<br>- 25...+ 70  |
| Maximum relative humidity  | Conforming to IEC 60068-2-3  |            | 95% without condensation or dripping water   |
| Maximum ambient pollution  | Conforming to IEC 60664-1  |            | Level 3  |
| Maximum operating altitude   |  | m          | 1000 without derating (above this, derate the nominal current of the Altistart by 2.2% for each additional 100 m). Limit to 2000 m.  |
| Operating position<br>Maximum permanent angle in relation to the normal vertical mounting position |  |            |   |

### Electrical characteristics

|  |  |                           |  |
|--|--|---------------------------|--|
| Operating category   | Conforming to IEC 60947-4-2  |                           | AC-53a   |
| Three-phase supply voltage                                   | Starters ATS 48●●●Q<br>Starters ATS 48●●●Y   | <b>V</b>                  | 230 -15% to 415 + 10%<br>208 - 15% to 690 + 10%                      |
| Frequency  |  | <b>Hz</b>                 | 50/60 ± 5% (automatic)<br>50 or 60 ± 20% (must be set)               |
| Nominal starter current                                      | Starters ATS 48●●●Q<br>Starters ATS 48●●●Y   | <b>A</b>                  | 17...1200<br>17 to 1200  |
| Motor power  | Starters ATS 48●●●Q<br>Starters ATS 48●●●Y   | <b>kW</b><br><b>kW/HP</b> | 4 to 630<br>5.5 to 900/5 to 1200                                     |
| Voltage indicated on the motor rating plate                  | Starters ATS 48●●●Q<br>Starters ATS 48●●●Y   | <b>V</b>                  | 230 to 415<br>208 to 690   |
| Starter control circuit supply voltage                       | Starters ATS 48●●●Q<br>Starters ATS 48●●●Y   | <b>V</b>                  | 220 - 15% to 415 + 10%, 50/60 Hz<br>110 - 15% to 230 + 10%, 50/60 Hz |
| Maximum control circuit consumption<br>(with fans operating) | Starters ATS 48D17● to C17●<br>Starters ATS 48C21● to C32●<br>Starters ATS 48C41● to M12●  | <b>W</b>                  | 30<br>50<br>80   |
| Relay output (2 configurable outputs)                        | 3 relay outputs (R1, R2, R3), normally open contacts 1"N/O"<br>Minimum switching capacity: 10 mA for ~ 6 V.<br>Maximum switching capacity on inductive load: 1.8 A for ~ 230 V and ~ 30 V (cos φ= 0.5 and L/R=20ms). Maximum nominal operating voltage ~ 400 V.<br>Factory setting: R1 assigned as the "fault relay" (configurable)<br>R2 assigned as the "end of starting relay" to control the starter bypass relay<br>R3 assigned as "motor powered" (configurable) |                           |  |

(1) Protective covers can be fitted to the power terminals of ATS 48C14● to C32● starters. ATS 48C41● to 48M12● starters have protection on the front panel and on the sides.

(2) Starters located 1 m away. The noise levels may change depending on the characteristics of the fans.

### Electrical characteristics (continued)

|   |                                |   |
|---|--------------------------------|---|
| Logic inputs LI (2 configurable inputs) |                                | 4 logic inputs, impedance 4.3 kΩ, isolated: Stop, Run, LI3, LI4.<br>+ 24 V power supply (maximum 30 V) I max. 8 mA<br>State 0 if U < 5 V and I < 2 mA<br>State 1 if U > 11 V and I > 5 mA   |
| Internal source available               |                                | 1 x + 24 V output, isolated and protected against short-circuits and overloads.<br>Accuracy ± 25%. Max. current 200 mA.   |
| Logic outputs LO (configurable)         |                                | 2 logic outputs LO1 and LO2 with 0 V common, compatible with level 1 PLC, according to standard IEC 65A-68.<br>+ 24 V power supply (minimum: +12 V, maximum: + 30 V).<br>Maximum output current: 200 mA if supplied externally  |
| Analogue output AO (configurable)       |                                | Current output 0-20 mA or 4-20 mA<br>Maximum load impedance: 500 Ω<br>Accuracy ± 5% of the maximum value  |
| Input for PTC probe                     |                                | Total resistance of probe circuit 750 Ω at 25°C, according to IEC 60 738-A  |
| Maximum I/O connection capacity         |                                | 2.5 mm <sup>2</sup> (AWG 12)  |
| Communication                           |                                | RS 485 multidrop serial link integrated in the starter, for Modbus, with RJ45 type connector<br>Transmission speed 4800, 9600 or 19200 bps<br>Maximum number of Altistart 48 connected: 18<br>Other uses:<br>- connection to a remote terminal or<br>- connection to a PC or<br>- connection to other buses and networks via communication options. |
| Protection                              | Thermal                        | Built-in, starter and motor (calculated and/or thermal protection with PTC probes)  |
|   | Line protection                | Phase failure, indicated by output relay  |
| Current settings                        |                                | The nominal motor current I <sub>n</sub> can be adjusted from 0.4 to 1.3 times the starter nominal current.<br>Adjustment of the maximum starting current from 1.5 to 7 times the motor I <sub>n</sub> , limited to 5 times the starter nominal current.  |
| Starting mode                           |                                | By torque control with starter current limited to 5 I <sub>n</sub> maximum.<br>Factory setting: 4 I <sub>n</sub> for standard operation on 15 s torque ramp   |
| Stopping mode                           | Freewheel stop                 | "Freewheel" stop (factory setting)  |
|   | Controlled stop on torque ramp | Programmed between 0.5 and 60 s (for pump applications)   |
|   | Braked stop                    | Controlled dynamically by the flux  |

### Electromagnetic compatibility EMC (1)

|   | Standards  | Test levels   | Examples (sources of interference)             |
|---|--|---------------|--|
| Summary of immunity tests carried out with the Altistart 48 | <b>IEC 61000-4-2 level 3</b><br>Electrostatic discharge:<br>- by contact<br>- in the air   | 6 kV<br>8 kV  | Contact off an electrically charged individual |
|   | <b>IEC 61000-4-3 level 3</b><br>Radiated electromagnetic fields  | 10 V/m        | Equipment transmitting radio frequencies       |
|   | <b>IEC 61000-4-4 level 4</b><br>Rapid electrical transients:<br>- power supply cables<br>- control cables  | 4 kV<br>2 kV  | Opening/closing of a contactor                 |
|   | <b>IEC 61000-4-5 level 3</b><br>Shock wave:<br>- phase/phase<br>- phase/earth  | 1 kV<br>2 kV  | -  |
|   | <b>IEC 61000-4-12 level 3</b><br>Damped oscillating waves  | 1 kV - 1 M Hz | Oscillating circuit on the line supply         |
| Radiated and conducted emissions                            | According to IEC 60947-4-2, class A, on all starters<br>According to IEC 60947-4-2, class B, on starters up to 170 A: ATS 48D17● to 48C17●.<br>Must be bypassed at the end of starting |               |  |

(1) The starters conform to product standard IEC 60947-4-2, in particular with regard to EMC. This standard ensures a level of immunity for products and a level of emitted interference. In steady state, the interference emitted is below that required by the standard. During acceleration and deceleration phases, low level loads may be affected by low frequency interference (harmonics). To reduce this interference, connect chokes between the line supply and the Altistart 48 (see page 60528/3).

Note:

- Power factor correction capacitors can only be used upstream of the Altistart and only powered up at the end of starting.
- The starter must be earthed to conform to the regulations concerning leakage currents (≤ 30 mA). When the use of an upstream "residual current device" for protection is required by the installation standards, an A-Si type device must be used. Check its compatibility with the other protective devices. If the installation involves several starters on the same line supply, each starter must be earthed separately.

### Torque characteristics

Curves indicating changes in the torque depending on the starting current of a three-phase asynchronous motor.

Curves 1: direct line starting

Curves 2: starting in current limiting mode

Torque curve  $T_{s1}$  indicates the total torque range available depending on the limiting current  $I_{s1}$ .

Limiting the starting current  $I_s$  to a preset value  $I_{s1}$  will reduce the starting torque  $T_{s1}$  to a value which is almost equal to the square of currents  $I_{s1}/I_s$ .

Example:

For motor characteristics:  $T_s = 3 T_n$  for  $I_s = 6 I_n$ ,

limit the current to  $I_{s1} = 3 I_n$  ( $0.5 I_s$ )

resulting in a starting torque  $T_{s1} = T_s \times (0.5)^2 = 3 T_n \times 0.25 = 0.75 T_n$

### Starting current

- 1 Direct line starting current
- 2 Starting current limited to  $I_{s1}$

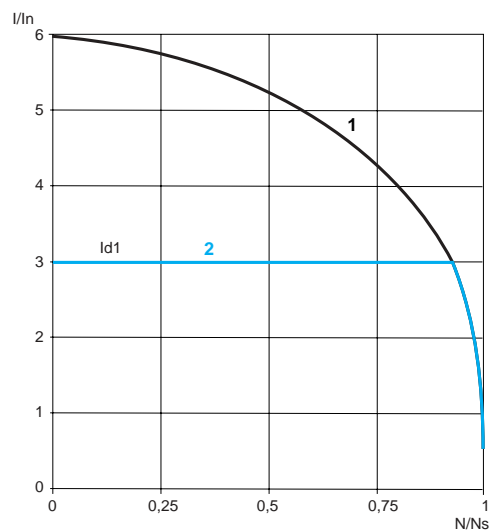

### Starting torque

- 1 Direct line starting torque
- 2 Starting torque with current limited to  $I_{s1}$

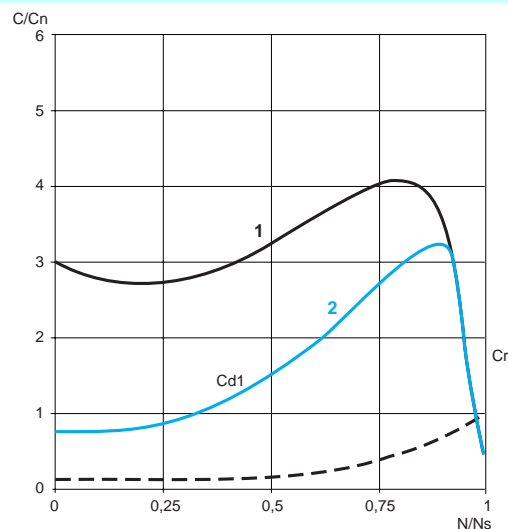

### Conventional starting using current limitation or voltage ramp

With current limitation  $I_{s1}$ , the accelerating torque applied to the motor is equal to the motor torque  $T_{s1}$  minus the resistive torque  $T_r$ .

The accelerating torque increases in the starting range as the speed changes and is at its highest at the end of acceleration (curve 2).

This characteristic means that the load is taken up very abruptly, which is not recommended for pump type applications.

Example of speed curve for starting with current limitation

- 1 Current applied to the motor ( $I/I_n$ )
- 2 Motor speed  $N/N_s$

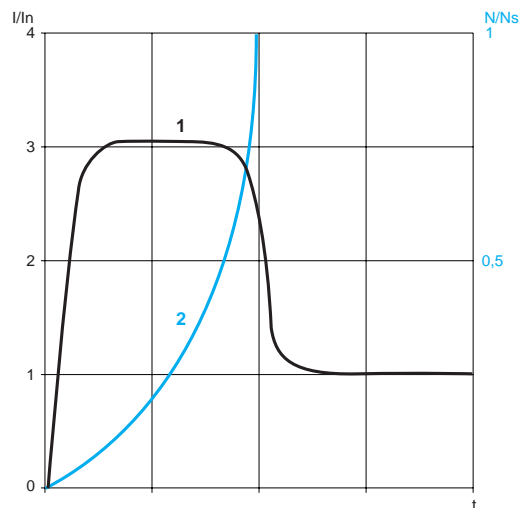

### Starting with the Altistart 48

Torque control on the Altistart 48 applies the torque to the motor during the entire starting phase if the current required (curve 1) does not exceed the limiting current. The accelerating torque can be virtually constant over the entire speed range (curve 2).

It is possible to set the Altistart in order to obtain a high torque on starting for a rapid motor speed rise whilst limiting its temperature rise, and a lower accelerating torque at the end of starting for gradual loading.

This control function is ideal for centrifugal pumps or for machines with high resistive torque on starting.

Example of speed curve for starting with torque control

- 1 Current applied to the motor ( $I/I_n$ )
- 2 Motor speed  $N/N_s$

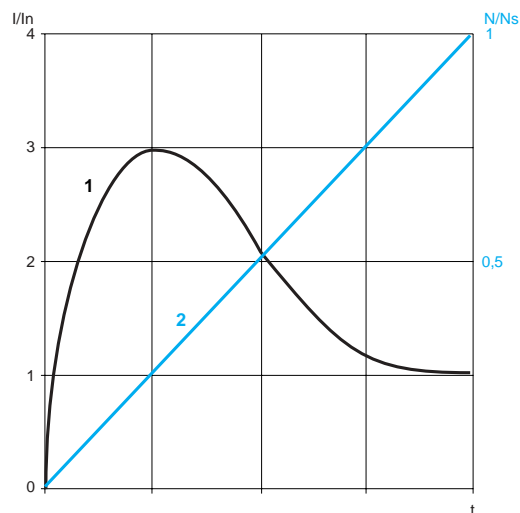

### Stopping with the Altistart 48

- Freewheel stop: the motor comes to a freewheel stop.
- Decelerated stop: this type of stop is ideal for pumps and can be used to effectively reduce pressure surges. Torque control on the Altistart 48 reduces the effect of hydraulic transients even if the load increases. This type of control makes adjustment easy.
- Braked stop: this type of stop is suitable for high inertia applications as it reduces the stopping time of the machine.

# Soft starters

## Altistart 48 soft start - soft stop units

### Selection criteria for an Altistart 48 soft start - soft stop unit

The Altistart 48 must be selected on the basis of 3 main criteria:

- Two line power supply voltage ranges are available for selection:
  - Three-phase a.c. voltage: 230 - 415 V
  - Three-phase a.c. voltage: 208 - 690 V
- The power and the nominal current indicated on the motor name plate
- The type of application and the operating cycle:  
To simplify selection, the applications are categorised into 2 types:
  - Standard applications
  - Severe applicationsStandard or severe applications define the limiting values of the current and the cycle for motor duties S1 and S4.

### Standard application

In standard applications, the Altistart 48 is designed to provide:

- Starting at 4 In for 23 seconds or at 3 In for 46 seconds from a cold state (corresponding to motor duty S1)
- Starting at 3 In for 23 seconds or at 4 In for 12 seconds with a load factor of 50% and 10 starts per hour or an equivalent thermal cycle (corresponding to motor duty S4)  
The motor thermal protection must conform to protection class 10 (see page 60526/4).  
Example: centrifugal pump

### Severe application

In severe applications, the Altistart 48 is designed to provide:

- Starting at 4 In for 48 seconds or at 3 In for 90 seconds from a cold state (corresponding to S1 motor duty)
- Starting at 4 In for 25 seconds with a load factor of 50% and 5 starts per hour or an equivalent thermal cycle (corresponding to S4 motor duty)  
The motor thermal protection must conform to protection class 20 (see page 60526/4).  
Example: grinder

### Motor duties

S1 motor duty corresponds to starting followed by operation at constant load enabling the thermal equilibrium to be reached.

S4 motor duty corresponds to a cycle comprising starting, operation at constant load and an idle period.

This cycle is characterised by a load factor of 50%.

### Selecting the starter

Once the appropriate application has been selected from the following page, select the starter from pages 60522/2 to 60522/5 according to the supply voltage and the motor power.

### Caution:

If the Altistart 48 is installed inside an enclosure, observe the mounting and derating recommendations (see page 60523/5).

## Soft starters

### Altistart 48 soft start - soft stop units

#### Application areas

Depending on the type of machine, the applications are categorized as standard or severe based on the starting characteristics, which are given as examples only, in the table below.

| Type of machine        | Application                  | Functions performed by the Altistart 48   | Starting current (% I <sub>n</sub> ) | Starting time (s) |
|------------------------|------------------------------|---|--------------------------------------|-------------------|
| Centrifugal pump       | Standard                     | Deceleration (reduction in pressure surges)<br>Protection against underloads or inversion of the phase rotation direction | 300                                  | 5 to 15           |
| Piston pump            | Standard                     | Control of running dry and direction of rotation of the pump  | 350                                  | 5 to 10           |
| Fan                    | Standard<br>Severe if > 30 s | Detection of overloads caused by clogging or underloads (motor fan transmission broken)<br>Braking torque on stopping     | 300                                  | 10 to 40          |
| Cold compressor        | Standard                     | Protection, even for special motors   | 300                                  | 5 to 10           |
| Screw compressor       | Standard                     | Protection against inversion of direction of phase rotation<br>Contact for automatic draining on stopping                 | 300                                  | 3 to 20           |
| Centrifugal compressor | Standard<br>Severe if > 30 s | Protection against inversion of direction of phase rotation<br>Contact for automatic emptying on stopping                 | 350                                  | 10 to 40          |
| Piston compressor      | Standard                     | Protection against inversion of direction of phase rotation<br>Contact for automatic emptying on stopping                 | 350                                  | 5 to 10           |
| Conveyor, transporter  | Standard                     | Overload control for detecting faults or underload control for detecting breaks   | 300                                  | 3 to 10           |
| Lifting screw          | Standard                     | Overload control for detecting hard spots or underload control for detecting breaks                                       | 300                                  | 3 to 10           |
| Drag lift              | Standard                     | Overload control for detecting jamming or underload control for detecting breaks  | 400                                  | 2 to 10           |
| Lift                   | Standard                     | Overload control for detecting jamming or underload control for detecting breaks<br>Constant starting with variable load  | 350                                  | 5 to 10           |
| Circular saw, band saw | Standard<br>Severe if > 30 s | Braking for fast stop   | 300                                  | 10 to 60          |
| Pulper, butchery knife | Severe                       | Torque control on starting  | 400                                  | 3 to 10           |
| Agitator               | Standard                     | The current display indicates the density of the product  | 350                                  | 5 to 20           |
| Mixer                  | Standard                     | The current display indicates the density of the product  | 350                                  | 5 to 10           |
| Grinder                | Severe                       | Braking to limit vibrations during stopping, overload control to detect jamming   | 450                                  | 5 to 60           |
| Crusher                | Severe                       | Braking to limit vibrations during stopping, overload control to detect jamming   | 400                                  | 10 to 40          |
| Refiner                | Standard                     | Torque control on starting and stopping   | 300                                  | 5 to 30           |
| Press                  | Severe                       | Braking to increase the number of cycles  | 400                                  | 20 to 60          |

### Special uses

Other criteria can influence the selection of the Altistart 48:

#### Starter wired to the motor delta terminal

(see the recommended application diagram on page 60524/4)

In addition to the most frequently encountered wiring layouts, where the starter is installed in the line supply of the motor and the motor is connected in star or delta configuration, the Altistart 48 ATS48\*\*\*Q can be wired to the motor delta terminal in series with each winding (see the application diagram below). The starter current is lower than the line current absorbed by the motor by a ratio of  $\sqrt{3}$ . This type of installation enables a starter with a lower rating to be used.

Example: For a 400 V/110 kW motor with a line current of 195 A (nominal current for the delta connection), the current in each winding is equal to  $195/\sqrt{3}$ , i.e. 114 A. Select the starter rating with a maximum permanent nominal current just above this current, i.e. 140A (ATS48C14Q for a standard application).

To avoid making this calculation, simply use the table on page 60522/3.

This type of installation only permits freewheel stopping and is not compatible with the cascade and preheating functions.

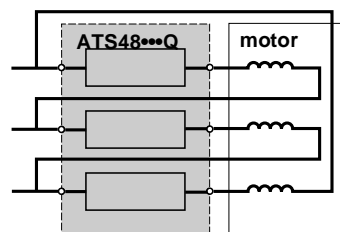

Starter wired in series with the motor windings

**Note:** The nominal current and limiting current settings as well as the current displayed during operation are on-line values (so do not have to be calculated by the user).

**Caution:** For this type of installation, observe the wiring scheme and the associated recommendations on page 60524/4.

#### Starter bypassed by a contactor

(see the recommended application diagram on page 60524/3)

The starter can be bypassed by a contactor at the end of starting (to limit the heat dissipated by the starter). The bypass contactor is controlled by the starter and the current measurements and protective mechanisms remain active when the starter is bypassed.

The starter is selected on the basis of the 3 main criteria and one of the following criteria:

- If the starter is bypassed at the end of starting, the motor is always started from cold state and the starter can be oversized by one rating.  
Example: Select an ATS 48D17Q for an 11 kW motor in a standard 400 V application.

- If the starter must be able to operate without the bypass contactor at the end of starting, it does not have to be derated.  
Example: Select an ATS 48D17Q for a 7.5 kW motor in a standard 400 V application.

#### Special uses (continued)

##### Motors in parallel

Motors may be connected in parallel provided that the power limit of the starter is not exceeded (the sum of the motor currents must not exceed the nominal current of the starter selected depending on the type of application). Provide thermal protection for each motor.

##### Brush motor

The Altistart 48 can operate with a bypassed rotor resistance motor or with a resistance lug. The starting torque is modified in accordance with the rotor resistance. If necessary, maintain a low resistance in order to obtain the required torque to overcome the resistive torque on starting.

A bypassed brush motor has a very low starting torque. A high stator current is required to obtain the sufficient starting torque.

Oversize the starter in order that the value of the limiting current is 7 times that of the nominal current.

**Note:** Ensure that the starting torque of the motor, equal to 7 times the nominal current, is greater than the resistive torque.

**Note:** The Altistart 48 torque control enables excellent soft starting despite the limiting current being 7 times the nominal current required to start the motor.

##### Dahlander motor and 2-speed motor

The Altistart 48 can operate with a 2-speed motor. A motor demagnetisation period must elapse before changing from low speed to high speed in order to avoid antiphases between the line supply and the motor, which would generate very high currents.

Select the starter using the 3 main criteria.

##### Very long cable

Very long motor cables cause voltage drops due to the resistance of the cable. If the voltage drop is significant, it could affect the current consumption and the torque available. This must therefore be taken into account when selecting the motor and the starter.

##### Starters in parallel on the same line supply

If several starters are installed on the same line supply, line chokes should be installed between the transformer and the starter (see page 60528/3).

##### Recommendations for use

**Caution:** Do not use the Altistart 48 upstream of loads other than motors (for example transformers and resistors are forbidden).

Do not connect power factor correction capacitors to the terminals of a motor controlled by an Altistart 48.

## Soft starters

Altistart 48 soft start - soft stop units

Line voltage 230/415 V

Connection in the motor supply line



ATS 48D17Q



ATS 48C14Q



ATS 48M12Q

### For standard applications

| Motor              |       | Starter 230/415 V - 50/60 Hz                    |                                      |   |            |         |
|--------------------|-------|---|--------------------------------------|---|------------|---------|
| Motor power<br>(1) |       | Nominal<br>current<br>(l <sub>CL</sub> )<br>(2) | Factory<br>setting<br>current<br>(4) | Power<br>dissipated<br>at nominal<br>load | Reference  | Weight  |
| 230 V              | 400 V | A   | A                                    | W   |            | kg      |
| kW                 | kW    |   |                                      |   |            |         |
| 4                  | 7.5   | 17  | 14.8                                 | 59  | ATS 48D17Q | 4.900   |
| 5.5                | 11    | 22  | 21                                   | 74  | ATS 48D22Q | 4.900   |
| 7.5                | 15    | 32  | 28.5                                 | 104                                       | ATS 48D32Q | 4.900   |
| 9                  | 18.5  | 38  | 35                                   | 116                                       | ATS 48D38Q | 4.900   |
| 11                 | 22    | 47  | 42                                   | 142                                       | ATS 48D47Q | 4.900   |
| 15                 | 30    | 62  | 57                                   | 201                                       | ATS 48D62Q | 8.300   |
| 18.5               | 37    | 75  | 69                                   | 245                                       | ATS 48D75Q | 8.300   |
| 22                 | 45    | 88  | 81                                   | 290                                       | ATS 48D88Q | 8.300   |
| 30                 | 55    | 110   | 100                                  | 322                                       | ATS 48C11Q | 8.300   |
| 37                 | 75    | 140   | 131                                  | 391                                       | ATS 48C14Q | 12.400  |
| 45                 | 90    | 170   | 162                                  | 479                                       | ATS 48C17Q | 12.400  |
| 55                 | 110   | 210   | 195                                  | 580                                       | ATS 48C21Q | 18.200  |
| 75                 | 132   | 250   | 233                                  | 695                                       | ATS 48C25Q | 18.200  |
| 90                 | 160   | 320   | 285                                  | 902                                       | ATS 48C32Q | 18.200  |
| 110                | 220   | 410   | 388                                  | 1339                                      | ATS 48C41Q | 51.400  |
| 132                | 250   | 480   | 437                                  | 1386                                      | ATS 48C48Q | 51.400  |
| 160                | 315   | 590   | 560                                  | 1731                                      | ATS 48C59Q | 51.400  |
| –                  | 355   | 660   | 605                                  | 1958                                      | ATS 48C66Q | 51.400  |
| 220                | 400   | 790   | 675                                  | 2537                                      | ATS 48C79Q | 115.000 |
| 250                | 500   | 1000  | 855                                  | 2865                                      | ATS 48M10Q | 115.000 |
| 355                | 630   | 1200  | 1045                                 | 3497                                      | ATS 48M12Q | 115.000 |

### For severe applications

| Motor              |       | Starter 230/415 V - 50/60 Hz |                                      |   |            |         |
|--------------------|-------|------------------------------|--------------------------------------|---|------------|---------|
| Motor power<br>(1) |       | Nominal<br>current<br>(3)    | Factory<br>setting<br>current<br>(4) | Power<br>dissipated<br>at nominal<br>load | Reference  | Weight  |
| 230 V              | 400 V | A                            | A                                    | W   |            | kg      |
| kW                 | kW    |                              |                                      |   |            |         |
| 3                  | 5.5   | 12                           | 14.8                                 | 46  | ATS 48D17Q | 4.900   |
| 4                  | 7.5   | 17                           | 21                                   | 59  | ATS 48D22Q | 4.900   |
| 5.5                | 11    | 22                           | 28.5                                 | 74  | ATS 48D32Q | 4.900   |
| 7.5                | 15    | 32                           | 35                                   | 99  | ATS 48D38Q | 4.900   |
| 9                  | 18.5  | 38                           | 42                                   | 116                                       | ATS 48D47Q | 4.900   |
| 11                 | 22    | 47                           | 57                                   | 153                                       | ATS 48D62Q | 8.300   |
| 15                 | 30    | 62                           | 69                                   | 201                                       | ATS 48D75Q | 8.300   |
| 18.5               | 37    | 75                           | 81                                   | 245                                       | ATS 48D88Q | 8.300   |
| 22                 | 45    | 88                           | 100                                  | 252                                       | ATS 48C11Q | 8.300   |
| 30                 | 55    | 110                          | 131                                  | 306                                       | ATS 48C14Q | 12.400  |
| 37                 | 75    | 140                          | 162                                  | 391                                       | ATS 48C17Q | 12.400  |
| 45                 | 90    | 170                          | 195                                  | 468                                       | ATS 48C21Q | 18.200  |
| 55                 | 110   | 210                          | 233                                  | 580                                       | ATS 48C25Q | 18.200  |
| 75                 | 132   | 250                          | 285                                  | 695                                       | ATS 48C32Q | 18.200  |
| 90                 | 160   | 320                          | 388                                  | 1017                                      | ATS 48C41Q | 51.400  |
| 110                | 220   | 410                          | 437                                  | 1172                                      | ATS 48C48Q | 51.400  |
| 132                | 250   | 480                          | 560                                  | 1386                                      | ATS 48C59Q | 51.400  |
| 160                | 315   | 590                          | 605                                  | 1731                                      | ATS 48C66Q | 51.400  |
| –                  | 355   | 660                          | 675                                  | 2073                                      | ATS 48C79Q | 115.000 |
| 220                | 400   | 790                          | 855                                  | 2225                                      | ATS 48M10Q | 115.000 |
| 250                | 500   | 1000                         | 1045                                 | 2865                                      | ATS 48M12Q | 115.000 |

(1) Value indicated on the motor rating plate

(2) Corresponds to the maximum permanent current in class 10. I<sub>CL</sub> corresponds to the starter rating.

(3) Corresponds to the maximum permanent current in class 20.

(4) The factory setting current corresponds to the value of the nominal current of a standard 4-pole, 400 V, class 10 motor (standard application). Adjust the settings in accordance with the motor nominal current.

## Soft starters

Altistart 48 soft start - soft stop units

Line voltage 230/415 V

Connection to the motor delta terminals

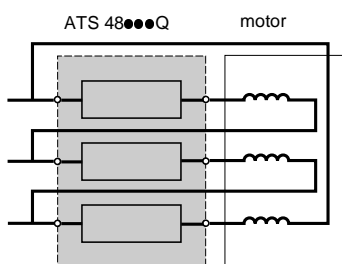

Figure 1

**Special use:**

Starter connected to the motor delta terminal in series with each winding

## For standard applications according to Figure 1

| Motor              |       | Starter 230/415 V - 50/60 Hz |                           |                                      |   |           |        |
|--------------------|-------|------------------------------|---------------------------|--------------------------------------|---|-----------|--------|
| Motor power<br>(1) |       |                              | Nominal<br>current<br>(2) | Factory<br>setting<br>current<br>(4) | Power<br>dissipated<br>at nominal<br>load | Reference | Weight |
|                    | 230 V | 400 V                        |                           |                                      |   |           |        |
| 7.5                | 15    | 29                           | 14.8                      | 59                                   | ATS 48D17Q                                | 4.900     |        |
| 9                  | 18.5  | 38                           | 21                        | 74                                   | ATS 48D22Q                                | 4.900     |        |
| 15                 | 22    | 55                           | 28.5                      | 104                                  | ATS 48D32Q                                | 4.900     |        |
| 18.5               | 30    | 66                           | 35                        | 116                                  | ATS 48D38Q                                | 4.900     |        |
| 22                 | 45    | 81                           | 42                        | 142                                  | ATS 48D47Q                                | 4.900     |        |
| 30                 | 55    | 107                          | 57                        | 201                                  | ATS 48D62Q                                | 8.300     |        |
| 37                 | 55    | 130                          | 69                        | 245                                  | ATS 48D75Q                                | 8.300     |        |
| 45                 | 75    | 152                          | 81                        | 290                                  | ATS 48D88Q                                | 8.300     |        |
| 55                 | 90    | 191                          | 100                       | 322                                  | ATS 48C11Q                                | 8.300     |        |
| 75                 | 110   | 242                          | 131                       | 391                                  | ATS 48C14Q                                | 12.400    |        |
| 90                 | 132   | 294                          | 162                       | 479                                  | ATS 48C17Q                                | 12.400    |        |
| 110                | 160   | 364                          | 195                       | 580                                  | ATS 48C21Q                                | 18.200    |        |
| 132                | 220   | 433                          | 233                       | 695                                  | ATS 48C25Q                                | 18.200    |        |
| 160                | 250   | 554                          | 285                       | 902                                  | ATS 48C32Q                                | 18.200    |        |
| 220                | 315   | 710                          | 388                       | 1339                                 | ATS 48C41Q                                | 51.400    |        |
| 250                | 355   | 831                          | 437                       | 1386                                 | ATS 48C48Q                                | 51.400    |        |
| -                  | 400   | 1022                         | 560                       | 1731                                 | ATS 48C59Q                                | 51.400    |        |
| 315                | 500   | 1143                         | 605                       | 1958                                 | ATS 48C66Q                                | 51.400    |        |
| 355                | 630   | 1368                         | 675                       | 2537                                 | ATS 48C79Q                                | 115.000   |        |
| -                  | 710   | 1732                         | 855                       | 2865                                 | ATS 48M10Q                                | 115.000   |        |
| 500                | -     | 2078                         | 1045                      | 3497                                 | ATS 48M12Q                                | 115.000   |        |

## For severe applications according to Figure 1

| Motor              |       | Starter 230/415 V - 50/60 Hz |                           |                                      |   |           |        |
|--------------------|-------|------------------------------|---------------------------|--------------------------------------|---|-----------|--------|
| Motor power<br>(1) |       |                              | Nominal<br>current<br>(3) | Factory<br>setting<br>current<br>(4) | Power<br>dissipated<br>at nominal<br>load | Reference | Weight |
|                    | 230 V | 400 V                        |                           |                                      |   |           |        |
| 5.5                | 11    | 22                           | 14.8                      | 46                                   | ATS 48D17Q                                | 4.900     |        |
| 7.5                | 15    | 29                           | 21                        | 59                                   | ATS 48D22Q                                | 4.900     |        |
| 9                  | 18.5  | 38                           | 28.5                      | 74                                   | ATS 48D32Q                                | 4.900     |        |
| 15                 | 22    | 55                           | 35                        | 99                                   | ATS 48D38Q                                | 4.900     |        |
| 18.5               | 30    | 66                           | 42                        | 116                                  | ATS 48D47Q                                | 4.900     |        |
| 22                 | 45    | 81                           | 57                        | 153                                  | ATS 48D62Q                                | 8.300     |        |
| 30                 | 55    | 107                          | 69                        | 201                                  | ATS 48D75Q                                | 8.300     |        |
| 37                 | 55    | 130                          | 81                        | 245                                  | ATS 48D88Q                                | 8.300     |        |
| 45                 | 75    | 152                          | 100                       | 252                                  | ATS 48C11Q                                | 8.300     |        |
| 55                 | 90    | 191                          | 131                       | 306                                  | ATS 48C14Q                                | 12.400    |        |
| 75                 | 110   | 242                          | 162                       | 391                                  | ATS 48C17Q                                | 12.400    |        |
| 90                 | 132   | 294                          | 195                       | 468                                  | ATS 48C21Q                                | 18.200    |        |
| 110                | 160   | 364                          | 233                       | 580                                  | ATS 48C25Q                                | 18.200    |        |
| 132                | 220   | 433                          | 285                       | 695                                  | ATS 48C32Q                                | 18.200    |        |
| 160                | 250   | 554                          | 388                       | 1017                                 | ATS 48C41Q                                | 51.400    |        |
| 220                | 315   | 710                          | 437                       | 1172                                 | ATS 48C48Q                                | 51.400    |        |
| 250                | 355   | 831                          | 560                       | 1386                                 | ATS 48C59Q                                | 51.400    |        |
| -                  | 400   | 1022                         | 605                       | 1731                                 | ATS 48C66Q                                | 51.400    |        |
| 315                | 500   | 1143                         | 675                       | 2073                                 | ATS 48C79Q                                | 115.000   |        |
| 355                | 630   | 1368                         | 855                       | 2225                                 | ATS 48M10Q                                | 115.000   |        |
| -                  | 710   | 1732                         | 1045                      | 2865                                 | ATS 48M12Q                                | 115.000   |        |

(1) Value indicated on the motor rating plate

(2) Corresponds to the maximum permanent current in class 10.

(3) Corresponds to the maximum permanent current in class 20.

(4) For this type of connection, the factory setting current must be adjusted in accordance with the nominal motor current.

## Soft starters

Altistart 48 soft start - soft stop units

Line voltage 208/690 V

Motor power in HP



ATS 48D17Y



ATS 48C14Y



ATS 48M12Y

### For standard applications

| Motor           |       |       |       |      | Starter 208/690 V - 50/60 Hz |                             |                                  |           |        |
|-----------------|-------|-------|-------|------|------------------------------|-----------------------------|----------------------------------|-----------|--------|
| Motor power (1) |       |       |       |      | Nominal current (IcL) (2)    | Factory setting current (4) | Power dissipated at nominal load | Reference | Weight |
| 208 V           | 230 V | 460 V | 575 V | A    |                              |                             |                                  |           |        |
| HP              | HP    | HP    | HP    |      |                              |                             |                                  |           |        |
| 3               | 5     | 10    | 15    | 17   | 14                           | 59                          | ATS 48D17Y                       | 4.900     |        |
| 5               | 7.5   | 15    | 20    | 22   | 21                           | 74                          | ATS 48D22Y                       | 4.900     |        |
| 7.5             | 10    | 20    | 25    | 32   | 27                           | 104                         | ATS 48D32Y                       | 4.900     |        |
| 10              | -     | 25    | 30    | 38   | 34                           | 116                         | ATS 48D38Y                       | 4.900     |        |
| -               | 15    | 30    | 40    | 47   | 40                           | 142                         | ATS 48D47Y                       | 4.900     |        |
| 15              | 20    | 40    | 50    | 62   | 52                           | 201                         | ATS 48D62Y                       | 8.300     |        |
| 20              | 25    | 50    | 60    | 75   | 65                           | 245                         | ATS 48D75Y                       | 8.300     |        |
| 25              | 30    | 60    | 75    | 88   | 77                           | 290                         | ATS 48D88Y                       | 8.300     |        |
| 30              | 40    | 75    | 100   | 110  | 96                           | 322                         | ATS 48C11Y                       | 8.300     |        |
| 40              | 50    | 100   | 125   | 140  | 124                          | 391                         | ATS 48C14Y                       | 12.400    |        |
| 50              | 60    | 125   | 150   | 170  | 156                          | 479                         | ATS 48C17Y                       | 12.400    |        |
| 60              | 75    | 150   | 200   | 210  | 180                          | 580                         | ATS 48C21Y                       | 18.200    |        |
| 75              | 100   | 200   | 250   | 250  | 240                          | 695                         | ATS 48C25Y                       | 18.200    |        |
| 100             | 125   | 250   | 300   | 320  | 302                          | 902                         | ATS 48C32Y                       | 18.200    |        |
| 125             | 150   | 300   | 350   | 410  | 361                          | 1339                        | ATS 48C41Y                       | 51.400    |        |
| 150             | -     | 350   | 400   | 480  | 414                          | 1386                        | ATS 48C48Y                       | 51.400    |        |
| -               | 200   | 400   | 500   | 590  | 477                          | 1731                        | ATS 48C59Y                       | 51.400    |        |
| 200             | 250   | 500   | 600   | 660  | 590                          | 1958                        | ATS 48C66Y                       | 51.400    |        |
| 250             | 300   | 600   | 800   | 790  | 720                          | 2537                        | ATS 48C79Y                       | 115.000   |        |
| 350             | 350   | 800   | 1000  | 1000 | 954                          | 2865                        | ATS 48M10Y                       | 115.000   |        |
| 400             | 450   | 1000  | 1200  | 1200 | 1170                         | 3497                        | ATS 48M12Y                       | 115.000   |        |

### For severe applications

| Motor           |       |       |       |      | Starter 208/690 V - 50/60 Hz |                             |                                  |           |        |
|-----------------|-------|-------|-------|------|------------------------------|-----------------------------|----------------------------------|-----------|--------|
| Motor power (1) |       |       |       |      | Nominal current (3)          | Factory setting current (4) | Power dissipated at nominal load | Reference | Weight |
| 208 V           | 230 V | 460 V | 575 V | A    |                              |                             |                                  |           |        |
| HP              | HP    | HP    | HP    |      |                              |                             |                                  |           |        |
| 2               | 3     | 7.5   | 10    | 12   | 14                           | 46                          | ATS 48D17Y                       | 4.900     |        |
| 3               | 5     | 10    | 15    | 17   | 21                           | 59                          | ATS 48D22Y                       | 4.900     |        |
| 5               | 7.5   | 15    | 20    | 22   | 27                           | 74                          | ATS 48D32Y                       | 4.900     |        |
| 7.5             | 10    | 20    | 25    | 32   | 34                           | 99                          | ATS 48D38Y                       | 4.900     |        |
| 10              | -     | 25    | 30    | 38   | 40                           | 116                         | ATS 48D47Y                       | 4.900     |        |
| -               | 15    | 30    | 40    | 47   | 52                           | 153                         | ATS 48D62Y                       | 8.300     |        |
| 15              | 20    | 40    | 50    | 62   | 65                           | 201                         | ATS 48D75Y                       | 8.300     |        |
| 20              | 25    | 50    | 60    | 75   | 77                           | 245                         | ATS 48D88Y                       | 8.300     |        |
| 25              | 30    | 60    | 75    | 88   | 96                           | 252                         | ATS 48C11Y                       | 8.300     |        |
| 30              | 40    | 75    | 100   | 110  | 124                          | 306                         | ATS 48C14Y                       | 12.400    |        |
| 40              | 50    | 100   | 125   | 140  | 156                          | 391                         | ATS 48C17Y                       | 12.400    |        |
| 50              | 60    | 125   | 150   | 170  | 180                          | 468                         | ATS 48C21Y                       | 18.200    |        |
| 60              | 75    | 150   | 200   | 210  | 240                          | 580                         | ATS 48C25Y                       | 18.200    |        |
| 75              | 100   | 200   | 250   | 250  | 302                          | 695                         | ATS 48C32Y                       | 18.200    |        |
| 100             | 125   | 250   | 300   | 320  | 361                          | 1017                        | ATS 48C41Y                       | 51.400    |        |
| 125             | 150   | 300   | 350   | 410  | 414                          | 1172                        | ATS 48C48Y                       | 51.400    |        |
| 150             | -     | 350   | 400   | 480  | 477                          | 1386                        | ATS 48C59Y                       | 51.400    |        |
| -               | 200   | 400   | 500   | 590  | 590                          | 1731                        | ATS 48C66Y                       | 51.400    |        |
| 200             | 250   | 500   | 600   | 660  | 720                          | 2073                        | ATS 48C79Y                       | 115.000   |        |
| 250             | 300   | 600   | 800   | 790  | 954                          | 2225                        | ATS 48M10Y                       | 115.000   |        |
| 350             | 350   | 800   | 1000  | 1000 | 1170                         | 2865                        | ATS 48M12Y                       | 115.000   |        |

(1) Value indicated on the motor rating plate

(2) Corresponds to the maximum permanent current in class 10. I<sub>cL</sub> corresponds to the starter rating.

(3) Corresponds to the maximum permanent current in class 20.

(4) The factory setting current corresponds to the value of the nominal current of a standard motor according to NEC, 460 V, class 10 (standard application). Adjust the settings in accordance with the motor nominal current.

## Soft starters

Altistart 48 soft start - soft stop units

Line voltage 208/690 V

Motor power in kW

## For standard applications

| Motor           |       |       |       |       |       |       | Starter 208/690 V - 50/60 Hz |                             |                                  |            |         |
|-----------------|-------|-------|-------|-------|-------|-------|------------------------------|-----------------------------|----------------------------------|------------|---------|
| Motor power (1) |       |       |       |       |       |       | Nominal current (IcL) (2)    | Factory setting current (4) | Power dissipated at nominal load | Reference  | Weight  |
| 230 V           | 400 V | 440 V | 500 V | 525 V | 660 V | 690 V |                              |                             |                                  |            |         |
| kW              | kW    | kW    | kW    | kW    | kW    | kW    |                              |                             |                                  |            |         |
| 4               | 7.5   | 7.5   | 9     | 9     | 11    | 15    | 17                           | 14                          | 59                               | ATS 48D17Y | 4.900   |
| 5.5             | 11    | 11    | 11    | 11    | 15    | 18.5  | 22                           | 21                          | 74                               | ATS 48D22Y | 4.900   |
| 7.5             | 15    | 15    | 18.5  | 18.5  | 22    | 22    | 32                           | 27                          | 104                              | ATS 48D32Y | 4.900   |
| 9               | 18.5  | 18.5  | 22    | 22    | 30    | 30    | 38                           | 34                          | 116                              | ATS 48D38Y | 4.900   |
| 11              | 22    | 22    | 30    | 30    | 37    | 37    | 47                           | 40                          | 142                              | ATS 48D47Y | 4.900   |
| 15              | 30    | 30    | 37    | 37    | 45    | 45    | 62                           | 52                          | 201                              | ATS 48D62Y | 8.300   |
| 18.5            | 37    | 37    | 45    | 45    | 55    | 55    | 75                           | 65                          | 245                              | ATS 48D75Y | 8.300   |
| 22              | 45    | 45    | 55    | 55    | 75    | 75    | 88                           | 77                          | 290                              | ATS 48D88Y | 8.300   |
| 30              | 55    | 55    | 75    | 75    | 90    | 90    | 110                          | 96                          | 322                              | ATS 48C11Y | 8.300   |
| 37              | 75    | 75    | 90    | 90    | 110   | 110   | 140                          | 124                         | 391                              | ATS 48C14Y | 12.400  |
| 45              | 90    | 90    | 110   | 110   | 132   | 160   | 170                          | 156                         | 479                              | ATS 48C17Y | 12.400  |
| 55              | 110   | 110   | 132   | 132   | 160   | 200   | 210                          | 180                         | 580                              | ATS 48C21Y | 18.200  |
| 75              | 132   | 132   | 160   | 160   | 220   | 250   | 250                          | 240                         | 695                              | ATS 48C25Y | 18.200  |
| 90              | 160   | 160   | 220   | 220   | 250   | 315   | 320                          | 302                         | 902                              | ATS 48C32Y | 18.200  |
| 110             | 220   | 220   | 250   | 250   | 355   | 400   | 410                          | 361                         | 1339                             | ATS 48C41Y | 51.400  |
| 132             | 250   | 250   | 315   | 315   | 400   | 500   | 480                          | 414                         | 1386                             | ATS 48C48Y | 51.400  |
| 160             | 315   | 355   | 400   | 400   | 560   | 560   | 590                          | 477                         | 1731                             | ATS 48C59Y | 51.400  |
| –               | 355   | 400   | –     | –     | 630   | 630   | 660                          | 590                         | 1958                             | ATS 48C66Y | 51.400  |
| 220             | 400   | 500   | 500   | 500   | 710   | 710   | 790                          | 720                         | 2537                             | ATS 48C79Y | 115.000 |
| 250             | 500   | 630   | 630   | 630   | 900   | 900   | 1000                         | 954                         | 2865                             | ATS 48M10Y | 115.000 |
| 355             | 630   | 710   | 800   | 800   | –     | –     | 1200                         | 1170                        | 3497                             | ATS 48M12Y | 115.000 |

## For severe applications

| Motor           |       |       |       |       |       |       | Starter 208/690 V - 50/60 Hz |                             |                                  |            |         |
|-----------------|-------|-------|-------|-------|-------|-------|------------------------------|-----------------------------|----------------------------------|------------|---------|
| Motor power (1) |       |       |       |       |       |       | Nominal current (3)          | Factory setting current (4) | Power dissipated at nominal load | Reference  | Weight  |
| 230 V           | 400 V | 440 V | 500 V | 525 V | 660 V | 690 V |                              |                             |                                  |            |         |
| kW              | kW    | kW    | kW    | kW    | kW    | kW    |                              |                             |                                  |            |         |
| 3               | 5.5   | 5.5   | 7.5   | 7.5   | 9     | 11    | 12                           | 14                          | 46                               | ATS 48D17Y | 4.900   |
| 4               | 7.5   | 7.5   | 9     | 9     | 11    | 15    | 17                           | 21                          | 59                               | ATS 48D22Y | 4.900   |
| 5.5             | 11    | 11    | 11    | 11    | 15    | 18.5  | 22                           | 27                          | 74                               | ATS 48D32Y | 4.900   |
| 7.5             | 15    | 15    | 18.5  | 18.5  | 22    | 22    | 32                           | 34                          | 99                               | ATS 48D38Y | 4.900   |
| 9               | 18.5  | 18.5  | 22    | 22    | 30    | 30    | 38                           | 40                          | 116                              | ATS 48D47Y | 4.900   |
| 11              | 22    | 22    | 30    | 30    | 37    | 37    | 47                           | 52                          | 153                              | ATS 48D62Y | 8.300   |
| 15              | 30    | 30    | 37    | 37    | 45    | 45    | 62                           | 65                          | 201                              | ATS 48D75Y | 8.300   |
| 18.5            | 37    | 37    | 45    | 45    | 55    | 55    | 75                           | 77                          | 245                              | ATS 48D88Y | 8.300   |
| 22              | 45    | 45    | 55    | 55    | 75    | 75    | 88                           | 96                          | 252                              | ATS 48C11Y | 8.300   |
| 30              | 55    | 55    | 75    | 75    | 90    | 90    | 110                          | 124                         | 306                              | ATS 48C14Y | 12.400  |
| 37              | 75    | 75    | 90    | 90    | 110   | 110   | 140                          | 156                         | 391                              | ATS 48C17Y | 12.400  |
| 45              | 90    | 90    | 110   | 110   | 132   | 160   | 170                          | 180                         | 468                              | ATS 48C21Y | 18.200  |
| 55              | 110   | 110   | 132   | 132   | 160   | 200   | 210                          | 240                         | 580                              | ATS 48C25Y | 18.200  |
| 75              | 132   | 132   | 160   | 160   | 220   | 250   | 250                          | 302                         | 695                              | ATS 48C32Y | 18.200  |
| 90              | 160   | 160   | 220   | 220   | 250   | 315   | 320                          | 361                         | 1017                             | ATS 48C41Y | 51.400  |
| 110             | 220   | 220   | 250   | 250   | 355   | 400   | 410                          | 414                         | 1172                             | ATS 48C48Y | 51.400  |
| 132             | 250   | 250   | 315   | 315   | 400   | 500   | 480                          | 477                         | 1386                             | ATS 48C59Y | 51.400  |
| 160             | 315   | 355   | 400   | 400   | 560   | 560   | 590                          | 590                         | 1731                             | ATS 48C66Y | 51.400  |
| –               | 355   | 400   | –     | –     | 630   | 630   | 660                          | 720                         | 2073                             | ATS 48C79Y | 115.000 |
| 220             | 400   | 500   | 500   | 500   | 710   | 710   | 790                          | 954                         | 2225                             | ATS 48M10Y | 115.000 |
| 250             | 500   | 630   | 630   | 630   | 900   | 900   | 1000                         | 1170                        | 2865                             | ATS 48M12Y | 115.000 |

(1) Value indicated on the motor rating plate

(2) Corresponds to the maximum permanent current in class 10. I<sub>cL</sub> corresponds to the starter rating.

(3) Corresponds to the maximum permanent current in class 20.

(4) The factory setting current corresponds to the value of the nominal current of a standard motor according to NEC, 460 V, class 10 (standard application). Adjust the settings in accordance with the motor nominal current.

# Soft starters

## Altistart 48 soft start - soft stop units

Options: Communication modules

### Presentation

The Altistart 48 can be connected directly to the Modbus bus using an RJ45 connector and communicates using the RS 485 serial link (2-wire) and the Modbus RTU protocol. The communication function provides access to the configuration, adjustment, control and signalling functions of the starter.

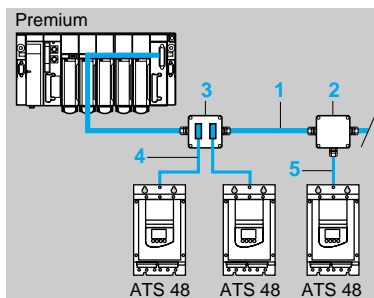

- 1 Modbus cable **TSX SCA 000**
- 2 Junction box **TSX SCA 50**
- 3 Subscriber sockets **TSX SCA 62**
- 4 Modbus drop cable **VW3 A8 306**
- 5 Modbus drop cable **VW3 A8 306 D30**

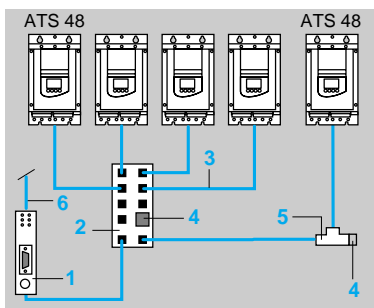

- 1 Communication module
- 2 Modbus hub **LU9 GC3**
- 3 Modbus drop cable **VW3 A8 306 R00**
- 4 Line terminator **VW3 A8 306 RC**
- 5 Modbus T-junction box **VW3 A8 306 TF3**
- 6 To other buses or networks

The Altistart 48 can be connected to other buses or networks using the communication modules and accessories below.

### References

| Communication modules   | Cables to be connected                                 | Reference  | Weight kg                    |
|---|--|--|------------------------------|
| <b>Ethernet/Modbus bridge</b><br>with 1 x Ethernet 10baseT port (RJ45 type) | To be connected using cable VW3 P10 306 R10            | <b>174 CEV 300 10</b>                              | 0.500                        |
| <b>FIPIO/Modbus gateway</b>   | To be connected using cables VW3 A8 306 R00            | <b>LUF P1 ▲</b>                                    | 0.240                        |
| <b>DeviceNet/Modbus gateway</b>   | To be connected using cables VW3 A8 306 R00            | <b>LUF P9 ▲</b>                                    | 0.240                        |
| <b>Profibus DP/Modbus gateway</b>   | To be connected using cable VW3 P07 306 R10            | <b>LA9 P307</b>                                    | 0.240                        |
| Connection accessories  | Connectors   | Reference  | Weight kg                    |
| <b>Junction box</b> (to be connected with cable VW3 A8 306 D30)             | 3 screw terminals                                      | <b>TSX SCA 50</b>                                  | 0.520                        |
| <b>2-channel subscriber sockets</b> (to be connected with cable VW3 A8 306) | 2 15-way female SUB-D connectors and 2 screw terminals | <b>TSX SCA 62</b>                                  | 0.570                        |
| <b>Modbus hub</b>   | 8 RJ45 connectors                                      | <b>LU9 GC3 ▲</b>                                   | 0.500                        |
| <b>Line terminator</b>  | –  | <b>VW3 A8 306 RC</b>                               | –                            |
| <b>Modbus T-junction box</b>  | –  | <b>VW3 A8 306 TF3</b>                              | –                            |
| Connecting cables   | Connectors   | Reference  | Weight kg                    |
| <b>For bus and networks</b>   |  |  |                              |
| <b>Modbus</b>   | 3  | 1 RJ45 connector and one end stripped              | <b>VW3 A8 306 D30</b> 0.150  |
|   | 3  | 1 RJ45 connector and 1 15-way male SUB-D connector | <b>VW3 A8 306</b> 0.150      |
| <b>FIPIO, DeviceNet</b>   | 0.3  | 2 RJ45 connectors                                  | <b>VW3 A8 306 R03</b> 0.050  |
| <b>Modbus</b>   | 1  | 2 RJ45 connectors                                  | <b>VW3 A8 306 R10</b> 0.050  |
|   | 3  | 2 RJ45 connectors                                  | <b>VW3 A8 306 R30</b> 0.150  |
| <b>Profibus DP</b>  | 1  | 2 RJ45 connectors                                  | <b>VW3 P07 306 R10</b> 0.050 |
| <b>Ethernet</b>   | 1  | 2 RJ45 connectors                                  | <b>VW3 P10 306 R10</b> 0.050 |

▲ To be launched 3rd quarter 2002.

822796



174 CEV 300 10

520876



LUF P1

## Soft starters

### Altistart 48 soft start - soft stop units

Options: Remote terminal, line chokes, protective covers, documentation



VW3 G48101

#### Remote terminal

The terminal can be mounted on the door of a wall-fixing or floor-standing enclosure. It has the same signalling display and configuration buttons as the terminal integrated in the starter. A switch to lock access to the menu is located at the rear of the terminal.

The option comprises:

- the remote terminal
- a mounting kit containing a cover, screws and an IP 54 seal on the front panel
- a 3 m connecting cable with a 9-way SUB-D connector for connecting to the terminal and an RJ45 connector for connecting to the Altistart 48

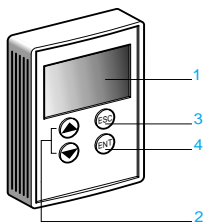

- 1 Information is displayed in the form of codes or values in three "7-segment" displays
- 2 Buttons for scrolling through the menus or modifying values
- 3 "ESC": Button for exiting the menus (cannot be used for validation purposes)
- 4 "ENT": Validation button for entering a menu or confirming the new value selected

#### Reference

| Description     | Reference  | Weight kg |
|-----------------|------------|-----------|
| Remote terminal | VW3 G48101 | 0.200     |

#### Line chokes

The use of line chokes is recommended in particular when installing several electronic starters on the same line supply. The values of the chokes are defined for a voltage drop between 3% and 5% of the nominal line voltage.

Install the line choke between the line contactor and the starter.

#### References

| For starters          | Value of the choke mH | Nominal current A | Degree of protection | Reference     | Weight kg |
|-----------------------|-----------------------|-------------------|----------------------|---------------|-----------|
| ATS 48D17●            | 1.7                   | 15                | IP 20                | VZ1 L015UM17T | 2.100     |
| ATS 48D22●            | 0.8                   | 30                | IP 20                | VZ1 L030U800T | 4.100     |
| ATS 48D32● and 48D38● | 0.6                   | 40                | IP 20                | VZ1 L040U600T | 5.100     |
| ATS 48D47● and 48D62● | 0.35                  | 70                | IP 20                | VZ1 L070U350T | 8.000     |
| ATS 48D75● to 48C14●  | 0.17                  | 150               | IP 00                | VZ1 L150U170T | 14.900    |
| ATS 48C17● to 48C25●  | 0.1                   | 250               | IP 00                | VZ1 L250U100T | 24.300    |
| ATS 48C32●            | 0.075                 | 325               | IP 00                | VZ1 L325U075T | 28.900    |
| ATS 48C41● and 48C48● | 0.045                 | 530               | IP 00                | VZ1 L530U045T | 37.000    |
| ATS 48C59● to 48M10●  | 0.024                 | 1025              | IP 00                | VZ1 LM10U024T | 66.000    |
| ATS 48M12●            | 0.016                 | 1435              | IP 00                | VZ1 LM14U016T | 80.000    |

**Note:** Line chokes with IP 00 degree of protection must be fitted with a protective bar to protect personnel against electrical contact.

#### Protective covers for power terminals

To be used with tags closed

#### References

| For starters                          | Number of covers per set | Reference | Weight kg |
|---------------------------------------|--------------------------|-----------|-----------|
| ATS 48C14● and ATS 48C17●             | 6 (1)                    | LA9 F702  | 0.250     |
| ATS 48C21●, ATS 48C25● and ATS 48C32● | 6 (1)                    | LA9 F703  | 0.250     |

(1) The starters have 9 unprotected power terminals.

**Note:**

#### Documentation

| Description  | Format | Reference     | Weight kg |
|--|--------|---------------|-----------|
| Altistart 48 user's manual                             | A5     | VVD ED 301066 | 0.150     |
| Modbus user's manual                                   | A5     | VVD ED 302023 | 0.150     |
| Ethernet, FIPIO, DeviceNet, Profibus DP user's manuals | CD-ROM | DCI CD 398111 | 0.150     |

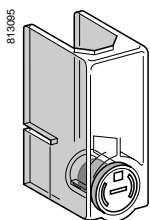

LA9 F702

# PowerSuite advanced dialogue solutions

The PowerSuite advanced dialogue solutions can be used for Schneider Electric drives and starters. They enable communication with the product from a Pocket PC, a PC or a dedicated terminal.

The solutions, with a Pocket PC or PC, enable files to be prepared for uploading to the drives and the starters. The PowerSuite software creates its files ensuring consistency between the configuration/adjustment functions of the product.

## PowerSuite Pocket PC

The Pocket PC can be used during preparation, programming, setup and maintenance.

It comprises a Pocket PC terminal and corresponding connection accessories. The software is integrated into a Windows CE environment, for which the operating system language can be selected on ordering (English, French, German, Spanish, Italian).

The software incorporates all the functions of integrated and remote terminals (drive or starter configuration and adjustment, control, signalling, etc.).

The Pocket PC can be used:

- alone to prepare and store configuration/adjustment files (integral battery or line supply)
- connected to a PC for uploading configuration/adjustment files from the Pocket PC to the PC or downloading from the PC to the Pocket PC
- connected to the drive or to the starter for configuration, adjustment or control purposes or to upload a configuration/adjustment file from the Pocket PC to the product or download a configuration/adjustment file from the product to the Pocket PC.

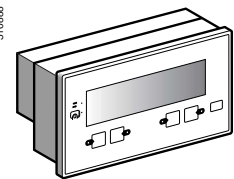
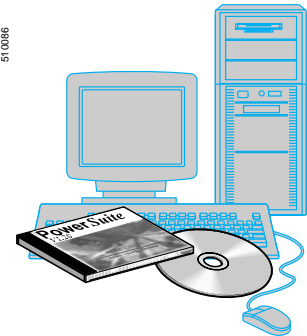
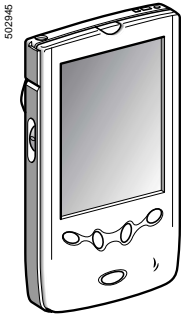

## PowerSuite software workshop for PC

The PowerSuite software workshop is used to set up a drive or a starter from a PC in a Microsoft Windows 95, 98, NT4 or 2000 environment.

The software incorporates all the functions of integrated and remote terminals (drive or starter configuration and adjustment, control, signalling, etc.) with assisted, guided operator dialogue in 5 languages (English, French, German, Spanish, Italian) in a Windows environment.

It can be used:

- alone to prepare and store drive or starter configuration files on diskette, CD-ROM or hard disk

The drive or starter configuration can be printed out on paper or can be exported to office automation software.

- connected to the drive or starter for configuration, adjustment or control purposes, or for uploading a configuration/adjustment file from the PC to the product or downloading from the product to the PC.

Connection is via a link between the drive or starter connector and the serial port on the PC.

## Magelis display unit with matrix screen

The Magelis display unit with matrix screen can be used to monitor, diagnose and adjust up to 8 Altivar 28, 38, 58 or 58F drives in 5 languages (English, French, German, Spanish, Italian). It can display variables in alphanumeric format with European, Cyrillic or Asian fonts in 4 sizes, or it can display icons or background images in black and white as well as animations in bargraph or gauge format. The application is preloaded in the factory.

## Compatibility

Compatibility of advanced dialogue solutions with drives and starters

|  |                | Drives                  |          |          | Starter  | TeSys model U controller-starters |
|--|----------------|-------------------------|----------|----------|----------|-----------------------------------|
|  |                | ATV 28, ATV 58, ATV 58F | ATV 38   | ATV 11   | ATS 48   |                                   |
| <b>PowerSuite Pocket PC</b>                    |                |                         |          |          |          |                                   |
| Pocket PC                                      | VW3 A8108●●    | ≥ V 1.20                | ≥ V 1.40 | ≥ V 1.40 | ≥ V 1.30 |                                   |
| Setup kit                                      | VW3 A8102      | ≥ V 1.20                | ≥ V 1.40 | ≥ V 1.40 | ≥ V 1.30 |                                   |
| Connection kit                                 | VW3 A8111      |                         |          |          |          |                                   |
| <b>PowerSuite software workshop for PC</b>     |                |                         |          |          |          |                                   |
| CD-ROM   | VW3 A8104▲     | ≥ V 1.0                 | ≥ V 1.40 | ≥ V 1.40 | ≥ V 1.30 | ≥ V 1.40                          |
| Connection kit                                 | VW3 A8106      |                         |          |          |          |                                   |
| <b>Magelis display unit with matrix screen</b> |                |                         |          |          |          |                                   |
| Display unit                                   | XBT HM017010A8 |                         |          |          |          |                                   |
| <b>Accessories</b>                             |                |                         |          |          |          |                                   |
| CD-ROM   | VW3 A8105▲     | ≥ V 1.0                 | ≥ V 1.40 | ≥ V 1.40 | ≥ V 1.30 | ≥ V 1.40                          |
| Operator terminal                              | VW3 A8103●●    |                         |          |          |          |                                   |

■ Incompatible products

■ Compatible products and versions

▲ V 1.40 software version available 2<sup>nd</sup> half 2002.



VW3 A8103●●

## PowerSuite Pocket PC

Several solutions are available to meet the needs of individual users:

- the complete Pocket PC
- the setup kit
- the connection kit for Pocket PC.

**The complete Pocket PC** comprises:

- 1 "Jordana 525" Pocket PC , with multilingual operating system (1), supplied with PC synchronisation cable and mains power supply
- 1 CD-ROM containing the multilingual (1) setup software which can be ordered separately
- 1 connection kit for Pocket PC

**The setup kit** comprises:

- 1 CD-ROM containing the multilingual (1) setup software which can be ordered separately
- 1 connection kit for the Pocket PC

The connection kit for the Pocket PC comprises:

- 2 connection cables, length 0.6 m, with 2 RJ45 connectors
- 1 RJ45/9-way SUB-D adaptor for connecting ATV 58 and ATV 58F
- 1 converter marked "RS 232/RS 485 PPC" with one 9-way male SUB-D connector and 1 RJ45 connector.
- 1 converter, for ATV 11, with one 4-way male connector and 1 RJ45 connector.

| Description                             | Reference              | Weight kg |
|---|------------------------|-----------|
| <b>Complete Pocket PC</b>               | <b>VW3 A8108●● (2)</b> | 1.000     |
| <b>Setup kit</b>                        | <b>VW3 A8102</b>       | 0.400     |
| <b>Connection kit for the Pocket PC</b> | <b>VW3 A8111</b>       | 0.300     |

## PowerSuite software workshop for PC

**The PowerSuite software** comprises:

- 1 CD-ROM containing the multilingual (1) setup software
- 1 connection kit for PC

**The PC connection kit** comprises:

- 2 connection cables, length 3 m, with 2 RJ45 connectors
- 1 RJ45/9-way SUB-D adaptor for connection of ATV-58 and ATV-58F drives
- 1 converter marked "RS 232/RS 485 PC" with one 9-way female SUB-D connector and 1 RJ45 connector
- 1 converter, for ATV 11, with one 4-way male connector and 1 RJ45 connector.

| Description  | Reference          | Weight kg |
|--|--------------------|-----------|
| <b>1 CD-ROM containing the multilingual setup software (1)</b> | <b>VW3 A8104 ▲</b> | 0.100     |
| <b>Connection kit for PC</b>                                   | <b>VW3 A8106</b>   | 0.350     |

## Magelis display unit with matrix screen

The terminal has a backlit LCD with 8 lines of 40 characters.

The RS 458 connection kits for ATV 28 (VW3 A28301), ATV 38 and ATV 58 (VW3 A58306) drives, as well as other connection accessories, should be ordered separately according to the number and type of drives connected. Please consult your Regional Sales Office.

| Description                                    | Reference             | Weight kg |
|--|-----------------------|-----------|
| <b>Magelis display unit with matrix screen</b> | <b>XBT HM017010A8</b> | 0.600     |

## Accessories

| Description   | Reference              | Weight kg |
|---|------------------------|-----------|
| <b>1 upgrade CD-ROM for multilingual (1) setup software (3)</b>                                       | <b>VW3 A8105 ▲</b>     | 0.100     |
| <b>"Jordana 525" Pocket PC terminal supplied with PC synchronisation cable and mains power supply</b> | <b>VW3 A8103●● (2)</b> | 0.300     |
| <b>1 x 16 MB compact flash card containing the Pocket PC software for the "Jornada 525" (4)</b>       | <b>VW3 A8110</b>       | 0.100     |

(1) English, French, German, Spanish, Italian.

(2) To order the operating system in your chosen language, replace ●● by EN for English, FR for French, DE for German, SP for Spanish and IT for Italian.

(3) To find out about the latest available version, please consult your Regional Sales Office.

(4) This card enables the software to be run immediately without synchronising with a PC.

▲ V 1.40 software version available 2<sup>nd</sup> half 2002.



XBT HM017010A8

# Soft starters

## Altistart 48 soft start - soft stop units

**ATS 48D17● to ATS 48D47●**

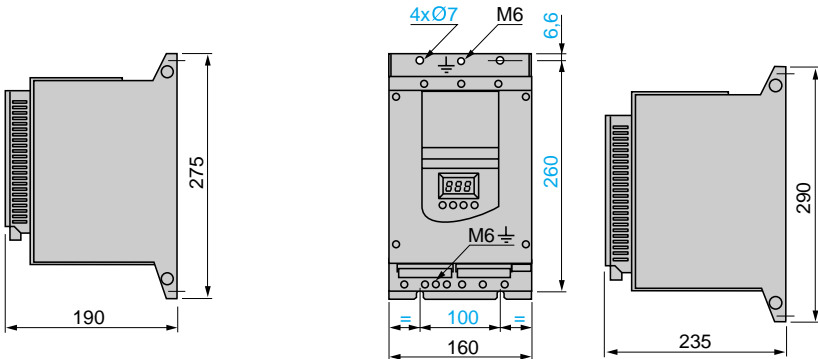

**Maximum connection capacity:**  
 Earth connections: 10 mm<sup>2</sup> (AWG 8)  
 Power terminals: 16 mm<sup>2</sup> (AWG 8)

**ATS 48D62● to ATS 48C11●**

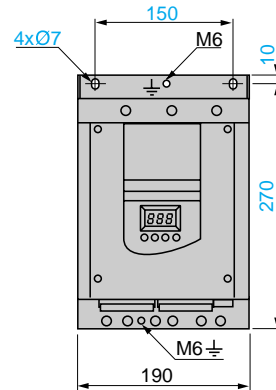

**Maximum connection capacity:**  
 Earth connections: 16 mm<sup>2</sup> (AWG 4)  
 Power terminals: 50 mm<sup>2</sup> (AWG 2/0)

**ATS 48C14● to ATS 48C17●**

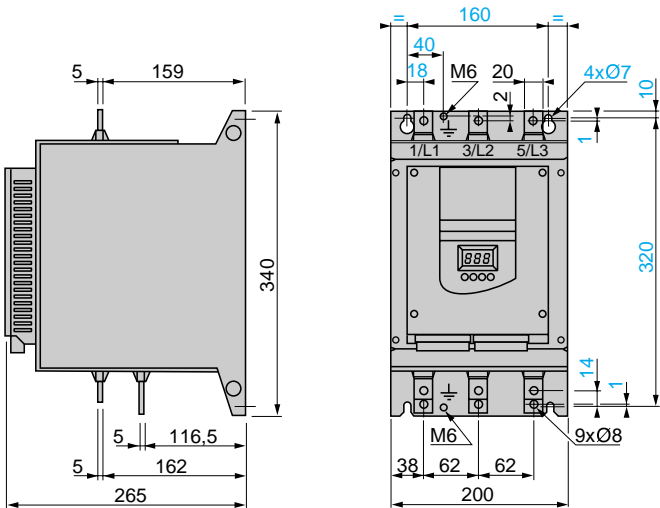

**Maximum connection capacity:**  
 Earth connections: 120 mm<sup>2</sup> (busbar)  
 Power terminals: 95 mm<sup>2</sup> (AWG 2/0)

**ATS 48C21● to ATS 48C32●**

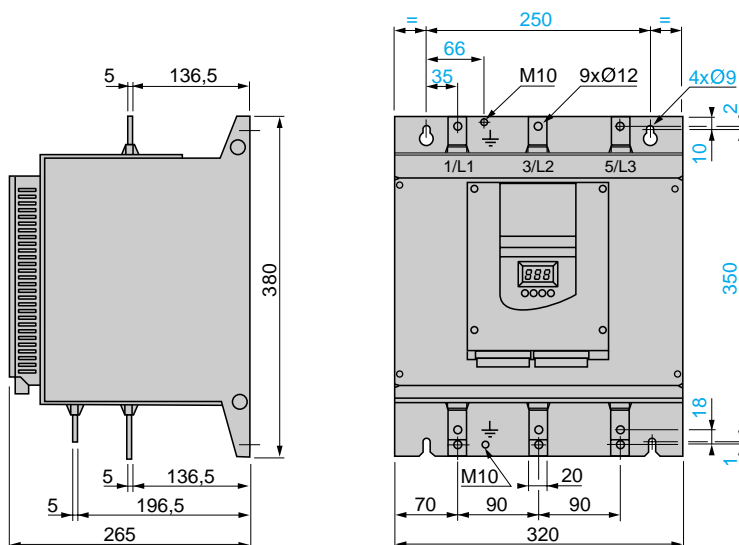

**Maximum connection capacity:**  
 Earth connections: 120 mm<sup>2</sup> (busbar)  
 Power terminals: 240 mm<sup>2</sup> (busbar)

# Soft starters

Altistart 48 soft start - soft stop units

**ATS 48C41 to C66**

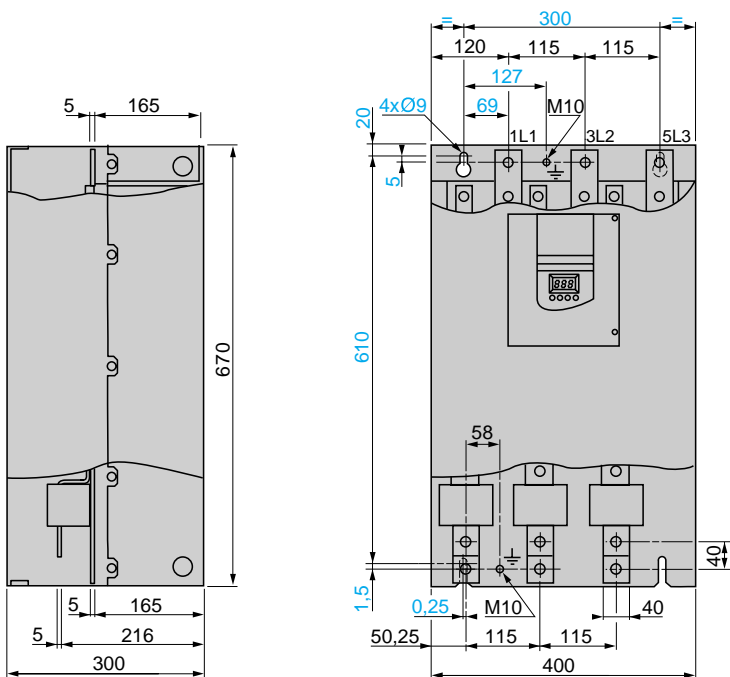

**Maximum connection capacity:**

Earth connections:  
240 mm<sup>2</sup> (busbar)  
Power terminals:  
2 x 240 mm<sup>2</sup> (busbar)

**ATS 48C79 to M12**

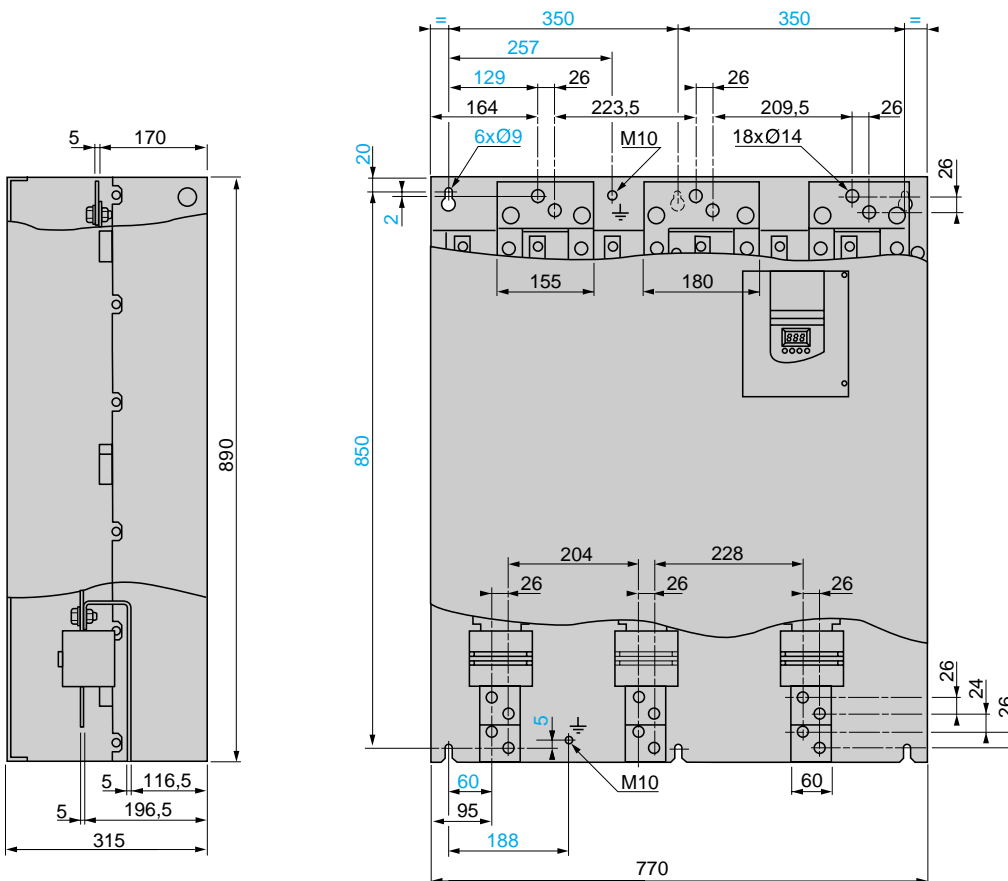

**Maximum connection capacity:**

Earth connections:  
2 x 240 mm<sup>2</sup> (busbar)  
Power terminals:  
4 x 240 mm<sup>2</sup> (busbar)

### Chokes

VZ1-L015UM17T to L070U350T

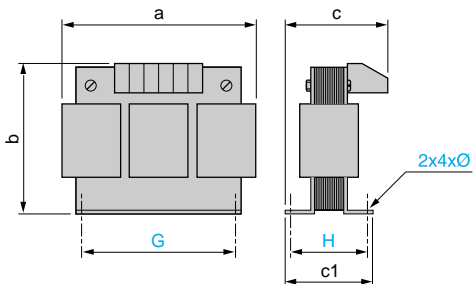

VZ1-L150U170T to LM14U016T

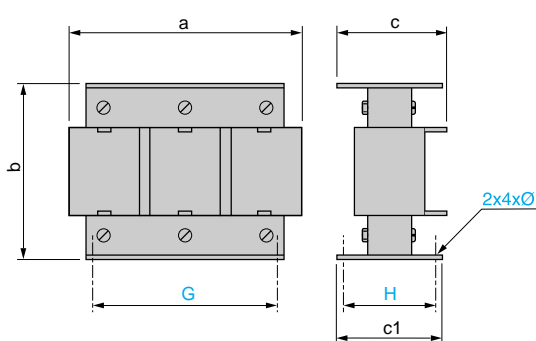

| VZ1-      | a   | b   | c   | c1  | G        | H  | Ø |
|-----------|-----|-----|-----|-----|----------|----|---|
| L015UM17T | 120 | 150 | 80  | 75  | 60/80.5  | 52 | 6 |
| L030U800T | 150 | 180 | 120 | 100 | 75/106.5 | 76 | 7 |
| L040U600T | 180 | 215 | 130 | 100 | 85/122   | 76 | 7 |
| L070U350T | 180 | 215 | 150 | 130 | 85/122   | 97 | 7 |

| VZ1-      | a   | b   | c   | c1  | G       | H   | Ø    |
|-----------|-----|-----|-----|-----|---------|-----|------|
| L150U170T | 270 | 240 | 170 | 140 | 105/181 | 96  | 11.5 |
| L250U100T | 270 | 240 | 220 | 160 | 105/181 | 125 | 11.5 |
| L325U075T | 270 | 240 | 240 | 175 | 105/181 | 138 | 11.5 |
| L530U045T | 380 | 410 | 225 | 140 | 310     | 95  | 9    |
| LM10U024T | 400 | 410 | 310 | 170 | 310     | 125 | 9    |
| LM14U016T | 420 | 490 | 340 | 170 | 310     | 125 | 9    |

### Mounting the remote terminal

VW3 G48101

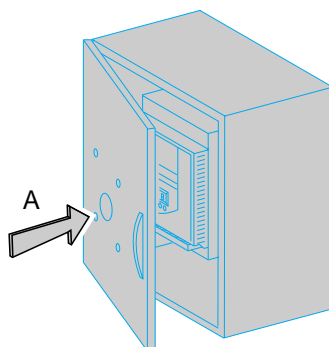
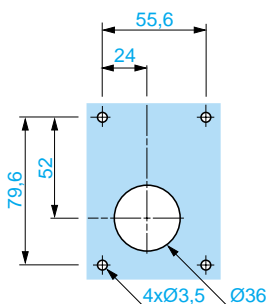

### Mounting recommendations

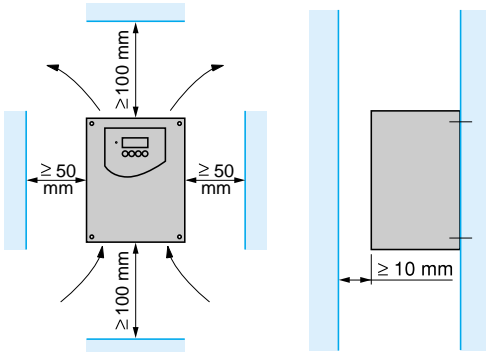

- Install the Altistart vertically, at  $\pm 10^\circ$ .
- Do not place the Altistart close to or above heating elements.
- Leave sufficient free space to ensure that the air required for cooling purposes can circulate from the bottom to the top of the unit.

**Caution:** The IP 00 version of the Altistart 48 must be fitted with a protective bar to protect personnel against electrical contact. Protective covers are available for the ATS 48C14● to ATS 48C32●. They should be ordered separately.

### Mounting in a metal wall-fixing or floor-standing enclosure with degree of protection IP 23 or IP 54

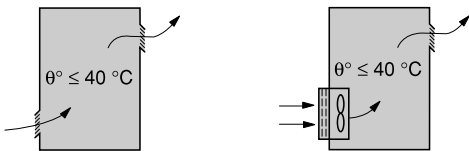

- Observe the mounting recommendations above.
- To ensure proper air circulation in the starter:
  - Fit ventilation grilles
  - Ensure that there is sufficient ventilation. If there is not, install forced ventilation with a filter. The openings and/or fans must provide a flow rate at least equal to that of the starter fans (see the table below)
- Use special filters with IP 54 protection.

### Fan flow rate depending on the starter rating

| ATS 48 starter      | Flow rate m <sup>3</sup> /hour |
|---------------------|--------------------------------|
| ATS48 D32● and D38● | 14                             |
| ATS48 D47●          | 28                             |
| ATS48 D62● to C11●  | 86                             |
| ATS48 C14● and C17● | 138                            |
| ATS48 C21● to C32●  | 280                            |
| ATS48 C41● to C66●  | 600                            |
| ATS48 C29● to M12●  | 1200                           |

**Metal wall-fixing or floor-standing enclosure with IP 54 degree of protection**  
 For non-ventilated Altistart units (ATS 48D17● and 48D22●), install a fan  $\leq 50$  mm below the starter to circulate the air inside the enclosure in order to avoid hot spots.

### Calculating the size of the enclosure

#### Maximum thermal resistance R<sub>th</sub> (°C/W)

$$R_{th} = \frac{\theta - \theta_e}{P}$$

$\theta$  = maximum temperature inside enclosure in °C  
 $\theta_e$  = maximum external temperature in °C  
 $P$  = total power dissipated in the enclosure in W

The starter/motor combinations on pages 60522/2 and 60522/3 can only be used in ambient temperatures  $\leq 40^\circ\text{C}$ .  
 For temperatures between  $40^\circ\text{C}$  and  $60^\circ\text{C}$ , derate the maximum permanent current of the starter by 2% for every degree above  $40^\circ\text{C}$ .  
 Power dissipated by the starter: see pages 60522/2 and 60522/3.  
 If the starts are infrequent, it is advisable to bypass the Altistart at the end of starting in order to reduce heat dissipation.  
 The power dissipated will then be between 15 and 30 W.  
 Add the power dissipated by the other equipment components.

#### Effective exchange surface area of enclosure S (m<sup>2</sup>)

(sides + top + front panel if wall-mounted)

$$S = \frac{K}{R_{th}}$$

K is the thermal resistance per m<sup>2</sup> of casing

For ACM type metal enclosures: K = 0.12 with internal fan, K = 0.15 without fan  
**Caution:** Do not use insulated enclosures as they have a poor level of conductivity.

### Recommended application diagram for non-reversing unit with line contactor, type 1 and type 2 coordination

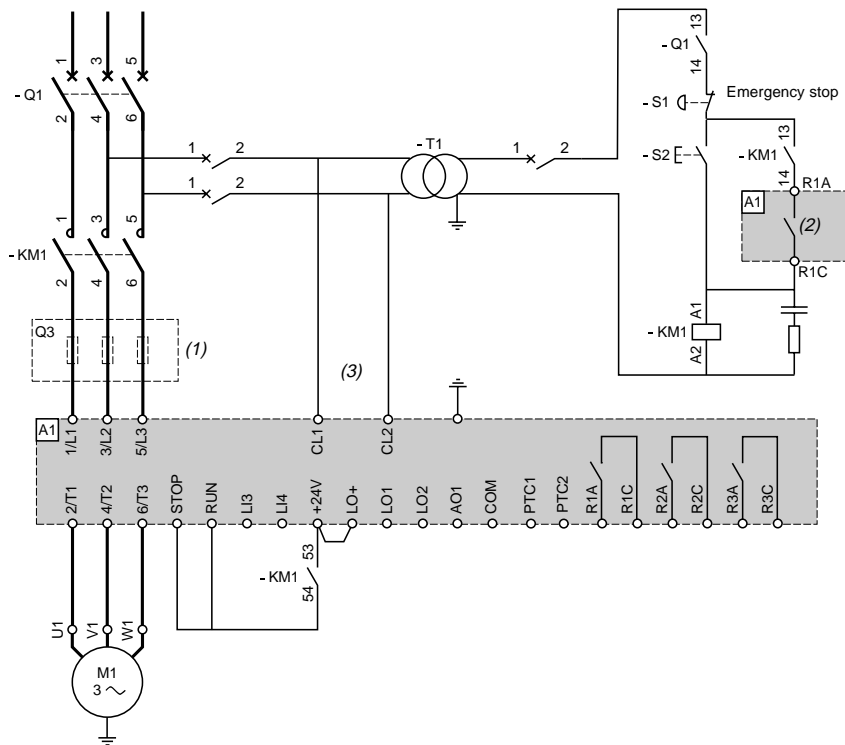

Select the components to connect, according to the descriptions on page 60524/3, from the association tables on pages 60525/2 to 60525/11.

- (1) For type 2 coordination (according to IEC 60947-4-2), install fast-acting fuses to ensure that the starter will be protected in the event of a short-circuit.
- (2) Assign relay R1 as the "isolating relay". Beware of the operating limits of the contacts (see Characteristics page 60521/2), for example when connecting to high rating contactors.
- (3) Insert a transformer if the line voltage is different to that defined for the control circuit (see page 60521/2).

#### Types of coordination

The standard defines tests for different current levels which are designed to expose the device to extreme conditions. Based on the state of the components after a short-circuit test, the standard defines 2 types of coordination.

- Type 1 coordination: Damage to the contactor and the starter is acceptable under 2 conditions:

- No risk is posed to the operator
  - Elements other than the contactor and the starter are not damaged
- Maintenance must be carried out after a short-circuit.

- Type 2 coordination: Minor soldering of the contactor contacts is permissible if they can be separated easily. The starter must not be damaged beyond repair. The protection and control devices remain operational after type 2 coordination tests. Once the fuses have been replaced, check the contactor.

**Note:** The starter will protect the motor and the cables against overloads. If this protection function is disabled, external thermal protection must be provided.

### Recommended application diagram for non-reversing unit with starter line and bypass contactors, type 1 and type 2 coordination

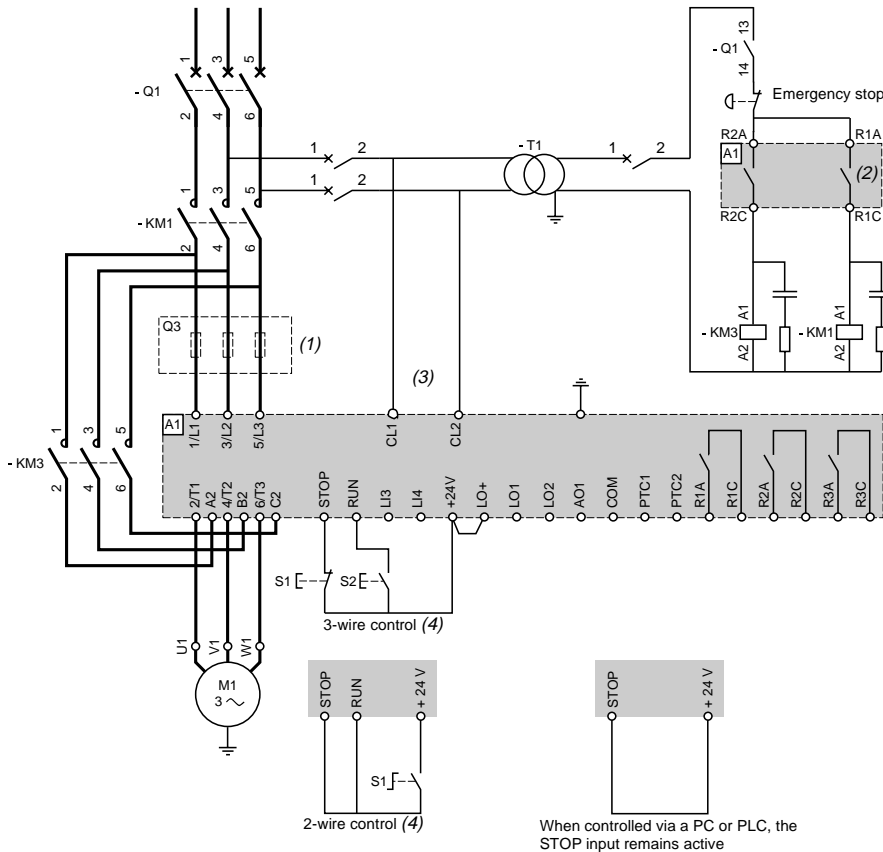

Select the components to connect, according to the descriptions below, from the association tables on pages 60525/2 to 60525/11.

- (1) For type 2 coordination (according to IEC 60947-4-2), install fast-acting fuses to ensure that the starter will be protected in the event of a short-circuit.
- (2) Assign relay R1 as the "isolating relay". Beware of the operating limits of the contacts (see Characteristics page 60521/2), for example when connecting to high rating contactors.
- (3) Insert a transformer if the line voltage is different to that defined for the control circuit (see page 60521/2).
- (4) 2-wire and 3-wire control (see page 60526/8).

### Components to connect depending on the types of coordination and voltages

| Designation | Description   |
|-------------|---|
| M1          | Motor   |
| A1          | Starter (standard applications and severe applications) |
| Q1          | Circuit-breaker or switch/fuses                         |
| Q3          | 3 FA fuses  |
| KM1, KM3    | Contactors  |
| S1, S2      | Control (separate parts XB2 or XB2 M)                   |

### Recommended application diagram for connection to the motor delta terminals, non-reversing, freewheel stop, with starter line and bypass contactors, type 1 and type 2 coordination

This type of wiring enables the starter rating to be reduced.  
ATS 48●●●Q

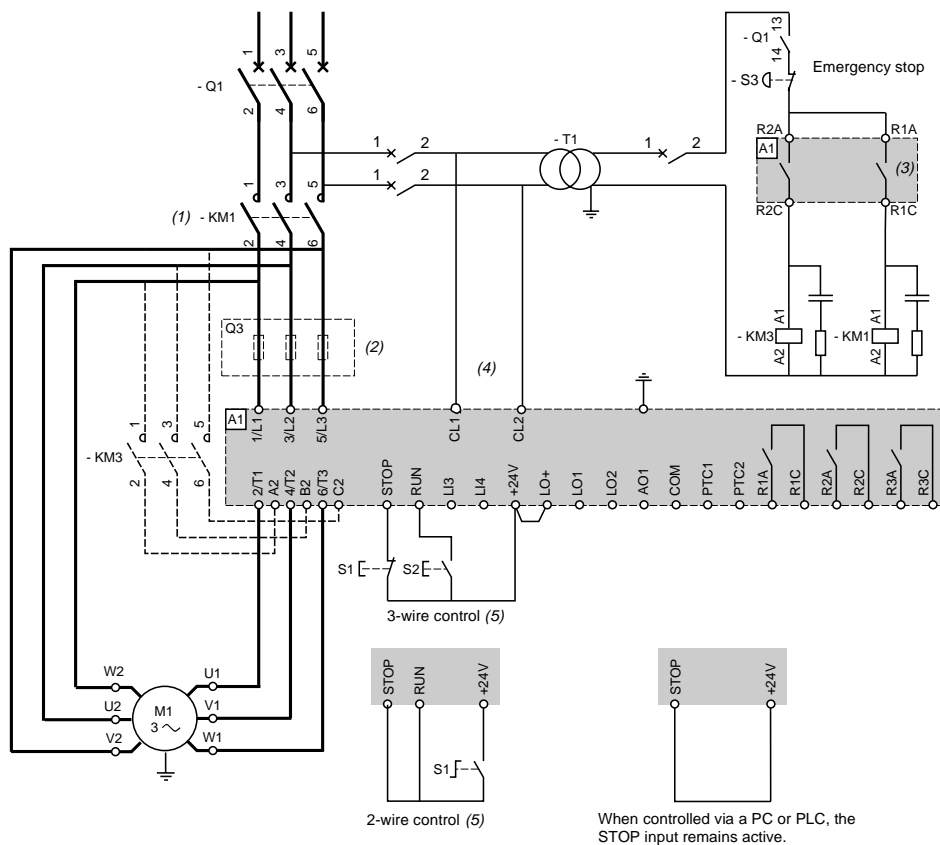

Select the components to connect according to the descriptions on page 60524/5 and the association tables on pages 60525/2 to 60525/11.

- (1) A line contactor must be used in the sequence.
- (2) For type 2 coordination (according to IEC 60947-4-2), install fast-acting fuses to ensure that the starter will be protected in the event of a short-circuit.
- (3) R1 must be assigned as the "isolating relay" to control contactor KM1. Beware of the operating limits of the contacts. (see Characteristics page 60521-2), for example when connecting to high rating contactors.
- (4) Insert a transformer if the line voltage is different to that defined for the control circuit (see page 60521/2)
- (5) 2-wire and 3-wire control (see page 60526/8).

#### Types of coordination

The standard defines tests for different current levels which are designed to expose the device to extreme conditions. Based on the state of the components after a short-circuit test, the standard defines 2 types of coordination.

- Type 1 coordination: damage to the contactor and the starter is acceptable under 2 conditions:

- No risk is posed to the operator
  - Elements other than the contactor and the starter are not damaged
- Maintenance must be carried out after a short-circuit.

- Type 2 coordination: Minor soldering of the contactor contacts is permissible if they can be separated easily. The starter must not be damaged beyond repair. The protection and control devices remain operational after type 2 coordination tests. Once the fuses have been replaced, check the contactor.

**Note:** The starter will protect the motor and the cables against overloads. If this protection function is disabled, external thermal protection must be provided.

**Recommended application diagram for LSP/HSP motor, non-reversing with starter line and bypass contactors**

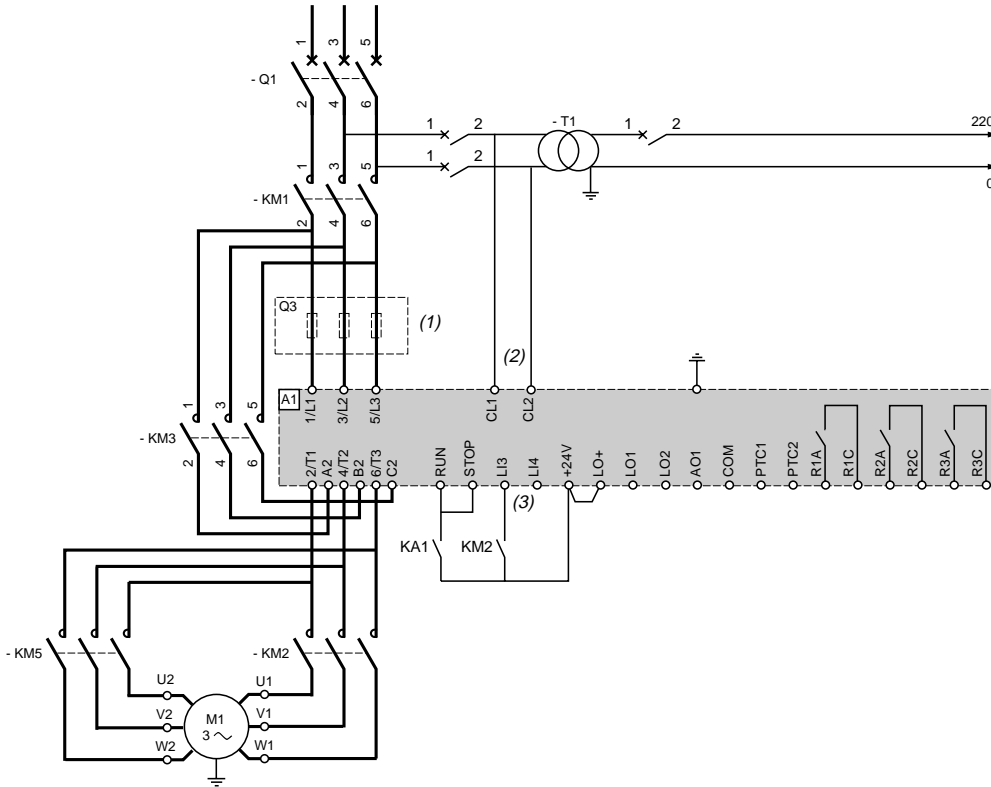

Select the components to connect, according to the descriptions below, from the association tables on pages 60525/2 to 60525/11.

- (1) For type 2 coordination (according to IEC 60947-4-2), install fast-acting fuses to ensure that the starter will be protected in the event of a short-circuit.
- (2) Insert a transformer if the line voltage is different to that defined for the control circuit (see page 60521/2).
- (3) Assign logic input LI3 to "activate the adjustment functions of the 2<sup>nd</sup> motor".
- (4) Assign relay R1 as the "isolating relay". Beware of the operating limits of the contacts (see Characteristics page 60521/2), for example when connecting to high rating contactors.

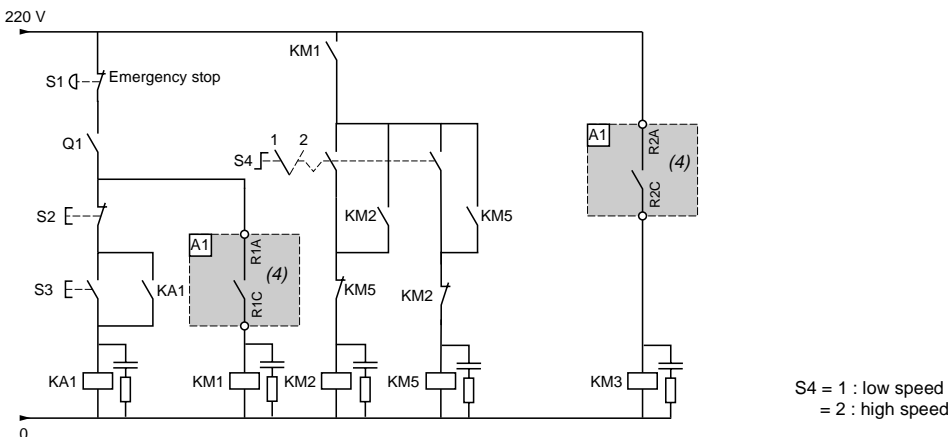

**Components to connect depending on the types of coordination and voltages**

| Designation             | Description   |
|-------------------------|---|
| M1                      | Motor   |
| A1                      | Starter (standard applications and severe applications) |
| Q1                      | Circuit-breaker or switch/fuses                         |
| Q3                      | 3 FA fuses  |
| KM1, KM2, KM3, KM5, KA1 | Contactors and relays                                   |
| S1, S2, S3              | Control (separate parts XB2 or XB2 M)                   |

### Recommended application diagram for starting and decelerating several motors cascaded with a single Altistart 48, non-reversing and line contactor

The diagram is given as an example only. For more details, refer to the Altistart 48 user's manual.

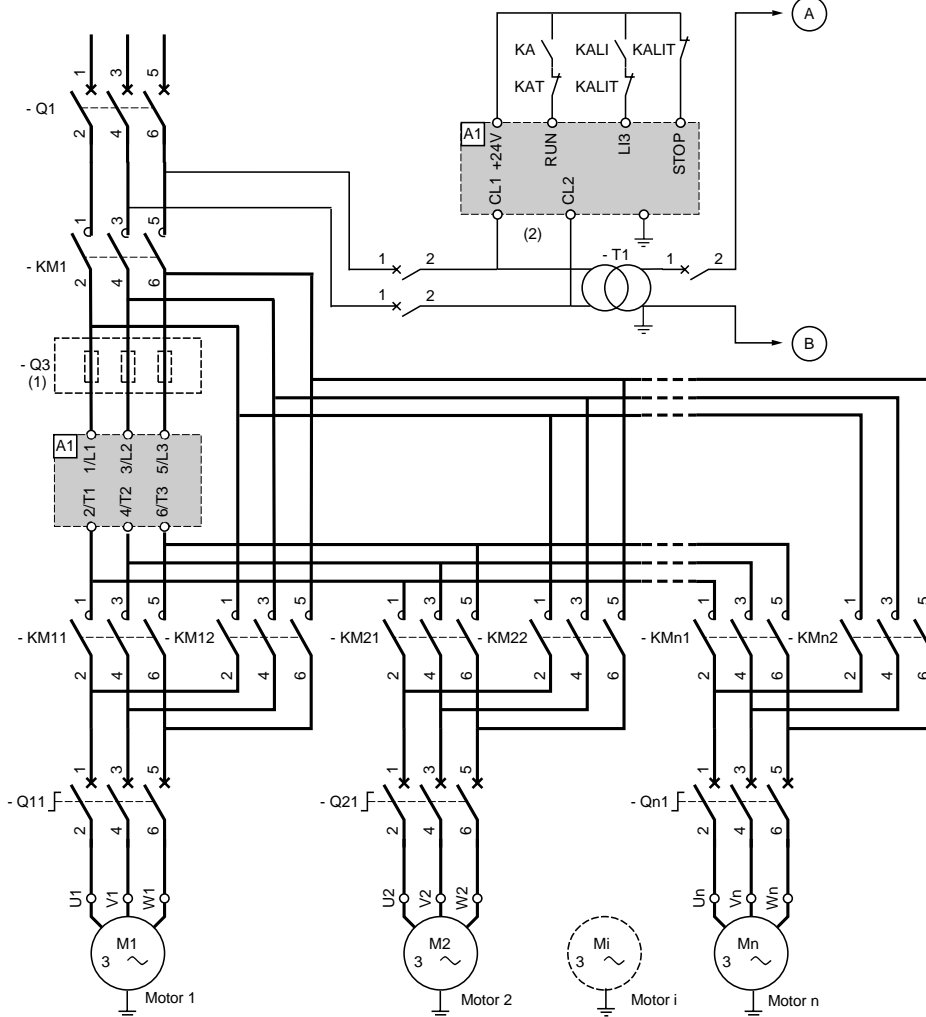

Select the components to connect, according to the designations below, from the association tables on pages 60525/2 to 60525/11.

(1) For type 2 coordination (according to IEC 60947-4-2), install fast-acting fuses to ensure that the starter will be protected in the event of a short-circuit.

(2) Insert a transformer if the line voltage is different to that defined for the control circuit (see page 60521/2).

**Important:**

- One Altistart 48 logic input must be configured as a "cascading" input.
- In the event of a fault, it will not be possible to decelerate or brake any motors that may be running at that time.
- Adjust the thermal protection of each circuit-breaker  $Q_{n1}$  for the corresponding nominal motor current.

### Components to connect depending on the types of coordination and voltages

| Designation             | Description   |
|-------------------------|---|
| M1, M2, Mi, Mn          | Motor   |
| A1                      | Starter (standard applications and severe applications) |
| KM1, KM2, ..., KMi, KMn | Contactors  |
| Q1                      | Circuit-breaker or switch/fuses                         |
| Q3                      | 3 FA fuses  |
| Q11, Q21, ..., Qn1      | Thermal magnetic circuit-breakers                       |
| KA, KAT, KALI, KALIT    | Control (separate parts XB2 or XB2 M)                   |

**Recommended application diagram for starting and decelerating several motors cascaded with a single Altistart 48, non-reversing and line contactor (continued)**

**Motor n control**

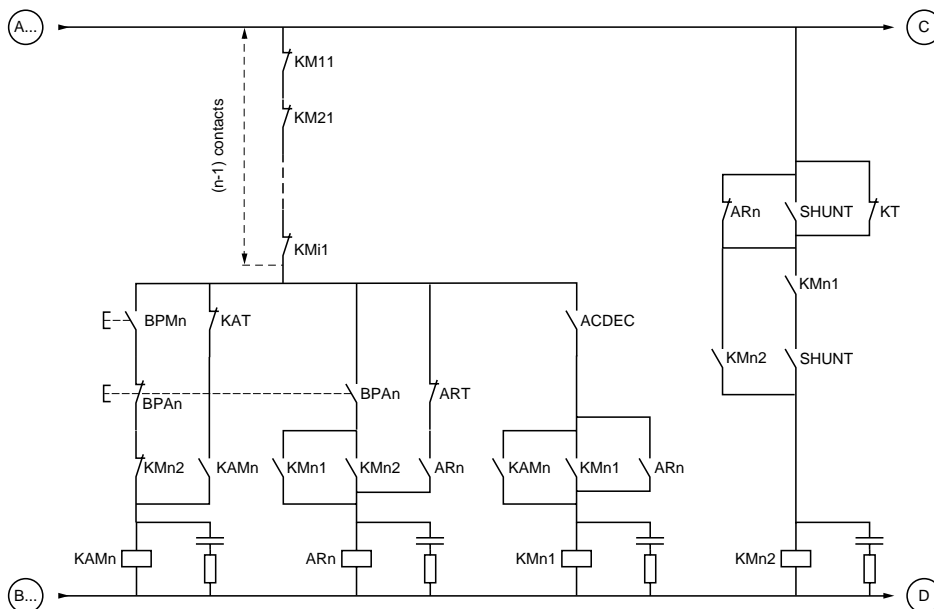

**Cascade control**

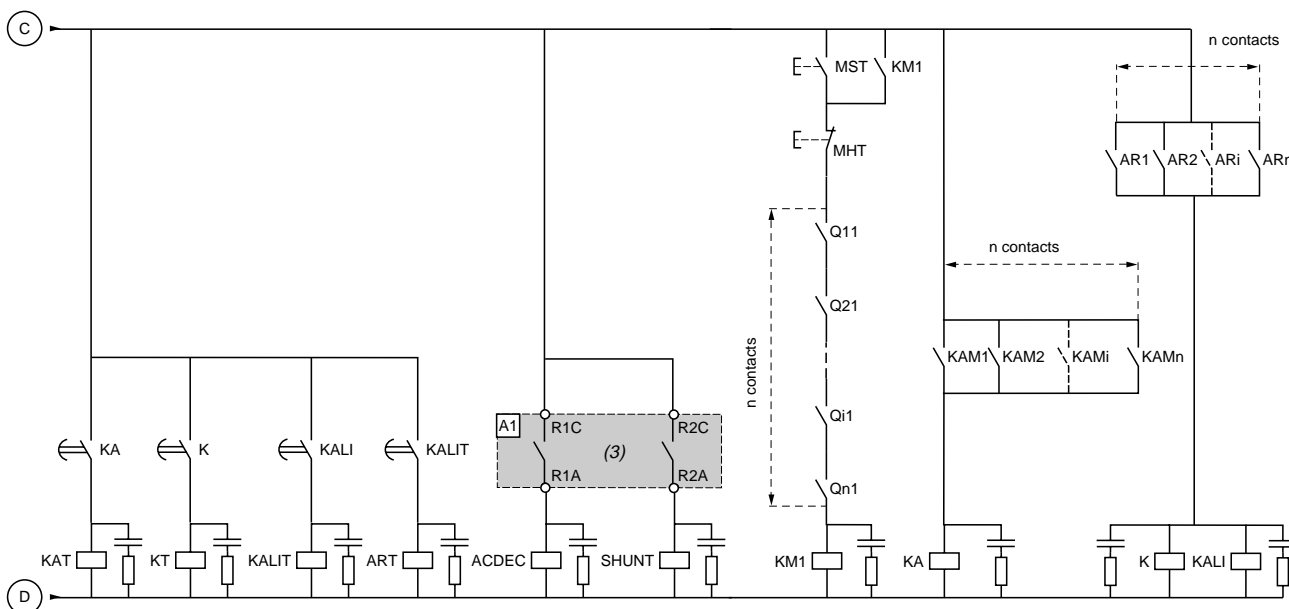

(3) Assign relay R1 as the "isolating relay". Beware of the operating limits of the contacts (see Characteristics page 60521/2), for example when connecting to high rating contactors.

- BPMn: "Run" button motor n
- BPA n: "Stop" button motor n
- MST: General "Run" button
- MHT: General "Stop" button

# Soft starters

Altistart 48 soft start - soft stop units  
230 V power supply  
Type 1 coordination

## Components for use together in accordance with standards IEC 60947-4-1 and IEC 60947-4-2 (see schemes on pages 60524/2 to 60524/7)

Combine either circuit-breaker (light blue columns), contactor, starter, or switches/fuses (dark blue columns), contactor, starter

| Motor<br>kW | A    | Starter (1)                       |                                 | Type of circuit-breaker       |             | Type of contactor | Type of switch or switch disconnector (bare unit) | Am fuses                     |              | Size    | Rating<br>A |
|-------------|------|-----------------------------------|---------------------------------|-------------------------------|-------------|-------------------|---|------------------------------|--------------|---------|-------------|
|             |      | Class 10<br>Standard applications | Class 20<br>Severe applications | Telemecanique<br>Merlin Gerin | Rating<br>A |                   |   | Reference<br>Without striker | With striker |         |             |
| M1          |      | A1                                |                                 | Q1                            |             | KM1, KM2, KM3     |   |                              |              |         |             |
| 3           | 11.5 | -                                 | ATS 48D17●                      | GV2 L20                       | 18          | LC1 D18           | LS1 D32   | DF2 CA16                     | -            | 10 x 38 | 16          |
|             |      |                                   |                                 | NS80H MA                      | 12.5        | LC1 D18           | LS1 D32   | DF2 CA16                     | -            | 10 x 38 | 16          |
| 4           | 14.5 | ATS 48D17●                        | ATS 48D22●                      | GV2 L20                       | 18          | LC1 D18           | LS1 D32   | DF2 CA16                     | -            | 10 x 38 | 16          |
|             |      |                                   |                                 | NS80H MA                      | 25          | LC1 D18           | LS1 D32   | DF2 CA16                     | -            | 10 x 38 | 16          |
| 5.5         | 20   | ATS 48D22●                        | ATS 48D32●                      | GV2 L22                       | 25          | LC1 D25           | LS1 D32   | DF2 CA25                     | -            | 10 x 38 | 25          |
|             |      |                                   |                                 | NS80H MA                      | 25          | LC1 D25           | LS1 D32   | DF2 CA25                     | -            | 10 x 38 | 25          |
| 7.5         | 27   | ATS 48D32●                        | ATS 48D38●                      | GV2 L32                       | 32          | LC1 D32           | GK1 EK  | DF2 EA32                     | DF3 EA32     | 14 x 51 | 32          |
|             |      |                                   |                                 | NS80H MA                      | 50          | LC1 D32           | GK1 EK  | DF2 EA32                     | DF3 EA32     | 14 x 51 | 32          |
| 9           | 32   | ATS 48D38●                        | ATS 48D47●                      | GK3 EF40                      | 40          | LC1 D38           | GK1 EK  | DF2 EA40                     | DF3 EA40     | 14 x 51 | 40          |
|             |      |                                   |                                 | NS80H MA                      | 50          | LC1 D38           | GK1 EK  | DF2 EA40                     | DF3 EA40     | 14 x 51 | 40          |
| 11          | 39   | ATS 48D47●                        | ATS 48D62●                      | GK3 EF65                      | 65          | LC1 D50           | GK1 FK  | DF2 FA50                     | DF3 FA50     | 22 x 58 | 50          |
|             |      |                                   |                                 | NS80H MA                      | 50          | LC1 D50           | GK1 FK  | DF2 FA50                     | DF3 FA50     | 22 x 58 | 50          |
| 15          | 52   | ATS 48D62●                        | ATS 48D75●                      | GK3 EF65                      | 65          | LC1 D65           | GK1 FK  | DF2 FA80                     | DF3 FA80     | 22 x 58 | 80          |
|             |      |                                   |                                 | NS80H MA                      | 80          | LC1 D65           | GK1 FK  | DF2 FA80                     | DF3 FA80     | 22 x 58 | 80          |
| 18.5        | 64   | ATS 48D75●                        | ATS 48D88●                      | GK3 EF80                      | 80          | LC1 D80           | GK1 FK  | DF2 FA80                     | DF3 FA80     | 22 x 58 | 80          |
|             |      |                                   |                                 | NS80H MA                      | 80          | LC1 D80           | GK1 FK  | DF2 FA80                     | DF3 FA80     | 22 x 58 | 80          |
| 22          | 75   | ATS 48D88●                        | ATS 48C11●                      | NS100● MA (2)                 | 100         | LC1 D115          | GK1 FK  | DF2 FA100                    | DF3 FA100    | 22 x 58 | 100         |
| 30          | 103  | ATS 48C11●                        | ATS 48C14●                      | NS160● MA (2)                 | 150         | LC1 D115          | GK1 FK  | DF2 FA125                    | DF4 FA125    | 22 x 58 | 125         |
| 37          | 126  | ATS 48C14●                        | ATS 48C17●                      | NS160● MA (2)                 | 150         | LC1 D150          | GS1 L   | DF2 GA1161                   | DF4 GA1161   | 0       | 160         |
| 45          | 150  | ATS 48C17●                        | ATS 48C21●                      | NS250● MA (2)                 | 220         | LC1 F185          | GS1 N   | DF2 HA1201                   | DF4 HA1201   | 1       | 200         |
| 55          | 182  | ATS 48C21●                        | ATS 48C25●                      | NS250● MA (2)                 | 220         | LC1 F225          | GS1 N   | DF2 HA1201                   | DF4 HA1201   | 1       | 200         |
| 75          | 240  | ATS 48C25●                        | ATS 48C32●                      | NS400● MA (2)                 | 320         | LC1 F265          | GS1 QQ  | DF2 JA1251                   | DF4 JA1251   | 2       | 250         |
| 90          | 295  | ATS 48C32●                        | ATS 48C41●                      | NS400● MA (2)                 | 320         | LC1 F330          | GS1 QQ  | DF2 JA1311                   | DF4 JA1311   | 2       | 315         |
| 110         | 356  | ATS 48C41●                        | ATS 48C48●                      | NS630● MA (2)                 | 500         | LC1 F400          | GS1 S   | DF2 KA1401                   | DF4 KA1401   | 3       | 400         |
| 132         | 425  | ATS 48C48●                        | ATS 48C59●                      | NS630● MA (2)                 | 500         | LC1 F500          | GS1 S   | DF2 KA1501                   | DF4 KA1501   | 3       | 500         |
| 160         | 520  | ATS 48C59●                        | ATS 48C66●                      | NS630b● (2)<br>Micrologic 5.0 | 630         | LC1 F630          | GS1 S   | DF2 KA1631                   | DF4 KA1631   | 3       | 630         |
|             |      |                                   |                                 | C801● (2)<br>STR35 ME         | 800         | LC1 F630          | GS1 S   | DF2 KA1631                   | DF4 KA1631   | 3       | 630         |
| -           | -    | ATS 48C66●                        | ATS 48C79●                      | NS800● (2)<br>Micrologic 5.0  | 800         | LC1 F800          | GS1 S   | DF2 KA1631                   | DF4 KA1631   | 3       | 630         |
|             |      |                                   |                                 | C801● (2)<br>STR35 ME         | 800         | LC1 F800          | GS1 S   | DF2 KA1631                   | DF4 KA1631   | 3       | 630         |
| 220         | 700  | ATS 48C79●                        | ATS 48M10●                      | NS800● (2)<br>Micrologic 5.0  | 800         | LC1 F800          | GS1 V   | DF2 LA1801                   | DF4 LA1801   | 4       | 800         |
|             |      |                                   |                                 | C801● (2)<br>STR35 ME         | 800         | LC1 F800          | GS1 V   | DF2 LA1801                   | DF4 LA1801   | 4       | 800         |
| 250         | 800  | ATS 48M10●                        | ATS 48M12●                      | NS1000● (2)<br>Micrologic 5.0 | 1000        | LC1 BM33          | GS1 V   | DF2 LA1101                   | DF4 LA1101   | 4       | 1000        |
|             |      |                                   |                                 | C1001● (2)<br>STR35 ME        | 1000        | LC1 BM33          | GS1 V   | DF2 LA1101                   | DF4 LA1101   | 4       | 1000        |
| 355         | 1115 | ATS 48M12●                        | -                               | NS1250● (2)<br>Micrologic 5.0 | 1250        | LC1BP33           | -   | DF2 LA1251                   | DF4 LA1251   | 4       | 1250        |
|             |      |                                   |                                 | C1251● (2)<br>STR35 ME        | 1250        | LC1BP33           | -   | DF2 LA1251                   | DF4 LA1251   | 4       | 1250        |

(1) Replace ● with Q or Y according to the starter voltage range.

(2) Replace ● with N, H or L, according to the breaking capacity (see table below).

### Breaking capacity of circuit-breakers according to standard IEC 60947-2

| 230 V                                | Icu (kA)   |
|--------------------------------------|------------|
| GV2 L20, GK3 EF40, NS80              | 100        |
| GV2 L22, GV2 L32, GK3 EF65, GK3 EF80 | 50         |
| 230 V                                | Icu (kA)   |
|                                      | N H L      |
| NS100, NS160, NS250, NS400, NS630    | 85 100 150 |
| NS800, NS1000                        | 50 70 150  |
| NS1250                               | 50 70 -    |
| C801, C1001                          | 85 100 150 |
| C1251                                | 85 100 -   |

### Maximum prospective short-circuit current of the starter according to standard IEC 60947-4-2

| Starter                  | Iq (kA) |
|--------------------------|---------|
| ATS 48D17● to ATS 48C32● | 50      |
| ATS 48C41● to ATS 48M12● | 70      |

## Soft starters

Altistart 48 soft start - soft stop units

230 V power supply

Type 2 coordination

### Components for use together in accordance with standards IEC 60947-4-1 and IEC 60947-4-2 (see schemes on pages 60524/2 to 60524/7) circuit-breakers, contactors, fast-acting fuses, starters

Combination: circuit-breaker, contactor, starter

| Motor |      | Starter (1)           |                     | Type of circuit-breaker        | Rating | Type of contactor |
|-------|------|-----------------------|---------------------|--------------------------------|--------|-------------------|
| kW    | A    | Class 10              | Class 20            | Telemecanique<br>Merlin Gerin  | A      |                   |
|       |      | Standard applications | Severe applications |                                |        |                   |
| M1    |      | A1                    |                     | Q1                             |        | KM1, KM2, KM3     |
| 3     | 11.5 | -                     | ATS 48D17●          | GV2 L20                        | 18     | LC1 D40           |
|       |      |                       |                     | NS80H MA                       | 12.5   | LC1 D40           |
| 4     | 14.5 | ATS 48D17●            | ATS 48D22●          | GV2 L20                        | 18     | LC1 D40           |
|       |      |                       |                     | NS80H MA                       | 25     | LC1 D40           |
| 5.5   | 20   | ATS 48-D22●           | ATS 48D32●          | GV2 L22                        | 25     | LC1 D40           |
|       |      |                       |                     | NS80H MA                       | 25     | LC1 D40           |
| 7.5   | 27   | ATS 48D32●            | ATS 48D38●          | GV2 L32                        | 32     | LC1 D80           |
|       |      |                       |                     | NS80H MA                       | 50     | LC1 D80           |
| 9     | 32   | ATS 48D38●            | ATS 48D47●          | GK3 EF40                       | 40     | LC1 D80           |
|       |      |                       |                     | NS80H MA                       | 50     | LC1 D80           |
| 11    | 39   | ATS 48D47●            | ATS 48D62●          | GK3 EF65                       | 65     | LC1 D80           |
|       |      |                       |                     | NS80H MA                       | 50     | LC1 D80           |
| 15    | 52   | ATS 48D62●            | ATS 48D75●          | GK3 EF65                       | 65     | LC1 D80           |
|       |      |                       |                     | NS80H MA                       | 80     | LC1 D80           |
| 18.5  | 64   | ATS 48D75●            | ATS 48D88●          | GK3 EF80                       | 80     | LC1 D80           |
|       |      |                       |                     | NS80H MA                       | 80     | LC1 D80           |
| 22    | 75   | ATS 48D88●            | ATS 48C11●          | NS100● MA (2)                  | 100    | LC1 D115          |
| 30    | 103  | ATS 48C11●            | ATS 48C14●          | NS160● MA (2)                  | 150    | LC1 D115          |
| 37    | 126  | ATS 48C14●            | ATS 48C17●          | NS160● MA (2)                  | 150    | LC1 D150          |
| 45    | 150  | ATS 48C17●            | ATS 48C21●          | NS250● MA (2)                  | 220    | LC1 F185          |
| 55    | 182  | ATS 48C21●            | ATS 48C25●          | NS250● MA (2)                  | 220    | LC1 F225          |
| 75    | 240  | ATS 48C25●            | ATS 48C32●          | NS400● MA (2)                  | 320    | LC1 F265          |
| 90    | 295  | ATS 48C32●            | ATS 48C41●          | NS400● MA (2)                  | 320    | LC1 F330          |
| 110   | 356  | ATS 48C41●            | ATS 48C48●          | NS630● MA (2)                  | 500    | LC1 F400          |
| 132   | 425  | ATS 48C48●            | ATS 48C59●          | NS630● MA (2)                  | 500    | LC1 F500          |
| 160   | 520  | ATS 48C59●            | ATS 48C66●          | NS630bL Micrologic 5.0         | 630    | LC1 F630          |
| 200   | 626  | ATS 48C66●            | ATS 48C79●          | NS800L Micrologic 5.0          | 800    | LC1 F800          |
| 220   | 700  | ATS 48C79●            | ATS 48M10●          | NS800L Micrologic 5.0          | 800    | LC1 F800          |
| 250   | 800  | ATS 48M10●            | ATS 48M12●          | NS1000L Micrologic 5.0         | 1000   | LC1 BM33          |
| 355   | 1115 | ATS 48M12●            | -                   | NS1250● (2) Micrologic 5.0 (3) | 1250   | LC1 BP33          |

(1) Replace ● with Q or Y according to the starter voltage range.

(2) Replace ● with N, H or L, according to the breaking capacity (see the breaking capacity table on the previous page).

(3) Type 2 coordination is only possible if the fast-acting fuses remain in the motor supply circuit and are not bypassed at the end of starting.

#### Fast-acting fuse (essential for type 2 coordination), starter combinations

| Starter Reference  | Fast-acting fuses      |         |  |
|--|------------------------|---------|--|
|  | Reference              | Size    | Rating A<br>I <sub>t</sub><br>kA <sup>2</sup> .s |
| A1   | Q3                     |         |  |
| ATS 48D17●   | DF3 ER50               | 14 x 51 | 50 2.3   |
| ATS 48D22● and ATS 48D32●  | DF3 FR80               | 22 x 58 | 80 5.6   |
| ATS 48D38● and ATS 48D47●  | DF3 FR100              | 22 x 58 | 100 12   |
| ATS 48D62● and ATS 48D75●  | DF4 00125              | 00      | 125 45   |
| ATS 48D88● and ATS 48C11●  | DF4 00160              | 00      | 160 82   |
| ATS 48C14● and ATS 48C17●  | DF4 30400              | 30      | 400 120  |
| ATS 48C21● to ATS 48C32●   | DF4 31700              | 31      | 700 490  |
| ATS 48D75●   | DF4 33800              | 33      | 800 490  |
| ATS 48C48● and ATS 48C59●  | DF4 331000             | 33      | 1000 900   |
| ATS 48C66●   | DF4 2331400            | 2 x 33  | 1400 1200  |
| ATS 48C79●   | DF4 441600             | 44      | 1600 1600  |
| ATS 48M10● and ATS 48M12●  | DF4 442200             | 44      | 2200 4100  |
| Maximum prospective short-circuit current of the starter according to standard IEC 60947-4-2 |                        |         |  |
| Starter  | I <sub>q</sub><br>(kA) |         |  |
| ATS 48D17● to ATS 48C79●   | 50                     |         |  |
| ATS 48M10● and ATS 48M12●  | 85                     |         |  |

# Soft starters

Altistart 48 soft start - soft stop units  
380 V, 400 V, 415 V power supply  
Type 1 coordination

## Components for use together in accordance with standards IEC 60947-4-1 and IEC 60947-4-2 (see schemes on pages 60524/2 to 60524/7)

Combine either circuit-breaker (light blue columns), contactor, starter, or switches/fuses (dark blue columns), contactor, starter

| Motor<br>kW | A    | Starter (1)                       |                                 | Type of circuit-breaker       |             | Type of contactor | Type of switch or switch disconnector (bare unit) | Am fuses                     |              | Size    | Rating<br>A |
|-------------|------|-----------------------------------|---------------------------------|-------------------------------|-------------|-------------------|---|------------------------------|--------------|---------|-------------|
|             |      | Class 10<br>Standard applications | Class 20<br>Severe applications | Telemecanique<br>Merlin Gerin | Rating<br>A |                   |   | Reference<br>Without striker | With striker |         |             |
| M1          |      | A1                                |                                 | Q1                            |             | KM1, KM2, KM3     |   |                              |              |         |             |
| 5.5         | 11   | -                                 | ATS 48D17●                      | GV2 L20                       | 18          | LC1 D18           | LS1 D32   | DF2 CA16                     | -            | 10 x 38 | 16          |
|             |      |                                   |                                 | NS80H MA                      | 12.5        | LC1 D18           | LS1 D32   | DF2 CA16                     | -            | 10 x 38 | 16          |
| 7.5         | 14.8 | ATS 48D17●                        | ATS 48D22●                      | GV2 L20                       | 18          | LC1 D18           | LS1 D32   | DF2 CA16                     | -            | 10 x 38 | 16          |
|             |      |                                   |                                 | NS80H MA                      | 25          | LC1 D18           | LS1 D32   | DF2 CA16                     | -            | 10 x 38 | 16          |
| 11          | 21   | ATS 48D22●                        | ATS 48D32●                      | GV2 L22                       | 25          | LC1 D25           | LS1 D32   | DF2 CA25                     | -            | 10 x 38 | 25          |
|             |      |                                   |                                 | NS80H MA                      | 25          | LC1 D25           | LS1 D32   | DF2 CA25                     | -            | 10 x 38 | 25          |
| 15          | 28.5 | ATS 48D32●                        | ATS 48D38●                      | GV2 L32                       | 32          | LC1 D32           | GK1 EK  | DF2 EA32                     | DF3 EA32     | 14 x 51 | 32          |
|             |      |                                   |                                 | NS80H MA                      | 50          | LC1 D32           | GK1 EK  | DF2 EA32                     | DF3 EA32     | 14 x 51 | 32          |
| 18.5        | 35   | ATS 48D38●                        | ATS 48D47●                      | GK3 EF40                      | 40          | LC1 D38           | GK1 EK  | DF2 EA40                     | DF3 EA40     | 14 x 51 | 40          |
|             |      |                                   |                                 | NS80H MA                      | 50          | LC1 D38           | GK1 EK  | DF2 EA40                     | DF3 EA40     | 14 x 51 | 40          |
| 22          | 42   | ATS 48D47●                        | ATS 48D62●                      | GK3 EF65                      | 65          | LC1 D50           | GK1 FK  | DF2 FA50                     | DF3 FA50     | 22 x 58 | 50          |
|             |      |                                   |                                 | NS80H MA                      | 50          | LC1 D50           | GK1 FK  | DF2 FA50                     | DF3 FA50     | 22 x 58 | 50          |
| 30          | 57   | ATS 48D62●                        | ATS 48D75●                      | GK3 EF65                      | 65          | LC1 D65           | GK1 FK  | DF2 FA80                     | DF3 FA80     | 22 x 58 | 80          |
|             |      |                                   |                                 | NS80H MA                      | 80          | LC1 D65           | GK1 FK  | DF2 FA80                     | DF3 FA80     | 22 x 58 | 80          |
| 37          | 69   | ATS 48D75●                        | ATS 48D88●                      | GK3 EF80                      | 80          | LC1 D80           | GK1 FK  | DF2 FA80                     | DF3 FA80     | 22 x 58 | 80          |
|             |      |                                   |                                 | NS80H MA                      | 80          | LC1 D80           | GK1 FK  | DF2 FA80                     | DF3 FA80     | 22 x 58 | 80          |
| 45          | 81   | ATS 48D88●                        | ATS48C11●                       | NS100● MA (2)                 | 100         | LC1 D115          | GK1 FK  | DF2 FA100                    | DF3 FA100    | 22 x 58 | 100         |
| 55          | 100  | ATS 48C11●                        | ATS 48C14●                      | NS160● MA (2)                 | 150         | LC1 D115          | GK1 FK  | DF2 FA125                    | DF4 FA125    | 22 x 58 | 125         |
| 75          | 131  | ATS 48C14●                        | ATS 48C17●                      | NS160● MA (2)                 | 150         | LC1 D150          | GS1 L   | DF2 GA1161                   | DF4 GA1161   | 0       | 160         |
| 90          | 162  | ATS 48C17●                        | ATS 48C21●                      | NS250● MA (2)                 | 220         | LC1 F185          | GS1 N   | DF2 HA1201                   | DF4 HA1201   | 1       | 200         |
| 110         | 195  | ATS 48C21●                        | ATS 48C25●                      | NS250● MA (2)                 | 220         | LC1 F225          | GS1 N   | DF2 HA1201                   | DF4 HA1201   | 1       | 200         |
| 132         | 233  | ATS 48C25●                        | ATS 48C32●                      | NS400● MA (2)                 | 320         | LC1 F265          | GS1 QQ  | DF2 JA1251                   | DF4 JA1251   | 2       | 250         |
| 160         | 285  | ATS 48C32●                        | ATS 48C41●                      | NS400● MA (2)                 | 320         | LC1 F330          | GS1 QQ  | DF2 JA1311                   | DF4 JA1311   | 2       | 315         |
| 220         | 388  | ATS 48C41●                        | ATS 48C48●                      | NS630● MA (2)                 | 500         | LC1 F400          | GS1 S   | DF2 KA1401                   | DF4 KA1401   | 3       | 400         |
| 250         | 437  | ATS 48C48●                        | ATS 48C59●                      | NS630● MA (2)                 | 500         | LC1 F500          | GS1 S   | DF2 KA1501                   | DF4 KA1501   | 3       | 500         |
| 315         | 560  | ATS 48C59●                        | ATS 48C66●                      | NS630b● (2)<br>Micrologic 5.0 | 630         | LC1 F630          | GS1 S   | DF2 KA1631                   | DF4 KA1631   | 3       | 630         |
|             |      |                                   |                                 | C801● (2)<br>STR35ME          | 800         | LC1 F630          | GS1 S   | DF2 KA1631                   | DF4 KA1631   | 3       | 630         |
| 355         | 605  | ATS 48C66●                        | ATS 48C79●                      | NS800● (2)<br>Micrologic 5.0  | 800         | LC1 F800          | GS1 V   | DF2 LA1631                   | DF4 LA1631   | 4       | 630         |
|             |      |                                   |                                 | C801● (2)<br>STR35ME          | 800         | LC1 F800          | GS1 V   | DF2 LA1631                   | DF4 LA1631   | 4       | 630         |
| 400         | 675  | ATS 48C79●                        | ATS 48M10●                      | NS800● (2)<br>Micrologic 5.0  | 800         | LC1 F800          | GS1 V   | DF2 LA1801                   | DF4 LA1801   | 4       | 800         |
|             |      |                                   |                                 | C801● (2)<br>STR35ME          | 800         | LC1 F800          | GS1 V   | DF2 LA1801                   | DF4 LA1801   | 4       | 800         |
| 500         | 855  | ATS 48M10●                        | ATS 48M12●                      | NS1000● (2)<br>Micrologic 5.0 | 1000        | LC1 BM33          | GS1 V   | DF2 LA1101                   | DF4 LA1101   | 4       | 1000        |
|             |      |                                   |                                 | C1001● (2)<br>STR35ME         | 1000        | LC1 BM33          | GS1 V   | DF2 LA1101                   | DF4 LA1101   | 4       | 1000        |
| 630         | 1045 | ATS48M12●                         | -                               | NS1250● (2)<br>Micrologic 5.0 | 1250        | LC1 BP33          | -   | DF2 LA1251                   | DF4 LA1251   | 4       | 1250        |
|             |      |                                   |                                 | C1251● (2)<br>STR35ME         | 1250        | LC1 BP33          | -   | DF2 LA1251                   | DF4 LA1251   | 4       | 1250        |

(1) Replace ● with Q or Y according to the starter voltage range.  
(2) Replace ● with N, H or L, according to the breaking capacity (see table below).

| Maximum prospective short-circuit current of the starter according to IEC 60947-4-2 | Iq (kA) | Breaking capacity of circuit-breakers according to standard IEC 60947-2 |          |    |     |
|---|---------|---|----------|----|-----|
|   |         | 380 V, 400 V, 415 V   |          |    |     |
| Starter   | Iq (kA) | Icu (kA)  |          |    |     |
| ATS 48D17● to ATS 48C32●  | 50      | GV2 L20, GV2 L22, GV2 L32   | 50       |    |     |
| ATS 48C41● to ATS 48M12●  | 70      | GK3 EF40  | 50       |    |     |
|   |         | GK3 EF65, GK3 EF80  | 35       |    |     |
|   |         | NS80  | 70       |    |     |
|   |         | 380 V, 400 V, 415 V   | Icu (kA) |    |     |
|   |         |   | N        | H  | L   |
|   |         | NS100   | 25       | 70 | 150 |
|   |         | NS160, NS250  | 36       | 70 | 150 |
|   |         | NS400, NS630  | 45       | 70 | 150 |
|   |         | NS800, NS1000   | 50       | 70 | 150 |
|   |         | NS1250  | 50       | 70 | -   |
|   |         | C801, C1001   | 50       | 70 | 150 |
|   |         | C1251   | 50       | 70 | -   |

## Soft starters

Altistart 48 soft start - soft stop units

380 V, 400 V, 415 V power supply

Type 2 coordination

### Components for use together in accordance with standards IEC 60947-4-1 and IEC 60947-4-2 (see schemes on pages 60524/2 to 60524/7) circuit-breakers, contactors, fast-acting fuses, starters

Combination: circuit-breaker, contactor, starter

| Motor |      | Starter (1)           |                     | Type of circuit-breaker        | Rating | Type of contactor |
|-------|------|-----------------------|---------------------|--------------------------------|--------|-------------------|
| kW    | A    | Class 10              | Class 20            | Telemecanique<br>Merlin Gerin  | A      |                   |
|       |      | Standard applications | Severe applications |                                |        |                   |
| M1    |      | A1                    |                     | Q1                             |        | KM1, KM2, KM3     |
| 5.5   | 11   | -                     | ATS 48D17●          | GV2 L20                        | 18     | LC1 D40           |
|       |      |                       |                     | NS80H MA                       | 12.5   | LC1 D40           |
| 7.5   | 14.8 | ATS 48D17●            | ATS 48D22●          | GV2 L20                        | 18     | LC1 D40           |
|       |      |                       |                     | NS80H MA                       | 25     | LC1 D40           |
| 11    | 21   | ATS 48D22●            | ATS 48D32●          | GV2 L22                        | 25     | LC1 D40           |
|       |      |                       |                     | NS80H MA                       | 25     | LC1 D40           |
| 15    | 28.5 | ATS 48D32●            | ATS 48D38●          | GV2 L32                        | 32     | LC1 D80           |
|       |      |                       |                     | NS80H MA                       | 50     | LC1 D80           |
| 18.5  | 35   | ATS 48D38●            | ATS 48D47●          | NS80H MA                       | 50     | LC1 D80           |
| 22    | 42   | ATS 48D47●            | ATS 48D62●          | NS80H MA                       | 50     | LC1 D80           |
| 30    | 57   | ATS 48D62●            | ATS 48D75●          | NS80H MA                       | 80     | LC1 D80           |
| 37    | 69   | ATS 48D75●            | ATS 48D88●          | NS80H MA                       | 80     | LC1 D80           |
| 45    | 81   | ATS 48D88●            | ATS 48C11●          | NS100● MA (2)                  | 100    | LC1 D115          |
| 55    | 100  | ATS 48C11●            | ATS 48C14●          | NS160● MA (2)                  | 150    | LC1 D115          |
| 75    | 131  | ATS 48C14●            | ATS 48C17●          | NS160● MA (2)                  | 150    | LC1 D150          |
| 90    | 162  | ATS 48C17●            | ATS 48C21●          | NS 250● MA (2)                 | 220    | LC1 F185          |
| 110   | 195  | ATS 48C21●            | ATS 48C25●          | NS 250● MA (2)                 | 220    | LC1 F225          |
| 132   | 233  | ATS 48C25●            | ATS 48C32●          | NS400● MA (2)                  | 320    | LC1 F265          |
| 160   | 285  | ATS 48C32●            | ATS 48C41●          | NS400● MA (2)                  | 320    | LC1 F330          |
| 220   | 388  | ATS 48C41●            | ATS 48C48●          | NS630● MA (2)                  | 500    | LC1 F500          |
| 250   | 437  | ATS 48C48●            | ATS 48C59●          | NS630● MA (2)                  | 500    | LC1 F500          |
| 315   | 560  | ATS 48C59●            | ATS 48C66●          | NS630bL Micrologic 5.0         | 630    | LC1 F630          |
| 355   | 605  | ATS48C66●             | ATS48C79●           | NS800L Micrologic 5.0          | 800    | LC1 F800          |
| 400   | 675  | ATS48C79●             | ATS48M10●           | NS800L Micrologic 5.0          | 800    | LC1 F800          |
| 500   | 855  | ATS48M10●             | ATS48M12●           | NS1000L Micrologic 5.0         | 1000   | LC1 BM33          |
| 630   | 1045 | ATS48M12●             | -                   | NS1250● (2) Micrologic 5.0 (3) | 1250   | LC1 BP33          |

(1) Replace ● with Q or Y according to the starter voltage range.

(2) Replace ● with N, H or L, according to the breaking capacity (see the breaking capacity table on the previous page).

(3) Type 2 coordination is only possible if the fast-acting fuses remain in the motor supply circuit and are not bypassed at the end of starting.

#### Fast-acting fuse (essential for type 2 coordination), starter combinations

| Starter Reference         | Fast-acting fuses |         |          |                                    |
|---------------------------|-------------------|---------|----------|------------------------------------|
|                           | Reference         | Size    | Rating A | I <sub>pt</sub> kA <sup>2</sup> .s |
| A1                        | Q3                |         |          |                                    |
| ATS 48D17●                | DF3 ER50          | 14 x 51 | 50       | 2.3                                |
| ATS 48D22● and ATS 48D32● | DF3 FR80          | 22 x 58 | 80       | 5.6                                |
| ATS 48D38● and ATS 48D47● | DF3 FR100         | 22 x 58 | 100      | 12                                 |
| ATS 48D62● and ATS 48D75● | DF4 00125         | 00      | 125      | 45                                 |
| ATS 48D88● and ATS 48C11● | DF4 00160         | 00      | 160      | 82                                 |
| ATS 48C14● and ATS 48C17● | DF4 30400         | 30      | 400      | 120                                |
| ATS 48C21● to ATS 48C32●  | DF4 31700         | 31      | 700      | 490                                |
| ATS 48D75●                | DF4 33800         | 33      | 800      | 490                                |
| ATS 48C48● and ATS 48C59● | DF4 331000        | 33      | 1000     | 900                                |
| ATS 48C66●                | DF4 2331400       | 2 x 33  | 1400     | 1200                               |
| ATS 48C79●                | DF4 441600        | 44      | 1600     | 1600                               |
| ATS 48M10● and ATS 48M12● | DF4 442200        | 44      | 2200     | 4100                               |

Maximum prospective short-circuit current of the starter according to standard IEC 60947-4-2

| Starter                   | I <sub>q</sub> (kA) |
|---------------------------|---------------------|
| ATS 48D17●                | 50                  |
| ATS 48D22● to ATS 48D47●  | 40                  |
| ATS 48D62● to ATS 48C79●  | 50                  |
| ATS 48M10● and ATS 48M12● | 85                  |

# Soft starters

Altistart 48 soft start - soft stop units

440 V power supply

Type 1 coordination

## Components for use together in accordance with standards IEC 60947-4-1 and IEC 60947-4-2 (see schemes on pages 60524/2 to 60524/7)

Combine either circuit-breaker (light blue columns), contactor, starter, or switches/fuses (dark blue columns), contactor, starter

| Motor<br>kW | A    | Starter                           |                                 | Type of circuit-breaker              |             | Type of contactor | Type of switch or switch disconnector (bare unit) | Am fuses                     |              | Size    | Rating<br>A |
|-------------|------|-----------------------------------|---------------------------------|--------------------------------------|-------------|-------------------|---|------------------------------|--------------|---------|-------------|
|             |      | Class 10<br>Standard applications | Class 20<br>Severe applications | Telemecanique<br><i>Merlin Gerin</i> | Rating<br>A |                   |   | Reference<br>Without striker | With striker |         |             |
| M1          |      | A1                                |                                 | Q1                                   |             | KM1, KM2, KM3     |   |                              |              |         |             |
| 5.5         | 10.4 | -                                 | ATS 48D17Y                      | NS100● MA (1)<br>NS80H MA            | 12.5        | LC1 D12           | LS1 D32   | DF2 CA16                     | -            | 10 x 38 | 16          |
| 7.5         | 13.7 | ATS 48D17Y                        | ATS 48D22Y                      | NS100● MA (1)<br>NS80H MA            | 25          | LC1 D18           | LS1 D32   | DF2 CA16                     | -            | 10 x 38 | 16          |
| 11          | 20.1 | ATS 48D22Y                        | ATS 48D32Y                      | NS100● MA (1)<br>NS80H MA            | 25          | LC1 D25           | GK1 EK  | DF2 EA25                     | DF3 EA25     | 14 x 51 | 25          |
| 15          | 26.5 | ATS 48D32Y                        | ATS 48D38Y                      | NS100● MA (1)<br>NS80H MA            | 50          | LC1 D32           | GK1 EK  | DF2 EA32                     | DF3 EA32     | 14 x 51 | 32          |
| 18.5        | 32.8 | ATS 48D38Y                        | ATS 48D47Y                      | NS100● MA (1)<br>NS80H MA            | 50          | LC1 D40           | GK1 EK  | DF2 EA40                     | DF3 EA40     | 14 x 51 | 40          |
| 22          | 39   | ATS 48D47Y                        | ATS 48D62Y                      | NS100● MA (1)<br>NS80H MA            | 50          | LC1 D40           | GK1 FK  | DF2 FA50                     | DF3 FA50     | 22 x 58 | 50          |
| 30          | 52   | ATS 48D62Y                        | ATS 48D75Y                      | NS80H MA                             | 80          | LC1 D65           | GK1 FK  | DF2 FA80                     | DF3 FA80     | 22 x 58 | 80          |
| 37          | 64   | ATS 48D75Y                        | ATS 48D88Y                      | NS80H MA                             | 80          | LC1 D65           | GK1 FK  | DF2 FA80                     | DF3 FA80     | 22 x 58 | 80          |
| 45          | 76   | ATS 48D88Y                        | ATS 48C11Y                      | NS100● MA (1)                        | 100         | LC1 D115          | GK1 FK  | DF2 FA100                    | DF3 FA100    | 22 x 58 | 100         |
| 55          | 90   | ATS 48C11Y                        | ATS 48C14Y                      | NS100● MA (1)                        | 100         | LC1 D115          | GS1 L   | DF2 GA1121                   | DF4 GA1121   | 0       | 125         |
| 75          | 125  | ATS 48C14Y                        | ATS 48C17Y                      | NS160● MA (1)                        | 150         | LC1 D150          | GS1 L   | DF2 GA1161                   | DF4 GA1161   | 1       | 160         |
| 90          | 150  | ATS 48C17Y                        | ATS 48C21Y                      | NS250● MA (1)                        | 220         | LC1 F185          | GS1 N   | DF2 HA1201                   | DF4 HA1201   | 1       | 200         |
| 110         | 178  | ATS 48C21Y                        | ATS 48C25Y                      | NS250● MA (1)                        | 220         | LC1 F225          | GS1 N   | DF2 HA1251                   | DF4 HA1251   | 1       | 250         |
| 132         | 215  | ATS 48C25Y                        | ATS 48C32Y                      | NS250● MA (1)                        | 220         | LC1 F265          | GS1 QQ  | DF2 JA1311                   | DF4 JA1311   | 2       | 315         |
| 160         | 256  | ATS 48C32Y                        | ATS 48C41Y                      | NS400● MA (1)                        | 320         | LC1 F265          | GS1 QQ  | DF2 JA1401                   | DF4 JA1401   | 2       | 315         |
| 220         | 353  | ATS 48C41Y                        | ATS 48C48Y                      | NS630● MA (1)                        | 500         | LC1 F400          | GS1 S   | DF2 KA1501                   | DF4 KA1501   | 3       | 500         |
| 250         | 401  | ATS 48C48Y                        | ATS 48C59Y                      | NS630● MA (1)                        | 500         | LC1 F400          | GS1 S   | DF2 KA1501                   | DF4 KA1501   | 3       | 500         |
| 355         | 549  | ATS 48C59Y                        | ATS 48C66Y                      | NS630b● (1)<br>Micrologic 5.0        | 630         | LC1 F630          | GS1 V   | DF2 LA1801                   | DF4 LA1801   | 4       | 800         |
| 400         | 611  | ATS 48C66Y                        | ATS 48C79Y                      | NS630b● (1)<br>Micrologic 5.0        | 630         | LC1 F630          | GS1 V   | DF2 LA1801                   | DF4 LA1801   | 4       | 800         |
| 500         | 780  | ATS 48C79Y                        | ATS 48M10Y                      | NS800● (1)<br>Micrologic 5.0         | 800         | LC1 BM33          | GS1 V   | DF2 LA1801                   | DF4 LA1801   | 4       | 800         |
|             |      |                                   |                                 | C801● (1)<br>STR35ME                 | 800         | LC1 BM33          | GS1 V   | DF2 LA1801                   | DF4 LA1801   | 4       | 800         |
| 630         | 965  | ATS 48M10Y                        | ATS 48M12Y                      | NS1000● (1)<br>Micrologic 5.0        | 1000        | LC1 BP33          | GS1 V   | DF2 LA1101                   | DF4 LA1101   | 4       | 1000        |
|             |      |                                   |                                 | C1001L<br>STR35ME                    | 1000        | LC1 BP33          | GS1 V   | DF2 LA1101                   | DF4 LA1101   | 4       | 1000        |
| 710         | 1075 | ATS 48M12Y                        | -                               | NS1250● (1)<br>Micrologic 5.0        | 1250        | LC1 BP33          | -   | DF2 LA1251                   | -            | 4       | 1250        |
|             |      |                                   |                                 | C1251● (1)<br>STR35ME                | 1250        | LC1 BP33          | -   | DF2 LA1251                   | -            | 4       | 1250        |

(1) Replace ● with N, H or L, according to the breaking capacity (see table below).

### Breaking capacity of circuit-breakers according to standard IEC 60947-2

| 440 V                     | Icu (kA)  |
|---------------------------|-----------|
| GV2 L20, GV2 L22, GV2 L32 | 20        |
| GK3 EF40                  | 30        |
| GK3 EF65, GK3 EF80        | 25        |
| NS80                      | 65        |
| 440 V                     | Icu (kA)  |
|                           | N H L     |
| NS100                     | 25 65 130 |
| NS160, NS250              | 35 65 130 |
| NS400, NS630              | 42 65 130 |
| NS800, NS1000             | 50 65 130 |
| NS1250                    | 50 65 -   |
| C801, C1001               | 42 65 150 |
| C1251                     | 42 65 -   |

### Maximum prospective short-circuit current of the starter according to standard IEC 60947-4-2

| Starter                   | Iq (kA) |
|---------------------------|---------|
| ATS 48D17Y and ATS 48C32Y | 50      |
| ATS 48C41Y to ATS 48M12Y  | 70      |

## Soft starters

Altistart 48 soft start - soft stop units

440 V power supply

Type 2 coordination

### Components for use together in accordance with standards IEC 60947-4-1 and IEC 60947-4-2 (see schemes on pages 60524/2 to 60524/7) circuit-breakers, contactors, fast-acting fuses, starters

Combination: circuit-breaker, contactor, starter

| Motor |      | Starter               |                     | Type of circuit-breaker       | Rating | Type of contactor |
|-------|------|-----------------------|---------------------|-------------------------------|--------|-------------------|
| kW    | A    | Class 10              | Class 20            | Telemecanique<br>Merlin Gerin | A      |                   |
|       |      | Standard applications | Severe applications |                               |        |                   |
| M1    |      | A1                    |                     | Q1                            |        | KM1, KM2, KM3     |
| 5.5   | 10.4 | -                     | ATS 48D17Y          | NS80H-MA                      | 12.5   | LC1 D40           |
|       |      |                       |                     | NS100 MA (1)                  | 12.5   | LC1 D80           |
| 7.5   | 13.7 | ATS 48D17Y            | ATS 48D22Y          | NS80H-MA                      | 25     | LC1 D40           |
|       |      |                       |                     | NS100 MA (1)                  | 25     | LC1 D80           |
| 11    | 20.1 | ATS 48D22Y            | ATS 48D32Y          | NS80H-MA                      | 25     | LC1 D40           |
|       |      |                       |                     | NS100 MA (1)                  | 25     | LC1 D80           |
| 15    | 26.5 | ATS 48D32Y            | ATS 48D38Y          | NS100 MA (1) NS80H-MA         | 50     | LC1 D80           |
| 18.5  | 32.8 | ATS 48D38Y            | ATS 48D47Y          | NS100 MA (1) NS80H MA         | 50     | LC1 D80           |
| 22    | 39   | ATS 48D47Y            | ATS 48D62Y          | NS100 MA (1) NS80H MA         | 50     | LC1 D80           |
| 30    | 52   | ATS 48D62Y            | ATS 48D75Y          | NS100 MA (1)                  | 100    | LC1 D80           |
|       |      |                       |                     | NS80H MA                      | 80     | LC1 D80           |
| 37    | 64   | ATS 48D75Y            | ATS 48D88Y          | NS100 MA (1)                  | 100    | LC1 D80           |
|       |      |                       |                     | NS80H MA                      | 80     | LC1 D80           |
| 45    | 76   | ATS 48D88Y            | ATS 48C11Y          | NS100 MA (1)                  | 100    | LC1 D115          |
| 55    | 90   | ATS 48C11Y            | ATS 48C14Y          | NS100 MA (1)                  | 100    | LC1 D115          |
| 75    | 125  | ATS 48C14Y            | ATS 48C17Y          | NS160 MA (1)                  | 150    | LC1 D150          |
| 90    | 150  | ATS 48C17Y            | ATS 48C21Y          | NS160 MA (1)                  | 150    | LC1 D150          |
| 110   | 178  | ATS 48C21Y            | ATS 48C25Y          | NS250 MA (1)                  | 220    | LC1 F185          |
| 132   | 215  | ATS 48C25Y            | ATS 48C32Y          | NS400 MA (1)                  | 320    | LC1 F265          |
| 160   | 256  | ATS 48C32Y            | ATS 48C41Y          | NS400 MA (1)                  | 320    | LC1 F265          |
| 220   | 353  | ATS 48C41Y            | ATS 48C48Y          | NS630 MA (1)                  | 500    | LC1 F400          |
| 250   | 401  | ATS 48C48Y            | ATS 48C59Y          | NS630 MA (1)                  | 500    | LC1 F500          |
| 355   | 549  | ATS 48C59Y            | ATS 48C66Y          | NS630bL Micrologic 5.0        | 630    | LC1 F630          |
| 400   | 611  | ATS 48C66Y            | ATS 48C79Y          | NS800L Micrologic 5.0         | 800    | LC1 F800          |
| 500   | 780  | ATS 48C79Y            | ATS 48M10Y          | NS800L Micrologic 5.0         | 800    | LC1 F800          |
| 630   | 965  | ATS 48M10Y            | ATS 48M12Y          | NS1000L Micrologic 5.0        | 1000   | LC1 BP33          |
| 710   | 1075 | ATS 48M12Y            | -                   | NS1250 (1) Micrologic 5.0 (2) | 1250   | LC1 BP33          |

(1) Replace ● with N, H or L, according to the breaking capacity (see the breaking capacity table on the previous page).

(2) Type 2 coordination is only possible if the fast-acting fuses remain in the motor supply circuit and are not bypassed at the end of starting.

#### Fast-acting fuse (essential for type 2 coordination), starter combinations

| Starter Reference         | Fast-acting fuses Reference | Size    | Rating A | I <sub>t</sub> kA <sup>2</sup> .s |
|---------------------------|-----------------------------|---------|----------|-----------------------------------|
| A1                        | Q3                          |         |          |                                   |
| ATS 48D17Y                | DF3 ER50                    | 14 x 51 | 50       | 2.3                               |
| ATS 48D22Y and ATS 48D32Y | DF3 FR80                    | 22 x 58 | 80       | 5.6                               |
| ATS 48D38Y and ATS 48D47Y | DF3 FR100                   | 22 x 58 | 100      | 12                                |
| ATS 48D62Y and ATS 48D75Y | DF4 00125                   | 00      | 125      | 45                                |
| ATS 48D88Y and ATS 48C11Y | DF4 00160                   | 00      | 160      | 82                                |
| ATS 48C14Y and ATS 48C17Y | DF4 30400                   | 30      | 400      | 120                               |
| ATS 48C21Y to ATS 48C32Y  | DF4 31700                   | 31      | 700      | 490                               |
| ATS 48C41Y                | DF4 33800                   | 33      | 800      | 490                               |
| ATS 48C48Y and ATS 48C59Y | DF4 331000                  | 33      | 1000     | 900                               |
| ATS 48C66Y                | DF4 2331400                 | 2 x 33  | 1400     | 1200                              |
| ATS 48C79Y                | DF4 441600                  | 44      | 1600     | 1600                              |
| ATS 48M10Y and ATS 48M12Y | DF4 442200                  | 44      | 2200     | 4100                              |

#### Maximum prospective short-circuit current of the starter according to standard IEC 60947-4-2

| Starter                   | I <sub>q</sub> (kA) |
|---------------------------|---------------------|
| ATS 48D17Y                | 50                  |
| ATS 48D22Y to ATS 48D47Y  | 20                  |
| ATS 48D62Y and ATS 48D75Y | 50                  |
| ATS 48D88Y                | 40                  |
| ATS 48C11Y to ATS 48C32Y  | 50                  |
| ATS 48C41Y                | 40                  |
| ATS 48C48Y to ATS 48C79Y  | 50                  |
| ATS 48M10Y and ATS 48M12Y | 85                  |

# Soft starters

Altistart 48 soft start - soft stop units

500 V power supply

Type 1 coordination

## Components for use together in accordance with standards IEC 60947-4-1 and IEC 60947-4-2 (see schemes on pages 60524/2 to 60524/7)

Combine either circuit-breaker (light blue columns), contactor, starter, or switches/fuses (dark blue columns), contactor, starter

| Motor<br>kW | A    | Starter                           |                                 | Type of circuit-breaker         |             | Type of contactor | Type of switch or switch disconnecter (bare unit) | Am fuses                     |              | Size    | Rating<br>A |
|-------------|------|-----------------------------------|---------------------------------|---------------------------------|-------------|-------------------|---|------------------------------|--------------|---------|-------------|
|             |      | Class 10<br>Standard applications | Class 20<br>Severe applications | Telemecanique<br>Merlin Gerin   | Rating<br>A |                   |   | Reference<br>Without striker | With striker |         |             |
| M1          |      | A1                                |                                 | Q1                              |             | KM1, KM2, KM3     |   |                              |              |         |             |
| 7.5         | 12   | –                                 | ATS 48D17Y                      | NS100● MA (1)<br>NS80H MA       | 12.5        | LC1 D12           | LS1 D32   | DF2 CA16                     | –            | 10 x 38 | 16          |
| 9           | 14   | ATS 48D17Y                        | ATS 48D22Y                      | NS100● MA (1)<br>NS80H MA       | 25          | LC1 D18           | LS1 D32   | DF2 CA16                     | –            | 10 x 38 | 16          |
| 11          | 18.4 | ATS 48D22Y                        | ATS 48D32Y                      | NS100● MA (1)<br>NS80H MA       | 25          | LC1 D25           | GK1 EK  | DF2 EA25                     | DF3 EA25     | 14 x 51 | 25          |
| 18.5        | 28.5 | ATS 48D32Y                        | ATS 48D38Y                      | NS100● MA (1)<br>NS80H MA       | 50          | LC1 D32           | GK1 EK  | DF2EA32                      | DF3 EA32     | 14 x 51 | 32          |
| 22          | 33   | ATS 48D38Y                        | ATS 48D47Y                      | NS100● MA (1)<br>NS80H MA       | 50          | LC1 D40           | GK1 EK  | DF2 EA40                     | DF3 EA40     | 14 x 51 | 40          |
| 30          | 45   | ATS 48D47Y                        | ATS 48D62Y                      | NS100● MA (1)<br>NS80H MA       | 50          | LC1 D50           | GK1 FK  | DF2 FA50                     | DF3 FA50     | 22 x 58 | 50          |
| 37          | 55   | ATS 48D62Y                        | ATS 48D75Y                      | NS100● MA (1)                   | 100         | LC1 D65           | GK1 FK  | DF2 FA80                     | DF3 FA80     | 22 x 58 | 80          |
| 45          | 65   | ATS 48D75Y                        | ATS 48D88Y                      | NS100● MA (1)                   | 100         | LC1 D80           | GK1 FK  | DF2 FA80                     | DF3 FA80     | 22 x 58 | 80          |
| 55          | 80   | ATS 48D88Y                        | ATS 48C11Y                      | NS100● MA (1)                   | 100         | LC1 D80           | GK1 FK  | DF2 FA100                    | DF3 FA100    | 22 x 58 | 100         |
| 75          | 105  | ATS 48C11Y                        | ATS 48C14Y                      | NS160● MA (1)                   | 150         | LC1 D115          | GS1 L   | DF2 GA1121                   | DF4 GA1121   | 0       | 125         |
| 90          | 130  | ATS 48C14Y                        | ATS 48C17Y                      | NS160● MA (1)                   | 150         | LC1 D150          | GS1 L   | DF2 GA1161                   | DF4 GA1161   | 0       | 160         |
| 110         | 156  | ATS 48C17Y                        | ATS 48C21Y                      | NS250● MA (1)                   | 220         | LC1 F185          | GS1 N   | DF2 HA1201                   | DF4 HA1201   | 1       | 200         |
| 132         | 207  | ATS 48C21Y                        | ATS 48C25Y                      | NS250● MA (1)                   | 220         | LC1 F265          | GS1 N   | DF2 HA1251                   | DF4HA1251    | 1       | 250         |
| 160         | 257  | ATS 48C25Y                        | ATS 48C32Y                      | NS400● MA (1)                   | 320         | LC1 F265          | GS1 QQ  | DF2 JA1311                   | DF4 JA1311   | 2       | 315         |
| 220         | 310  | ATS 48C32Y                        | ATS 48C41Y                      | NS630● MA (1)                   | 500         | LC1 F400          | GS1 QQ  | DF2 JA1401                   | DF4 JA1401   | 2       | 400         |
| 250         | 360  | ATS 48C41Y                        | ATS 48C48Y                      | NS630● MA (1)                   | 500         | LC1 F400          | GS1 S   | DF2 KA1501                   | DF4 KA1501   | 3       | 500         |
| 315         | 460  | ATS 48C48Y                        | ATS 48C59Y                      | NS630● MA (1)                   | 500         | LC1 F500          | GS1 S   | DF2 KA1631                   | DF4 KA1631   | 3       | 630         |
| 400         | 540  | ATS 48C59Y                        | ATS 48C66Y                      | NS630● (1)<br>Micrologic 5.0    | 630         | LC1 F630          | GS1 V   | DF2 LA1801                   | DF4 LA1801   | 4       | 800         |
| 450         | 630  | ATS 48C66Y                        | ATS 48C79Y                      | NS630● (1)<br>Micrologic 5.0    | 630         | LC1 F800          | GS1 V   | DF2 LA1801                   | DF4 LA1801   | 4       | 800         |
| 500         | 680  | ATS 48C79Y                        | ATS 48M10Y                      | NS800● MA (1)<br>Micrologic 5.0 | 800         | LC1 BL33          | GS1 V   | DF2 LA1801                   | DF4 LA1801   | 4       | 800         |
|             |      |                                   |                                 | C1001● (1)<br>STR35 ME          | 1000        | LC1 BL33          | GS1 V   | DF2 LA1801                   | DF4 LA1801   | 4       | 800         |
| 630         | 850  | ATS 48M10Y                        | ATS 48M12Y                      | NS1000● (1)<br>Micrologic 5.0   | 1000        | LC1 BP33          | GS1 V   | DF2 LA1101                   | DF4 LA1101   | 4       | 1000        |
|             |      |                                   |                                 | C1001● (1)<br>STR35 ME          | 1000        | LC1 BP33          | GS1 V   | DF2 LA1101                   | DF4 LA1101   | 4       | 1000        |
| 800         | 1100 | ATS 48M12Y                        | –                               | NS1250● (1)<br>Micrologic 5.0   | 1250        | LC1 BP33          | –   | DF2 LA1251                   | –            | 4       | 1250        |
|             |      |                                   |                                 | C1251● (1)<br>STR35 ME          | 1250        | LC1 BP33          | –   | DF2 LA1251                   | –            | 4       | 1250        |

(3) Replace ● with N, H or L, according to the breaking capacity (see table below).

### Breaking capacity of circuit-breakers according to standard IEC 60947-2

| 500 V                     | Icu (kA)  |
|---------------------------|-----------|
| GV2 L20, GV2 L22, GV2 L32 | 10        |
| GK3 EF40                  | 20        |
| GK3 EF65, GK3 EF80        | 15        |
| NS80                      | 25        |
| 500 V                     | Icu (kA)  |
|                           | N H L     |
| NS100                     | 18 50 100 |
| NS160, NS250, NS630       | 30 50 70  |
| NS400                     | 30 50 100 |
| NS800, NS1000             | 40 50 100 |
| NS1250                    | 40 50 –   |
| C801, C1001               | 40 50 100 |
| C1251                     | 40 50 –   |

### Maximum prospective short-circuit current of the starter according to standard IEC 60947-4-2

| Starter                  | Iq (kA) |
|--------------------------|---------|
| ATS 48D17Y to ATS 48C32Y | 50      |
| ATS 48C41Y to ATS 48M12Y | 70      |

## Soft starters

Altistart 48 soft start - soft stop units

500 V power supply

Type 2 coordination

### Components for use together in accordance with standards IEC 60947-4-1 and IEC 60947-4-2 (see schemes on pages 60524/2 to 60524/7) circuit-breakers, contactors, fast-acting fuses, starters

Combination: circuit-breaker, contactor, starter

| Motor |      | Starter                           |                                 | Type of circuit-breaker              | Rating<br>A  | Type of contactor  |
|-------|------|-----------------------------------|---------------------------------|--------------------------------------|--------------|--------------------|
| kW    | A    | Class 10<br>Standard applications | Class 20<br>Severe applications | Telemecanique<br><i>Merlin Gerin</i> |              |                    |
| M1    |      | A1                                |                                 | Q1                                   |              | KM1, KM2, KM3      |
| 7.5   | 12   | –                                 | ATS 48D17Y                      | NS80H MA<br>NS100● MA (1)            | 12.5<br>12.5 | LC1 D40<br>LC1 D80 |
| 9     | 14   | ATS 48D17Y                        | ATS 48D22Y                      | NS80H MA<br>NS100● MA (1)            | 25<br>25     | LC1 D40<br>LC1 D80 |
| 11    | 18.4 | ATS 48D22Y                        | ATS 48D32Y                      | NS80H MA<br>NS100● MA (1)            | 25<br>25     | LC1 D40<br>LC1 D80 |
| 18.5  | 28.5 | ATS 48D32Y                        | ATS 48D38Y                      | NS100● MA (1) NS80H MA               | 50           | LC1 D80            |
| 22    | 33   | ATS 48D38Y                        | ATS 48D47Y                      | NS100● MA (1) NS80H MA               | 50           | LC1 D80            |
| 30    | 45   | ATS 48D47Y                        | ATS 48D62Y                      | NS100● MA (1) NS80H MA               | 50           | LC1 D80            |
| 37    | 55   | ATS 48D62Y                        | ATS 48D75Y                      | NS100● MA (1)                        | 100          | LC1 D80            |
| 45    | 65   | ATS 48D75Y                        | ATS 48D88Y                      | NS100● MA (1)                        | 100          | LC1 D80            |
| 55    | 80   | ATS 48D88Y                        | ATS 48C11Y                      | NS100● MA (1)                        | 100          | LC1 D115           |
| 75    | 105  | ATS 48C11Y                        | ATS 48C14Y                      | NS160● MA (1)                        | 150          | LC1 D115           |
| 90    | 130  | ATS 48C14Y                        | ATS 48C17Y                      | NS160● MA (1)                        | 150          | LC1 D150           |
| 110   | 156  | ATS 48C17Y                        | ATS 48C21Y                      | NS250● MA (1)                        | 220          | LC1 F185           |
| 132   | 207  | ATS 48C21Y                        | ATS 48C25Y                      | NS250● MA (1)                        | 220          | LC1 F265           |
| 160   | 257  | ATS 48C25Y                        | ATS 48C32Y                      | NS400● MA (1)                        | 320          | LC1 F400           |
| 220   | 310  | ATS 48C32Y                        | ATS 48C41Y                      | NS400● MA (1)                        | 320          | LC1 F400           |
| 250   | 360  | ATS 48C41Y                        | ATS 48C48Y                      | NS630● MA (1)                        | 500          | LC1 F500           |
| 315   | 460  | ATS 48C48Y                        | ATS 48C59Y                      | NS630● MA (1)                        | 500          | LC1 F500           |
| 400   | 540  | ATS 48C59Y                        | ATS 48C66Y                      | NS630bL Micrologic 5.0               | 630          | LC1 F630           |
| 450   | 630  | ATS 48C66Y                        | ATS 48C79Y                      | NS630bL Micrologic 5.0               | 630          | LC1 F800           |
| 500   | 680  | ATS 48C79Y                        | ATS 48M10Y                      | NS800L Micrologic 5.0                | 800          | LC1 BL33           |
| 630   | 850  | ATS 48M10Y                        | ATS 48M12Y                      | NS1000L Micrologic 5.0               | 1000         | LC1 BP33           |
| 800   | 1100 | ATS 48M12Y                        | –                               | NS1250● (1) Micrologic 5.0 (2)       | 1250         | LC1 BP33           |

(1) Replace ● with N, H or L, according to the breaking capacity (see the breaking capacity table on the previous page).

(2) Type 2 coordination is only possible if the fast-acting fuses remain in the motor supply circuit and are not bypassed at the end of starting.

#### Fast-acting fuse (essential for type 2 coordination), starter combinations

| Starter<br>Reference      | Fast-acting fuses |         |             |  |
|---------------------------|-------------------|---------|-------------|--|
|                           | Reference         | Size    | Rating<br>A | I <sup>2</sup> t<br>kA <sup>2</sup> .s |
| A1                        | Q3                |         |             |  |
| ATS 48D17Y                | DF3 ER50          | 14 x 51 | 50          | 2.3                                    |
| ATS 48D22Y and ATS 48D32Y | DF3 FR80          | 22 x 58 | 80          | 5.6                                    |
| ATS 48D38Y and ATS 48D47Y | DF3 FR100         | 22 x 58 | 100         | 12                                     |
| ATS 48D62Y and ATS 48D75Y | DF4 00125         | 00      | 125         | 45                                     |
| ATS 48D88Y and ATS 48C11Y | DF4 00160         | 00      | 160         | 82                                     |
| ATS 48C14Y and ATS 48C17Y | DF4 30400         | 30      | 400         | 120                                    |
| ATS 48C21Y to ATS 48C32Y  | DF4 31700         | 31      | 700         | 490                                    |
| ATS 48C41Y                | DF4 33800         | 33      | 800         | 490                                    |
| ATS 48C48Y and ATS 48C59Y | DF4 331000        | 33      | 1000        | 900                                    |
| ATS 48C66Y                | DF4 2331400       | 2 x 33  | 1400        | 1200                                   |
| ATS 48C79Y                | DF4 441600        | 44      | 1600        | 1600                                   |
| ATS 48M10Y and ATS 48M12Y | DF4 442200        | 44      | 2200        | 4100                                   |

#### Maximum prospective short-circuit current of the starter according to standard IEC 60947-4-2

| Starter                   | Iq (kA) |
|---------------------------|---------|
| ATS 48D17Y                | 50      |
| ATS 48D22Y to ATS 48D47Y  | 20      |
| ATS 48D62Y and ATS 48D75Y | 50      |
| ATS 48D88Y                | 40      |
| ATS 48C11Y to ATS 48C32Y  | 50      |
| ATS 48C41Y                | 40      |
| ATS 48C48Y to ATS 48C79Y  | 50      |
| ATS 48M10Y and ATS 48M12Y | 85      |

# Soft starters

Altistart 48 soft start - soft stop units

690 V power supply

Type 1 coordination

**Components for use together in accordance with standards IEC 60947-4-1 and IEC 60947-4-2 (see schemes on pages 60524/2 to 60524/7)**

Combine either circuit-breaker (light blue columns), contactor, starter, or switches/fuses (dark blue columns), contactor, starter

| Motor<br>kW | A    | Starter                           |                                 | Type of circuit-breaker        |              | Type of contactor | Type of switch or switch disconnecter (bare unit) | Am fuses                     |              | Size    | Rating<br>A |
|-------------|------|-----------------------------------|---------------------------------|--------------------------------|--------------|-------------------|---|------------------------------|--------------|---------|-------------|
|             |      | Class 10<br>Standard applications | Class 20<br>Severe applications | Telemechanique<br>Merlin Gerin | Rating<br>A  |                   |   | Reference<br>Without striker | With striker |         |             |
| M1          |      | A1                                |                                 | Q1                             |              | KM1, KM2, KM3     |   |                              |              |         |             |
| 11          | 12.1 | –                                 | ATS 48D17Y                      | NS100● MA (1)<br>NS80H MA      | 12.5<br>12.5 | LC1 D18           | GK1 FK  | DF2 FA16                     | DF3 FA16     | 22 x 58 | 16          |
| 15          | 16.5 | ATS 48D17Y                        | ATS 48D22Y                      | NS100● MA (1)<br>NS80H MA      | 25<br>25     | LC1 D25           | GK1 FK  | DF2 FA20                     | DF3 FA20     | 22 x 58 | 20          |
| 18.5        | 20.2 | ATS 48D22Y                        | ATS 48D32Y                      | NS100● MA (1)<br>NS80H MA      | 50<br>50     | LC1 D32           | GK1 FK  | DF2 FA25                     | DF3 FA25     | 22 x 58 | 25          |
| 22          | 24.2 | ATS 48D32Y                        | ATS 48D38Y                      | NS100● MA (1)<br>NS80H MA      | 50<br>50     | LC1 D40           | GK1 FK  | DF2 FA32                     | DF3 FA32     | 22 x 58 | 32          |
| 30          | 33   | ATS 48D38Y                        | ATS 48D47Y                      | NS100● MA (1)<br>NS80H MA      | 50<br>50     | LC1 D40           | GK1 FK  | DF2 FA40                     | DF3 FA40     | 22 x 58 | 40          |
| 37          | 40   | ATS 48D47Y                        | ATS 48D62Y                      | NS100● MA (1)<br>NS80H MA      | 50<br>50     | LC1 D65           | GK1 FK  | DF2 FA50                     | DF3 FA50     | 22 x 58 | 50          |
| 45          | 49   | ATS 48D62Y                        | ATS 48D75Y                      | NS100● MA (1)                  | 100          | LC1 D80           | –   | –                            | –            | –       | –           |
| 55          | 58   | ATS 48D75Y                        | ATS 48D88Y                      | NS100● MA (1)                  | 100          | LC1D-115          | –   | –                            | –            | –       | –           |
| 75          | 75.5 | ATS 48D88Y                        | ATS 48C11Y                      | NS100● MA (1)                  | 100          | LC1D-115          | –   | –                            | –            | –       | –           |
| 90          | 94   | ATS 48C11Y                        | ATS 48C14Y                      | NS160● MA (1)                  | 150          | LC1D-150          | –   | –                            | –            | –       | –           |
| 110         | 113  | ATS 48C14Y                        | ATS 48C17Y                      | NS160● MA (1)                  | 150          | LC1D-150          | –   | –                            | –            | –       | –           |
| 160         | 165  | ATS 48C17Y                        | ATS 48C21Y                      | NS250● MA (1)                  | 220          | LC1F-265          | –   | –                            | –            | –       | –           |
| 200         | 203  | ATS 48C21Y                        | ATS 48C25Y                      | NS400● MA (1)                  | 320          | LC1F-330          | –   | –                            | –            | –       | –           |
| 250         | 253  | ATS 48C25Y                        | ATS 48C32Y                      | NS400● MA (1)                  | 320          | LC1F-400          | –   | –                            | –            | –       | –           |
| 315         | 321  | ATS 48C32Y                        | ATS 48C41Y                      | NS630● MA (1)                  | 500          | LC1F-500          | –   | –                            | –            | –       | –           |
| 400         | 390  | ATS 48C41Y                        | ATS 48C48Y                      | NS630● MA (1)                  | 500          | LC1 F630          | –   | –                            | –            | –       | –           |
| 500         | 490  | ATS 48C48Y                        | ATS 48C59Y                      | NS630b● (1)<br>Micrologic 5.0  | 630          | LC1 BL33          | –   | –                            | –            | –       | –           |
|             |      |                                   |                                 | C801● (1)<br>STR35 ME          | 800          | LC1 BL33          | –   | –                            | –            | –       | –           |
| 560         | 549  | ATS 48C59Y                        | ATS 48C66Y                      | NS630b● (1)<br>Micrologic 5.0  | 630          | LC1 BL33          | –   | –                            | –            | –       | –           |
|             |      |                                   |                                 | C801● (1)<br>STR35 ME          | 800          | LC1 BL33          | –   | –                            | –            | –       | –           |
| 630         | 605  | ATS 48C66Y                        | ATS 48C79Y                      | NS800● (1)<br>Micrologic 5.0   | 800          | LC1 BP33          | –   | –                            | –            | –       | –           |
|             |      |                                   |                                 | C801● (1)<br>STR35 ME          | 800          | LC1 BP33          | –   | –                            | –            | –       | –           |
| 710         | 694  | ATS 48C79Y                        | ATS 48M10Y                      | NS800● (1)<br>Micrologic 5.0   | 800          | LC1 BP33          | –   | –                            | –            | –       | –           |
|             |      |                                   |                                 | C801● (1)<br>STR35 ME          | 800          | LC1 BP33          | –   | –                            | –            | –       | –           |
| 900         | 880  | ATS 48M10Y                        | ATS 48M12Y                      | NS1000● (1)<br>Micrologic 5.0  | 1000         | LC1 BR33          | –   | –                            | –            | –       | –           |
|             |      |                                   |                                 | C1001L<br>STR35 ME             | 1000         | LC1 BR33          | –   | –                            | –            | –       | –           |
| 950         | 1000 | ATS 48M12Y                        | –                               | NS1250● (1)<br>Micrologic 5.0  | 1250         | LC1 BR33          | –   | –                            | –            | –       | –           |
|             |      |                                   |                                 | C1251● (1)<br>STR35 ME         | 1250         | LC1 BR33          | –   | –                            | –            | –       | –           |

(1) Replace ● with N, H or L, according to the breaking capacity (see table below).

| Maximum prospective short-circuit current of the starter according to standard IEC 60947-4-2 |         | Breaking capacity of circuit-breakers according to standard IEC 60947-2 |    |    |    |
|--|---------|---|----|----|----|
| Starter  | Iq (kA) | 690 V   |    |    |    |
| ATS 48D17Y and ATS 48C32Y  | 50      | GV2 L20, GV2 L22, GV2 L32   |    |    |    |
| ATS 48C41Y to ATS 48M12Y   | 70      | GK3 EF40, GK3 EF65, GK3 EF80, NS80                                      |    |    |    |
|  |         | 690 V   |    |    |    |
|  |         | Icu (kA)  |    |    |    |
|  |         | N   | H  | L  |    |
|  |         | NS100   | 8  | 10 | 75 |
|  |         | NS160, NS250  | 8  | 10 | 20 |
|  |         | NS400   | 10 | 20 | 75 |
|  |         | NS630   | 10 | 20 | 35 |
|  |         | NS800, NS1000   | 30 | 42 | 25 |
|  |         | NS1250  | 30 | 42 | –  |
|  |         | C801, C1001   | 25 | 40 | 60 |
|  |         | C1251   | 25 | 40 | –  |

## Soft starters

Altistart 48 soft start - soft stop units

690 V power supply

Type 2 coordination

### Components for use together in accordance with standards IEC 60947-4-1 and IEC 60947-4-2 (see schemes on pages 60524/2 to 60524/7) circuit-breakers, contactors, fast-acting fuses, starters

Combination: circuit-breaker, contactor, starter

| Motor |      | Starter                           |                                 | Type of circuit-breaker              | Rating<br>A | Type of contactor |
|-------|------|-----------------------------------|---------------------------------|--------------------------------------|-------------|-------------------|
| kW    | A    | Class 10<br>Standard applications | Class 20<br>Severe applications | Telemecanique<br><i>Merlin Gerin</i> |             | KM1, KM2, KM3     |
| M1    |      | A1                                |                                 | Q1                                   |             |                   |
| 11    | 12.1 | –                                 | ATS 48D17Y                      | NS100● MA (1)                        | 12.5        | LC1 D80           |
| 15    | 16.5 | ATS 48D17Y                        | ATS 48D22Y                      | NS100● MA (1)                        | 25          | LC1 D80           |
| 18.5  | 20.2 | ATS 48D22Y                        | ATS 48D32Y                      | NS100● MA (1)                        | 50          | LC1 D80           |
| 22    | 24.2 | ATS 48D32Y                        | ATS 48D38Y                      | NS100● MA (1)                        | 50          | LC1 D80           |
| 30    | 33   | ATS 48D38Y                        | ATS 48D47Y                      | NS100● MA (1)                        | 50          | LC1 D80           |
| 37    | 40   | ATS 48D47Y                        | ATS 48D62Y                      | NS100● MA (1)                        | 50          | LC1 D80           |
| 45    | 49   | ATS 48D62Y                        | ATS 48D75Y                      | NS100● MA (1)                        | 100         | LC1 D115          |
| 55    | 58   | ATS 48D75Y                        | ATS 48D88Y                      | NS100● MA (1)                        | 100         | LC1 D115          |
| 75    | 75.5 | ATS 48D88Y                        | ATS 48C11Y                      | NS100● MA (1)                        | 100         | LC1 D115          |
| 90    | 94   | ATS 48C11Y                        | ATS 48C14Y                      | NS400● MA (1)                        | 320         | LC1 F265          |
| 110   | 113  | ATS 48C14Y                        | ATS 48C17Y                      | NS400● MA (1)                        | 320         | LC1 F265          |
| 160   | 165  | ATS 48C17Y                        | ATS 48C21Y                      | NS 400● MA (1)                       | 320         | LC1 F265          |
| 200   | 203  | ATS 48C21Y                        | ATS 48C25Y                      | NS400● MA (1)                        | 320         | LC1 F400          |
| 250   | 253  | ATS 48C25Y                        | ATS 48C32Y                      | NS400● MA (1)                        | 320         | LC1 F500          |
| 315   | 321  | ATS 48C32Y                        | ATS 48C41Y                      | NS630● MA (1)                        | 500         | LC1 F500          |
| 400   | 390  | ATS 48C41Y                        | ATS 48C48Y                      | NS630● MA (1)                        | 500         | LC1 F630          |
| 500   | 490  | ATS 48C48Y                        | ATS 48C59Y                      | NS630bL Micrologic 5.0               | 630         | LC1 BL33          |
| 560   | 549  | ATS 48C59Y                        | ATS 48C66Y                      | NS630bL Micrologic 5.0               | 630         | LC1 BL33          |
| 630   | 605  | ATS 48C66Y                        | ATS 48C79Y                      | NS800L Micrologic 5.0                | 800         | LC1 BP33          |
| 710   | 694  | ATS 48C79Y                        | ATS 48M10Y                      | NS800L Micrologic 5.0                | 800         | LC1 BP33          |
| 900   | 880  | ATS 48M10Y                        | ATS 48M12Y                      | NS1000L Micrologic 5.0               | 1000        | LC1 BR33          |
| 950   | 1000 | ATS 48M12Y                        | –                               | NS1250● (1) Micrologic 5.0 (2)       | 1250        | LC1 BR33          |

(1) Replace ● with N, H or L, according to the breaking capacity (see the breaking capacity table on the previous page).

(2) Type 2 coordination is only possible if the fast-acting fuses remain in the motor supply circuit and are not bypassed at the end of starting.

#### Fast-acting fuse (essential for type 2 coordination), starter combinations

| Starter reference         | Fast-acting fuses Reference | Size    | Calibre A | I <sub>t</sub> kA <sup>2</sup> .s |
|---------------------------|-----------------------------|---------|-----------|-----------------------------------|
| A1                        | Q3                          |         |           |                                   |
| ATS 48D17Y                | DF3 ER50                    | 14 x 51 | 50        | 2.3                               |
| ATS 48D22Y and ATS 48D32Y | DF3 FR80                    | 22 x 58 | 80        | 5.6                               |
| ATS 48D38Y and ATS 48D47Y | DF3 FR100                   | 22 x 58 | 100       | 12                                |
| DF3 ER50                  | DF4 00125                   | 00      | 125       | 45                                |
| ATS 48D88Y and ATS 48C11Y | DF4 00160                   | 00      | 160       | 82                                |
| ATS 48C14Y and ATS 48C17Y | DF4 30400                   | 30      | 400       | 120                               |
| ATS 48C21Y to ATS 48C32Y  | DF4 31700                   | 31      | 700       | 490                               |
| ATS 48C41Y                | DF4 33800                   | 33      | 800       | 490                               |
| ATS 48C48Y and ATS 48C59Y | DF4 331000                  | 33      | 1000      | 900                               |
| ATS 48D17Y                | DF4 2331400                 | 2 x 33  | 1400      | 1200                              |
| ATS 48C79Y                | DF4 441600                  | 44      | 1600      | 1600                              |
| ATS 48M10Y and ATS 48M12Y | DF4 442200                  | 44      | 2200      | 4100                              |

Maximum prospective short-circuit current of the starter according to standard IEC 60947-4-2

| Starter                   | I <sub>q</sub> (kA) |
|---------------------------|---------------------|
| ATS 48D17Y                | 50                  |
| ATS 48M10Y and ATS 48M12Y | 15                  |
| ATS 48M10Y and ATS 48M12Y | 20                  |
| ATS 48D62Y and ATS 48D75Y | 50                  |
| ATS 48D88Y                | 20                  |
| ATS 48C11Y to ATS 48C32Y  | 50                  |
| ATS 48C41Y                | 25                  |
| ATS 48C48Y to ATS 48C79Y  | 50                  |
| ATS 48M10Y and ATS 48M12Y | 85                  |

### Summary of functions

|  | See pages        |
|--|------------------|
| <b>Starter factory setting</b>                         | 60526/2          |
| <b>Adjustment functions</b>                            | <b>See pages</b> |
| Nominal motor current (maximum permanent current)      | 60526/3          |
| Limiting current                                       | 60526/3          |
| Acceleration ramp time                                 | 60526/3          |
| Initial starting torque                                | 60526/3          |
| Selection of the type of stop                          | 60526/3          |
| <b>Protection functions</b>                            | <b>See pages</b> |
| Calculated motor thermal protection                    | 60526/4          |
| Reset motor thermal state                              | 60526/4          |
| Motor thermal protection with PTC probes               | 60526/4          |
| Starter thermal protection                             | 60526/4          |
| Motor underload protection                             | 60526/5          |
| Excessive acceleration time protection                 | 60526/5          |
| Current overload protection                            | 60526/5          |
| Protection against line phase inversion                | 60526/5          |
| Time before restarting                                 | 60526/5          |
| Motor phase loss detection                             | 60526/5          |
| Automatic restart                                      | 60526/5          |
| <b>Advanced adjustment functions</b>                   | <b>See pages</b> |
| Torque limit   | 60526/6          |
| Voltage boost level                                    | 60526/6          |
| Connecting the starter to the motor delta terminals    | 60526/6          |
| Test on low power motor                                | 60526/6          |
| Activation of the cascade function                     | 60526/6          |
| Line frequency   | 60526/6          |
| Reset kWh or the operating time                        | 60526/6          |
| Return to factory settings                             | 60526/6          |
| <b>2<sup>nd</sup> motor adjustment functions</b>       | 60526/7          |
| <b>Communication functions</b>                         | 60526/7          |
| <b>PowerSuite advanced dialogue solutions</b>          | 60526/7          |
| <b>Application monitoring functions</b>                | 60526/7          |
| <b>Logic input application functions</b>               | <b>See pages</b> |
| 2-wire/3-wire control                                  | 60526/8          |
| Freewheel stop   | 60526/8          |
| External fault   | 60526/8          |
| Motor preheating                                       | 60526/8          |
| Force to local control mode                            | 60526/8          |
| Inhibit all protection                                 | 60526/8          |
| Reset motor thermal fault                              | 60526/8          |
| Activation of the cascade function                     | 60526/8          |
| Reset all faults                                       | 60526/8          |
| <b>Logic output application functions</b>              | 60526/9          |
| <b>Relay and analogue output application functions</b> | 60526/9          |
| <b>Function compatibility table</b>                    | 60526/9          |

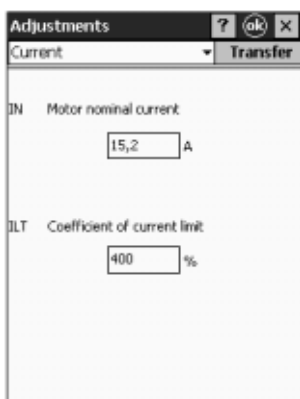

Current setting with PowerSuite on PPC

### Starter factory setting

The starter is supplied ready for use in most applications. The main functions enabled and the default function values are as follows:

- Nominal motor current (depends on the starter rating)
- Limiting current: 400%
- Acceleration ramp time: 15 s
- Initial starting torque: 20%
- Selection of the type of stop: freewheel stop
- Motor thermal protection: class 10
- Time before restarting: 2 s
- Motor phase loss threshold: 10%
- Line frequency: automatic
- RUN and STOP logic inputs: 2-wire or 3-wire control via wiring
- Logic input LI3: forced freewheel stop
- Logic input LI4: local mode control (serial link disabled)
- Logic output LO1: thermal motor alarm
- Logic output LO2: motor powered
- Relay output R1: fault relay
- Relay output R3: motor powered
- Analogue output: motor current

### Adjustment functions

■ **Nominal motor current** (maximum permanent current)

The nominal current of the starter can be adapted to the nominal motor current indicated on the rating plate.

Adjustment range: 0.4 to 1.3 times the starter nominal current.

■ **Limiting current**

The maximum starting current can be adjusted.

Adjustment range: 150% to 700% of the nominal motor current set and limited to 500% of the maximum permanent current defined for the starter rating.

■ **Acceleration ramp time**

During the starting phase, the Altistart 48 applies a torque ramp to the motor. The time (ACC) set corresponds to the time taken by the ramp to reach the nominal torque (starting at 0). Adjustment range: 1 to 60 s.

■ **Initial starting torque**

The initial torque  $tq_0$  applied to the motor can be used to instantly overcome any resistive starting torque. Adjustment range: 0 to 100% of the nominal motor torque.

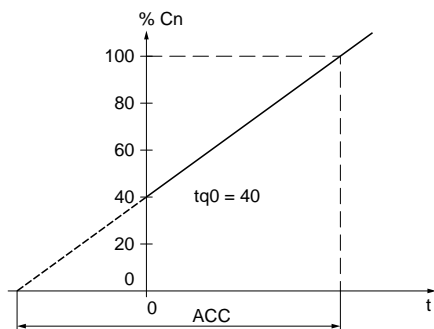

Acceleration ramp during time ACC with initial starting torque  $tq_0 = 40\%$  of the nominal motor torque

■ **Selection of the type of stop**

Three types of stop are available for selection:

□ **Freewheel motor stop**

□ **Motor stop by deceleration via torque control (pump application)** This type of stop enables a centrifugal pump to be decelerated gradually on a ramp in order to avoid a sudden stop. It can be used to dampen the hydraulic transient in order to significantly reduce pressure surges.

The deceleration ramp time (dEC) can be adjusted.

During deceleration, the pump flow rate decreases and becomes negligible at a certain speed. To continue to decelerate would serve no purpose. A torque threshold (EdC) can be set at which the motor will change to freewheel stop mode, avoiding the unnecessary heating of the motor and the pump.

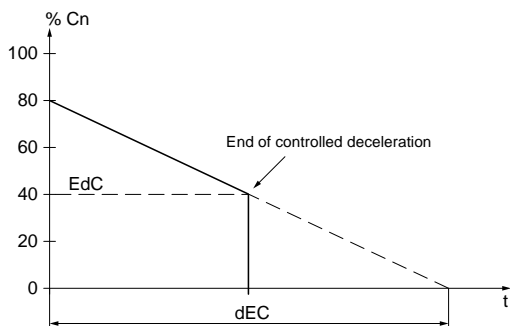

Decelerated stop by torque control during time dEC with threshold  $Edc$  for changing to freewheel stop mode  $Edc = 40\%$  of nominal motor torque

□ **Dynamic braking motor stop (application: stopping high inertia machines)**

This type of stop will decelerate the motor if there is considerable inertia.

The braking torque level (brc) can be adjusted. The dynamic braking time (T1) corresponds to the time taken to decelerate from 100% to 20% of the nominal motor speed. To improve braking at the end of deceleration, the starter injects a d.c. current for an adjustable period of time (T2).

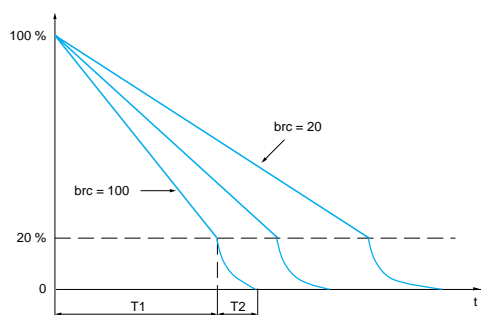

Dynamic braking stops for different braking torque levels brc

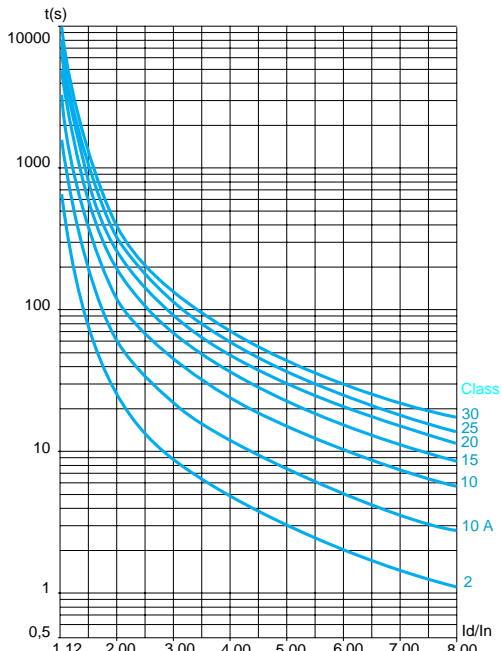

Motor thermal protection curves (cold)

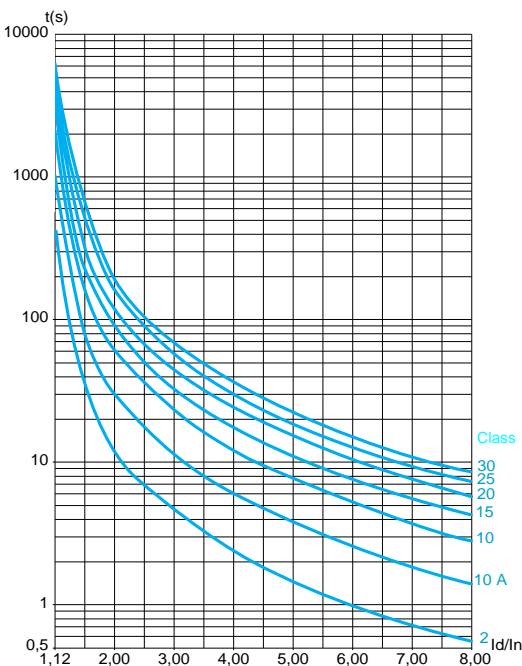

Motor thermal protection curves (warm)

### Protection functions

The Altistart 48 offers functions for protecting the motor and the machine.

#### Calculated motor thermal protection

The starter continuously calculates the temperature rise of the motor based on the nominal current which has been set and the actual current absorbed. In order to adapt the Altistart to individual motors and applications, several protection classes are offered in accordance with standard IEC 60947-4-2:

class 30, class 25, class 20 (severe application), class 15, class 10 (standard application), class 10 A, sub-class 2.

Different protection classes are defined for the starting capacities of the motor:

- cold start without thermal fault (corresponding to a stabilised motor thermal state, motor switched off)
- warm start without thermal fault (corresponding to a stabilised motor thermal state, at nominal power)

The motor thermal protection function can be disabled.

After the motor has stopped or the starter has been switched off, the thermal state is calculated even if the control circuit is not energised. The Altistart thermal control prevents the motor from restarting if the temperature rise is too high. If special motors are used which do not have thermal protection via curves, provide external thermal protection via probes or thermal overload relays.

The starter is factory-set to protection class 10.

The tripping curves are based on the relationship between the starting current  $I_s$  and the (adjustable) nominal motor current  $I_n$ .

#### Trip time (cold)

| Trip time for a standard application (class 10) |               |               | Trip time for a severe application (class 20) |               |               |
|---|---------------|---------------|---|---------------|---------------|
| $I_s = 3 I_n$                                   | $I_s = 4 I_n$ | $I_s = 5 I_n$ | $I_s = 3.5 I_n$                               | $I_s = 4 I_n$ | $I_s = 5 I_n$ |
| 46 s  | 23 s          | 15 s          | 63 s  | 48 s          | 29 s          |

#### Trip time (warm)

| Trip time for a standard application (class 10) |               |               | Trip time for a severe application (class 20) |               |               |
|---|---------------|---------------|---|---------------|---------------|
| $I_s = 3 I_n$                                   | $I_s = 4 I_n$ | $I_s = 5 I_n$ | $I_s = 3.5 I_n$                               | $I_s = 4 I_n$ | $I_s = 5 I_n$ |
| 23 s  | 12 s          | 7.5 s         | 32 s  | 25 s          | 15 s          |

#### Reset motor thermal state

Activating the function resets the motor thermal state calculated by the starter to zero.

#### Motor thermal protection with PTC probes

The starter integrates the processing of PTC probes, thus avoiding the use of an external device. The "PTC probe thermal overshoot" fault or alarm can be indicated using a configurable logic output or displayed via the serial link. The function can be disabled.

Note: The "PTC probe protection" and "calculated motor thermal protection" functions are independent and can be active simultaneously.

**Starter ventilation:** The cooling fan on the starter is switched on as soon as the heatsink temperature reaches 50°C. It is switched off when the temperature returns to 40°C.

#### Starter thermal protection

The starter is protected against thermal overloads by an analogue thermal probe.

# Soft starters

## Altistart 48 soft start - soft stop units

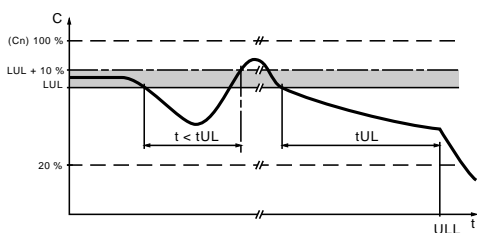

Motor underload detection (ULL)

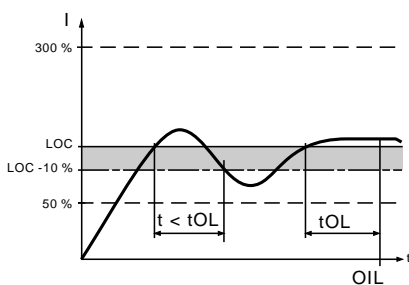

Motor overcurrent detection (OIL)

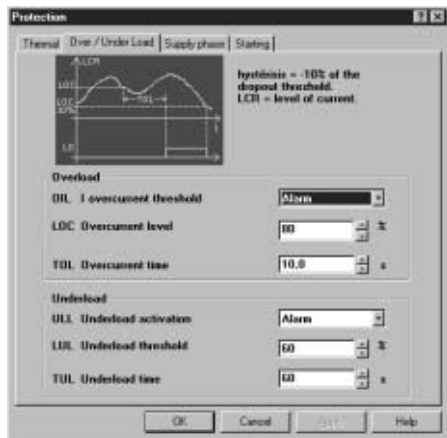

Configuring the starter overload and underload with PowerSuite on a PC

### Protection functions (continued)

#### ■ Motor underload protection

The starter detects a motor underload if the motor torque falls below a preset torque threshold (LUL) for a specific (adjustable) period of time (tUL). The motor underload threshold can be set between 20% and 100% of the nominal motor torque. The permissible underload duration can be set between 1 and 60 s. The detection function can trigger an alarm or a fault. The detection function can be disabled. The "motor underload detected" alarm can be indicated by a configurable logic output and/or displayed via the serial link in the state of the starter. The "motor underload detected" fault (ULF) locks the starter and can be displayed via the serial link.

#### ■ Excessive acceleration time protection

This protection function can be used to detect a start which takes place in adverse conditions. Examples of such conditions include a locked rotor or a motor unable to reach its nominal rotation speed. If the start duration is greater than the value set (between 10 and 999 s), the drive changes to fault mode. The function can be disabled.

#### ■ Current overload protection

The starter detects a current overload if the motor current exceeds a preset overcurrent threshold (LOC) for a specific (adjustable) period of time (tOL). The overcurrent threshold can be set between 50% and 300% of the nominal motor current. The permissible overcurrent duration can be set between 0.1 and 60 s. This function is only active in steady state. The detection function can trigger an alarm or a fault. It can also be disabled. The "current overload detected" alarm can be indicated by a configurable logic output and/or displayed via the serial link. The "current overload detected" fault (OLC) locks the starter and can be displayed via the serial link in the state of the starter.

#### ■ Protection against line phase inversion

This function can be used to detect the direction of rotation of the motor phases and, if it is enabled, to indicate a fault when the direction of rotation is reversed.

#### ■ Time before restarting

This function can be used to avoid several consecutive starts which may cause:

- the thermal overheating of the application, which is not permitted
- a thermal fault which will require maintenance work to be carried out
- overcurrents (if the direction of rotation is reversed) or repeats (run/stop commands)

Following a stop command, the motor can only restart once the preset time delay has elapsed. The motor is restarted once the time delay has elapsed if a run command is still valid or if a new run command is sent. Adjustment range: 0 to 999 s.

#### ■ Motor phase loss detection

The function is used to adjust the sensitivity of the protection function in order to detect a loss of current or a low current in one of the three motor phases for at least 0.5 s or in all three motor phases for at least 0.2 s. The value of the minimum current level can be set between 5% and 10% of the starter nominal current.

#### ■ Automatic restart

After locking on a fault, the function permits up to six restart attempts at intervals of 60 s if the fault has disappeared and the run commands are still present. After the sixth attempt, the starter will remain locked and the fault will have to be reset before a restart is permitted. If the function is active, the fault relay remains activated if line phase loss, motor phase loss or line frequency out of tolerance faults are detected. This function can only be used in 2-wire control.

### Advanced adjustment functions

#### ■ Torque limit

Designed primarily for high inertia and constant torque conveyor applications, the function restricts the torque ramp reference to the preset value.

For example, the function can be used to limit the torque to a constant value throughout the starting period.

Adjustment range: 10% to 200% of the nominal motor torque.

#### ■ Voltage boost level

The function can be used to avoid any "starting" torque (phenomenon caused by friction on stopping or by mechanical play). When a run command is sent, the starter applies a fixed voltage to the motor for a limited period of time before starting. The function can be disabled.

The voltage setting value varies between 50% and 100% of the nominal motor voltage.

#### ■ Connecting the starter to the motor delta terminal

ATS48...Q starters connected to motors with delta terminals can be wired in series in the motor windings. This type of connection reduces the current in the starter by a ratio of  $\sqrt{3}$ , which enables a lower rating starter to be used. The nominal current and limiting current settings as well as the current displayed during operation are on-line values and are indicated on the motor. For this application, the braking or decelerating stop functions are inactive. Only freewheel stopping is possible. The adjustment range of the nominal motor current and the limiting current are multiplied by  $\sqrt{3}$  if the function is selected.

This function is not compatible with the following functions: motor phase loss detection, motor preheating, cascade, decelerated stop and dynamic braking. Use the scheme recommended on page 60524/4 for this type of configuration.

#### ■ Test on low power motor

This function can be used to test a starter on a motor whose power is very much lower than that of the starter. It can be used for example to check the electrical wiring of a device.

The function is automatically cancelled when the starter is switched off.

The next time the starter is switched on, the starter returns to its initial configuration.

#### ■ Activation of the cascade function

This function can be used to start and decelerate several cascaded motors with a single starter.

In order to gain maximum benefit from torque control, it is advisable to use motors with powers between 0.5 and 1 times the power of the motor.

The wiring diagram for the cascaded motor function is shown on page 60524/6.

This function is not compatible with the following functions: motor preheating and connection to the motor delta terminal.

#### ■ Line frequency

The following frequencies can be selected for the function:

- 50 Hz. The frequency fault monitoring tolerance is  $\pm 20\%$ .

- 60 Hz. The frequency fault monitoring tolerance is  $\pm 20\%$ .

- Automatic detection of the line frequency by the starter. The frequency fault monitoring tolerance is  $\pm 6\%$ .

50 Hz and 60 Hz are recommended if the power supply is provided by a generating set, given their high tolerance.

#### ■ Reset kWh or the operating time

Sets the value of the power in kWh or the operating time value to 0. The calculation of the values is updated once the reset command has been sent.

#### ■ Return to factory settings

The function can be used to reset each setting to its initial value (starter factory setting, see page 60526/2).

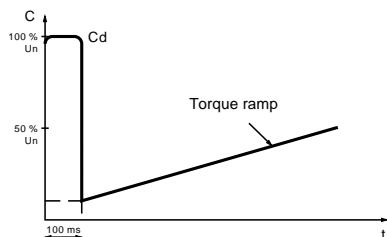

Application of a voltage boost equal to 100% of the nominal motor voltage

### 2<sup>nd</sup> motor adjustment functions

In order to access the 2nd motor adjustment functions, one logic input must be assigned to the second set of motor parameters function. The adjustment functions and ranges are identical for both sets of motor parameters.

The settings are as follows (see page 60526/3):

- Nominal motor current
- Limiting current
- Acceleration ramp time
- Initial starting torque
- Deceleration ramp time
- Threshold for changing to freewheel stop mode at the end of deceleration
- Maximum torque limit

### Communication functions

The Altistart 48 is supplied with an RS 485 multidrop serial link with Modbus protocol as standard. The serial link is configured in the Communication menu using:

- The address of the starter, which can be set between 0 and 31
- The communication speed, which can be set at: 4800, 9600 or 19200 bps
- The format of the communication data. The following formats can be selected:
  - 8 data bits, odd parity, 1 stop bit
  - 8 data bits, even parity, 1 stop bit
  - 8 data bits, no parity, 1 stop bit
  - 8 data bits, no parity, 2 stop bits
- The time-out, which can be set between 1 and 60 s

### PowerSuite advanced dialogue solutions

The PowerSuite advanced dialogue solutions (see pages 60200/2 and 60200/3) offer the following advantages:

- Connection to the Altistart 48 and access to the adjustment, monitoring and control functions
- Display of messages in plain text in 5 languages (English, French, German, Spanish and Italian)
- Preparation and saving of settings to hard disk
- Comparison and editing of settings using office automation tools
- Downloading of starter settings to the PC and uploading from the PC to the starter

### Application monitoring functions

The monitoring functions provide the following information:

- Cosine  $\phi$ , displayed between 0.00 and 1.00
- Motor thermal state: 100% corresponds to the thermal state of the motor consuming the permanently set nominal current
- Motor current: displayed in amperes between 0 and 999 A and in kilo amperes between 1000 and 9999 A
- The operating time corresponding to the total number of starter operating hours during heating, acceleration, steady state, deceleration, braking and continuous bypass operation. It is displayed in hours between 0 and 999 hours and in kilo hours between 1000 and 65536 hours.
- The active power is displayed between 0 and 255%, where 100% corresponds to the power at the set nominal current and at full voltage.
- The motor torque is displayed between 0 and 255%, where 100% corresponds to the nominal torque.
- The active power consumed is displayed in kW. The line voltage value must be configured. The accuracy of this setting will depend on the error between the voltage configured and the actual voltage.
- Power in kW/h displayed with PowerSuite
- The following starter states are shown in the display of the current state:
  - Starter without run command and power not supplied
  - Starter without run command and power supplied
  - Acceleration/deceleration in progress
  - Steady state operation
  - Braking in progress
  - Starter in current limiting mode
  - Starting time delay not elapsed
  - Last fault. Displays the last fault which occurred.
  - Phase rotation direction. Displays the direction of rotation (direct or indirect).
  - **Terminal locking code**
  - An access code can be used to protect access to the adjustment and configuration parameters of the starter. Only the monitoring parameters will then be visible.



Displaying the commands and settings with PowerSuite on PC

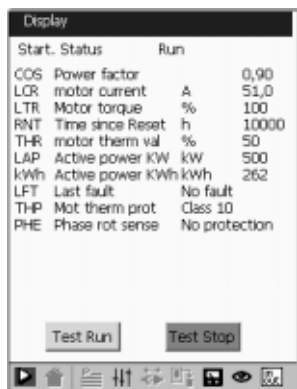

Monitoring the parameters with PowerSuite on PPC

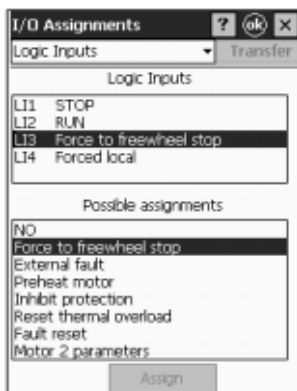

Assigning the logic inputs with PowerSuite on PPC

### Logic input application functions

The starter has 4 logic inputs:

- **2 logic inputs (RUN and STOP) are reserved for run/stop commands** which can be sent in the form of stay-put contacts or as pulsed contacts.
  - **2-wire control:** Starting and stopping are controlled by a single logic input. State 1 of the logic input controls starting and state 0 controls stopping.
  - **3-wire control:** Starting and stopping are controlled by 2 separate logic inputs. A stop is obtained on opening (state 0) the STOP input. The pulse on the RUN input is stored until the stop input opens.

- **2 logic inputs (LI3 and LI4) can be configured with the following functions:**

- **Freewheel stop:** When combined with a braked stop or decelerated stop command, activating the logic input will stop the motor in freewheel mode.
- **External fault:** Enables the starter to detect an external user fault (level, pressure, etc.). When the contact is open, the starter changes to fault mode.
- **Motor preheating:** Used to prevent the motor from freezing or to prevent temperature variations which may cause condensation. When the logic input is activated, an adjustable current flows through the motor after a time delay which can be set between 0 and 999 s. This current heats the motor without causing it to rotate. This function is not compatible with the following functions: connection to the motor delta terminal and cascading.
- **Force to local control mode:** If a serial link is used, this function can be used to change from line mode (control via serial link) to local mode (control via the terminal).
- **Inhibit all protection:** Enables the forced operation of the starter in an emergency by overriding the main faults (smoke extraction system for example).  
Warning: This type of use invalidates the starter warranty.
- **Reset motor thermal fault:** Enables the fault to be reset remotely.
- **Activation of the cascade function:** In this case, the motor thermal protection is disabled and relay R1 is configured as the fault isolation relay. Can be used to start and decelerate several motors one after the other with a single starter (see application diagram on pages 60524/6 and 60524/7).
- **Reset all faults:** Enables all faults to be reset remotely.
- **Second set of motor parameters:** Enables a second set of parameters to be selected to start and decelerate two different motors with a single starter.

### Logic output application functions

The starter has 2 logic outputs (LO1 and LO2) which, depending on their configuration, can be used for remote indication of the following states or events:

- Motor thermal alarm: Indicates that the motor thermal state has exceeded the alarm threshold and can be used for example to avoid starting a motor if the thermal reserve is insufficient.
- Motor powered: Indicates that there may be current in the motor.
- Motor overcurrent alarm: The motor current is higher than the threshold set.
- Motor underload alarm: The motor torque is lower than the threshold set.
- Motor PTC probe alarm: Indicates that the thermal state monitored by the PTC motor probe has been exceeded.
- Second set of motor parameters activated

### Relay and analogue output application functions

The starter has 3 relays, 2 of which are configurable.

- **End of starting relay R2:** Cannot be configured. The end of starting relay controls the bypass contactor on the starter. It is activated when the motor has completed the starting phase. It is deactivated when a stop command is sent and in the event of a fault. The starter regains control when a braking or deceleration command is sent.

#### ■ Relay R1 application functions

Relay R1 can be configured as follows:

- Fault relay: Relay R1 is activated when the starter is powered and there are no faults. It is deactivated when a fault occurs and the motor switches to freewheel mode.
- Isolating relay: The contact of relay R1 closes when a run command is sent and re-opens when a stop command is sent, at the end of deceleration on a decelerated stop or in the event of a fault. The line contactor is deactivated and the motor is isolated from the line supply (see application diagram page 60524/3).

#### ■ Relay R3 application functions

Relay R3 is configured to indicate the same states or events as logic outputs LO1 or LO2 (see above).

#### ■ Analogue current output AO application functions

- The analogue output AO provides an image of the following values: motor current, motor torque, motor thermal state, cosine  $\phi$ , active power.
- The following settings are associated with the analogue output:
  - the type of signal supplied: 0-20 mA or 4-20 mA
  - the scale setting of the signal. The function associates the maximum amplitude of the analogue output (20 mA) with a percentage of the nominal value of the parameter, which can be set between 50% and 500%.



Assigning the analogue output with PowerSuite on PC

### Function compatibility table

| Functions                              | Decelerating stop | Dynamic braking stop | Forced freewheel stop | Thermal protection | Motor phase loss detection | Connection to the motor delta terminal | Tests on low power motor | Cascaded motors | Motor preheating |
|--|-------------------|----------------------|-----------------------|--------------------|----------------------------|--|--------------------------|-----------------|------------------|
| Decelerating stop                      |                   |                      |                       |                    |                            |  |                          |                 |                  |
| Dynamic braking stop                   |                   |                      |                       |                    |                            |  |                          |                 |                  |
| Forced freewheel stop                  |                   |                      |                       |                    |                            |  |                          |                 |                  |
| Thermal protection                     |                   |                      |                       |                    |                            |  |                          |                 | (1)              |
| Motor phase loss detection             |                   |                      |                       |                    |                            | (1)                                    |                          |                 | (1)              |
| Connection to the motor delta terminal |                   |                      |                       |                    | (1)                        |  |                          |                 |                  |
| Tests on low power motor               |                   |                      |                       |                    |                            |  |                          |                 |                  |
| Cascaded motors                        |                   |                      |                       |                    |                            |  |                          |                 |                  |
| Motor preheating                       |                   |                      |                       | (2)                | (1)                        |  |                          |                 |                  |

- Compatible functions
- Incompatible functions
- Not applicable

(1) Motor phase loss not detected.

(2) Thermal protection is not provided during motor preheating.

# Soft starters

## Conventional starting of three-phase asynchronous motors

### Direct starting

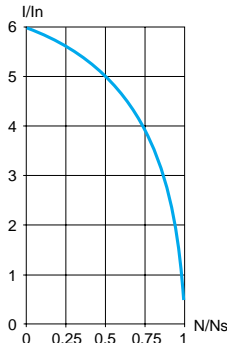

Starting current

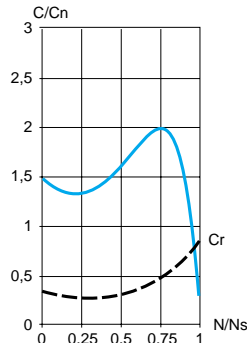

Starting torque

- Starting current: 4 to 8 times the nominal current
- Starting torque: 0.5 to 1.5 times the nominal torque
- Characteristics:
  - Motor with 3 terminals, low and medium power
  - On-load starting
  - High current peak and voltage drop
  - Simple device
  - Sudden starting for the mechanism
- No parameter adjustment

### "Star-delta" starting

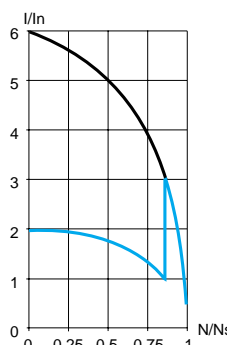

Starting current

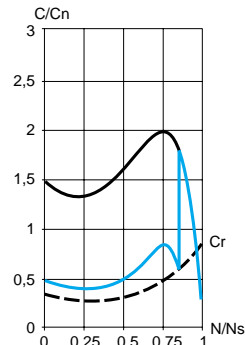

Starting torque

- Starting current: 1.8 to 2.6 times the nominal current
- Starting torque: 0.5 times the nominal torque
- Characteristics:
  - Motor with 6 terminals
  - No-load or low resistive torque starting
  - High current peaks and torque when changing to "star-delta" mode
  - A device requiring maintenance
  - Subject to mechanical stress when starting
- No parameter adjustment

### Rheostatic stator starting

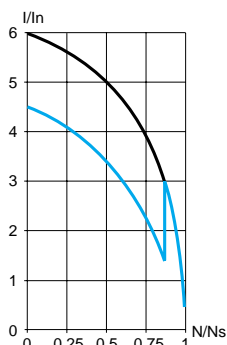

Starting current

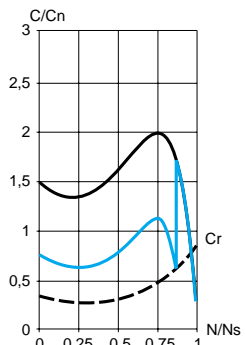

Starting torque

- Starting current: 4.5 times the nominal current
- Starting torque: 0.5 to 0.75 times the nominal torque
- Characteristics:
  - Motor with 3 terminals, high power
  - Starting with increasing resistive torque
  - High current peak
  - A large, bulky device requiring maintenance
  - Subject to mechanical stress when starting
- No parameter adjustment

### Auto transformer starting

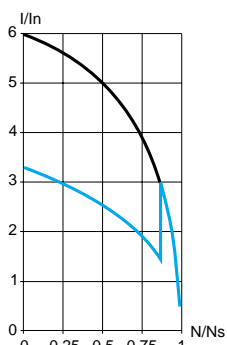

Starting current

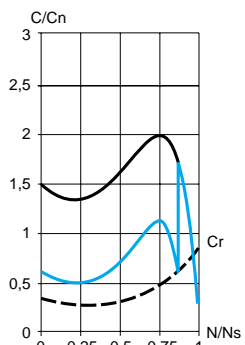

Starting torque

- Starting current: 1.7 to 4 times the nominal current
- Starting torque: 0.4 to 0.85 times the nominal torque
- Characteristics:
  - Motor with 3 terminals, high power
  - Large voltage drop and current peak when connected at full voltage
  - A complex, bulky device requiring maintenance
  - Subject to mechanical stress when starting
- No parameter adjustment

# Soft starters

## Progressive starting of three-phase asynchronous motors

### Conventional electronic starting with variable voltage and current limiting

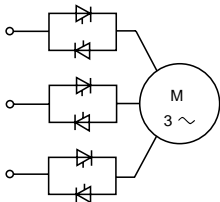

Schematic diagram

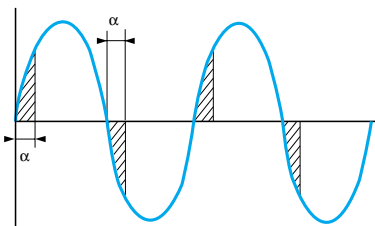

Firing angle

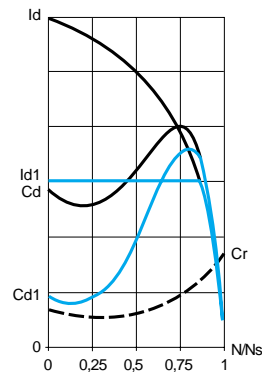

Figure 1

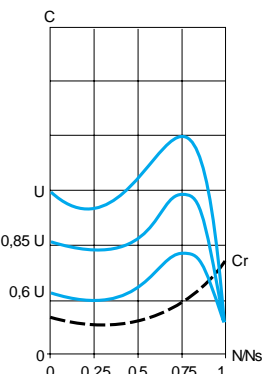

Figure 2

- A controller with 6 thyristors connected head to tail in each line phase is used to power the three-phase asynchronous motor by gradually increasing the voltage on start-up.
- Depending on the firing time and angle of the thyristors, it can be used to supply a voltage which will gradually increase at a fixed frequency.
- The gradual increase in the output voltage can either be controlled by the acceleration ramp, or by the value of the limiting current, or linked to both parameters.

- Figure 1 shows the behaviour of the torque in relation to the starting current. Limiting the starting current  $I_s$  to a preset value  $I_{s1}$  will reduce the starting torque  $T_{s1}$  to a value which is almost equal to the ratio of the square of currents  $I_s$  and  $I_{s1}$ .

**Example**

On a motor with the following characteristics:  $T_s = 2 T_n$  for  $I_s = 6 I_n$ , current limiting at  $I_{s1} = 3 I_n$  or  $0.5 I_s$  results in a starting torque:  $T_{s1} = T_s \times (0.5)^2 = 2 T_n \times 0.25 = 0.5 T_n$ .

- Figure 2 shows the torque/speed characteristic of a squirrel cage motor in relation to the supply voltage. The torque varies like the square of the voltage at a fixed frequency. The gradual increase in the voltage prevents the instantaneous current peak on power-up.

### Advantages of starting with the Altistart 48

- Conventional electronic starting  
To rectify problems caused by:
  - mechanical stress when starting
  - hydraulic transients during acceleration and deceleration in pump applications
 Conventional electronic starting requires the use of several current limits or the switching of several voltage ramps.  
The settings become complicated and must be modified every time the load changes.
- Starting with the Altistart 48  
The Altistart 48 torque control enables starting without mechanical stress and the smooth control of hydraulic transients with a single acceleration ramp.  
The settings are simple and effective, whatever the load.