

# Rotary encoders **Osicoder<sup>®</sup>**

Catalogue  
January

# 06





# Rotary encoders Osicoder®

---

■ General .....	page 2
Selection guide .....	page 8

## Incremental encoders

### ■ Ø 40 mm incremental encoders

□ Characteristics, schemes .....	page 10
□ References .....	page 11
□ Dimensions, connections .....	pages 18 and 19

### ■ Ø 58 mm incremental encoders and parameterable versions

□ Characteristics, schemes .....	page 12
□ References .....	pages 13 to 15
□ Dimensions, connections .....	pages 18 and 19

### ■ Ø 90 mm incremental encoders

□ Characteristics, schemes .....	page 16
□ References .....	page 17
□ Dimensions, connections .....	pages 18 and 19

## Single turn absolute encoders

### ■ Ø 58 mm single turn absolute encoders

□ Characteristics, schemes .....	page 20
□ References .....	page 21
□ Dimensions, connections .....	pages 24 and 25

### ■ Ø 90 mm single turn absolute encoders

□ Characteristics, schemes .....	page 22
□ References .....	page 23
□ Dimensions, connections .....	pages 24 and 25

## Multiturn absolute encoders

### ■ Ø 58 mm multiturn absolute encoders

□ Characteristics, schemes .....	page 26
□ References .....	page 27
□ Dimensions, connections .....	pages 30 to 33

### ■ Ø 90 mm multiturn absolute encoders

□ Characteristics, schemes .....	page 28
□ References .....	page 29
□ Dimensions, connections .....	pages 30 to 33

## Accessories

### ■ for incremental, single turn and multiturn encoders

□ Characteristics .....	page 34
□ References .....	pages 35 to 37
□ Dimensions .....	pages 38 to 41

## Multiturn absolute encoders on bus

■ CANopen Ø 58mm encoders .....	pages 42 to 45
■ PROFIBUS-DP Ø 58mm encoders .....	pages 46 to 49
■ Accessories for CANopen and PROFIBUS-DP encoders .....	pages 50 and 51

### Applications

The increase in the power of processing systems, coupled with the requirements for high productivity, has created the need for continuous information in all areas of production regarding:

- counting, positioning by counting,
- absolute positioning,
- speed control.

### Example

The positioning of a moving part is fully controlled by the processing system via the encoder.

- Processing units  
please refer to our "Premium automation platform" catalogue.

- Variable speed drives  
please refer to our "Variable speed drives and starters" catalogue.

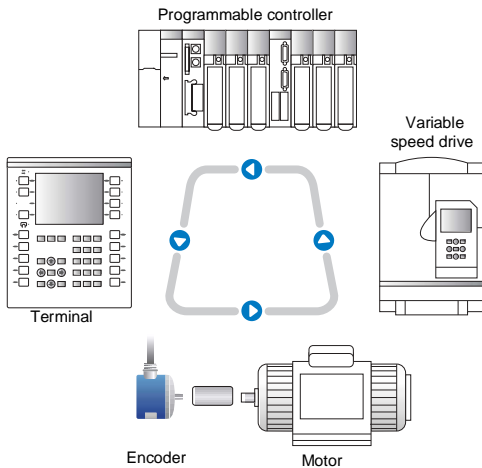

### Principle of the opto-electronic rotary encoder

The opto-electronic rotary encoder is an angular position sensor.

Mechanically coupled to a driving spindle of a machine, the shaft of the encoder rotates a disc that comprises a succession of opaque and transparent sectors.

Light from light emitting diodes (LEDs) passes through the transparent sectors of the disc as they appear and is detected by photosensitive diodes.

The photosensitive diodes, in turn, generate an electrical signal which is amplified and converted into a digital signal before being transmitted to a processing system or an electronic variable speed drive.

The electrical output of the encoder therefore represents, in digital form, the angular position of the input shaft.

### Types of opto-electronic rotary encoder

- Incremental encoders:  
Counting, positioning by counting, speed.
- Parameterable incremental encoders:  
Multiplication of the basic resolution of the disc using dip switches (the factory setting being that of the lowest value).
- Single turn and multiturn absolute encoders:  
Absolute positioning.
- Fieldbus multiturn absolute encoders:  
CANopen and PROFIBUS-DP.

### Incremental encoder

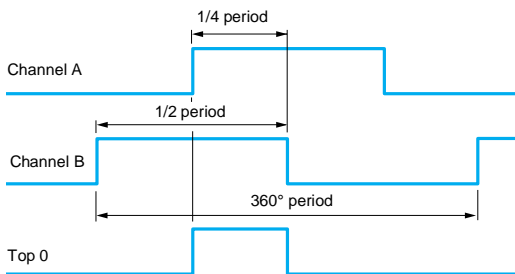
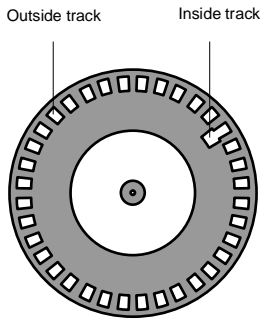

### Principle

The disc of an incremental encoder comprises 2 types of track:

- one or several outside tracks (channels A and B), comprising “n” equal angular steps that are alternately opaque and transparent, with “n” being the resolution or number of periods of the encoder,
- an inside track comprising a single window, which serves as the reference point and enables reinitialisation at each revolution (top 0).

### Schemes and settings

The operation of the photosensitive elements (LEDs + photosensitive diodes) is based on the real-time differential optical reading principle:

- the photosensitive elements of tracks A and B are offset so that each will simultaneously read only its respective slot (channels A and B are 90° electrically offset),
- the electronics operate following the principle of real-time differential measurement.

Channel B (rising edge) arriving before A in the clockwise direction viewed from base side.

Period: 360° electrical.

Cyclic ratio: 180° electrical ± 10%.

Phase displacement: 90° electrical ± 25%.

### Advantages of real-time differential optical reading

#### Reading by offset photosensitive elements

- Radial play of encoder shaft greater than 30%, which is higher than traditional optical reading encoders.
- Maintains a phase displacement of channels A and B within the tolerance limits of the unit.

#### Triple light source emission

- Maintains cyclic ratio, even in the event of:
  - failure of one of the 3 light sources,
  - diminishing efficiency of the light sources (up to 30%),
  - fine dust deposit on the optical components, reducing signal strength of the photosensitive elements (up to 30%).

These advantages are the reliability factors of the XCC encoders.

### Absolute encoder

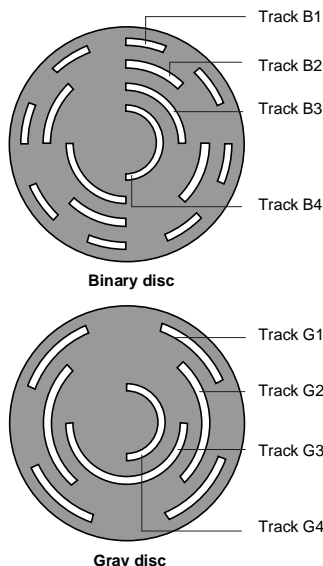

### Principle

The disc of an absolute encoder comprises “n” concentric tracks, equally divided into alternate opaque and transparent segments, and each track has its own transmitter and receiver.

The inside track is half opaque and half transparent. Reading of this MSB (Most Significant Bit) track determines in which half-turn the encoder is situated.

The next track is divided into 4 quarters, alternately opaque and transparent. The reading of this track, in conjunction with the previous track, determines in which quarter-turn the encoder is situated.

The following tracks enable successive determination of which eighth-turn, sixteenth-turn, etc. the encoder is situated.

The outside track corresponds to the LSB (Least Significant Bit) and provides the final accuracy. It has 2 to the power “n” points corresponding to the resolution of the encoder. Therefore, for each angular position of the shaft, the disc provides a code. This code can either be binary or Gray.

Following one complete revolution of the encoder, the same coded values are repeated.

The multiturn absolute encoder, in addition to providing the digital position within the revolution, also provides the total number of revolutions.

**Absolute encoder (continued)**

**Binary coding**

The binary code is directly usable by processing systems (programmable controllers for example) in order to execute calculations or comparisons, but has the disadvantage of having several bits which change state between 2 positions.

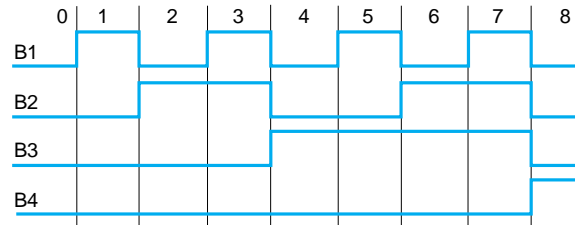

**Gray coding**

The Gray code offers the advantage of only changing one bit between 2 consecutive numbers.

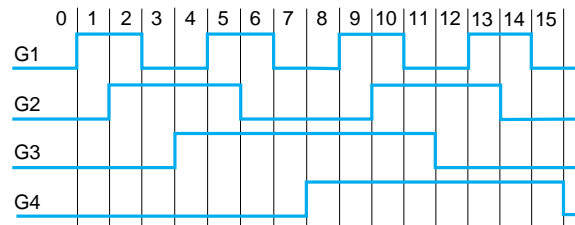

**Example of Gray code disc**

	0	1	2	3	4	5	6	7	8	9	10	11	12	13	14	15	16	17	18	19	20	21	22	23	24
2 <sup>0</sup>	0	1	1	0	0	1	1	0	0	1	1	0	0	1	1	0	0	1	1	0	0	1	1	0	0
2 <sup>2</sup>	0	0	1	1	1	1	0	0	0	0	1	1	1	1	0	0	0	0	1	1	1	1	0	0	0
2 <sup>4</sup>	0	0	0	0	1	1	1	1	1	1	1	0	0	0	0	0	0	0	1	1	1	1	1	1	1
2 <sup>8</sup>	0	0	0	0	0	0	0	0	1	1	1	1	1	1	1	1	1	1	1	1	1	1	1	1	0
2 <sup>16</sup>	0	0	0	0	0	0	0	0	0	0	0	0	0	0	0	0	1	1	1	1	1	1	1	1	

Representation of the first 24 decimal values corresponding to the reading of the first 5 tracks.

**Advantages of position detection by an absolute encoder**

An absolute encoder continuously provides a code that is an image of the actual position of the moving object being monitored.

On power-up, or restart following a supply failure, the encoder provides data that is directly exploitable by the processing system.

### 7 characteristics to be established

#### 1 Function

- Incremental encoder  
Provides counting indication.
- Single turn absolute encoder  
Provides absolute position within each revolution.
- Multiturn absolute encoder  
Provides absolute position within each revolution and indicates total number of revolutions.

#### 2 Diameter of housing

- Incremental encoders  
Ø 40, 58 and 90
- Single turn and multiturn absolute encoders  
Ø 58 and 90

#### 3 Diameter of shaft

- Ø 6 mm to 30 mm, depending on model.
- Reduction collars  
For Ø 58 and 90 mm encoders, with Ø 14, 15 and 30 mm through shaft, reduction collars are available to reduce the diameters:
  - from 14 to 6, 8, 10 and 12
  - from 15 to 6, 8, 10, 12 and 14
  - from 30 to 12, 16, 20 and 25.

#### 4 Type of shaft

- Solid shaft  
The shaft of the encoder is mechanically linked to a drive shaft using a flexible coupling, which eliminates alignment inaccuracies.
- Through shaft/Hollow shaft  
The encoder is mounted directly on the drive shaft. A flexible mounting kit prevents encoder rotation and compensates for alignment inaccuracies.

#### 5 Connection method

- Pre-cabled with 2 m long shielded cable or M23/M12 connector.
- Radial type connection.

#### 6 Resolution

- Number of points per revolution.
- Number of revolutions (for multiturn absolute encoders).
- On Ø 58 parameterable incremental encoders, this resolution can be adjusted using dip switches (multiplication factor up to 16 times on 9 basic resolutions).

#### 7 Type of output

- Incremental encoders  
5 V output driver, RS 422, 4.75...30 V.  
Push-pull output driver, 5...30 V, 11...30 V.
- Single turn absolute encoders (depending on model)  
Push-pull output driver, 11...30 V, binary code or Gray code.  
SSI output without parity, 13-bit clock, 11...30 V, binary code or Gray code.
- Multiturn absolute encoders (depending on model)  
SSI output without parity, 25-bit clock, 11...30 V, binary code or Gray code.
- Parallel outputs available using converter connecting cables  
The SSI versions can be converted to a parallel version by using the deserialisation connecting cable (see pages 33 and 36).
- Multiturn absolute encoders, communicating version, fieldbus:
  - CANopen: 11...30 V (see page 42).
  - PROFIBUS-DP: 11...30 V (see page 46).

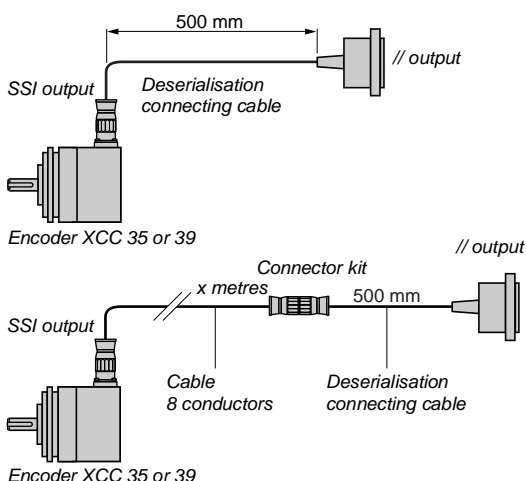

### Installation precautions

#### Type of cables

In an environment subject to considerable electrical interference, it is recommended that cables with several twisted pairs, reinforced by general shielding, be used.

For the signals, it is recommended that standard 0.14 mm<sup>2</sup>/0.22 mm<sup>2</sup> conductors be used.

For 5 V supply encoders.

Due to line voltage drops, it is recommended that the 0 V and + V cables have the following minimum cross-sectional areas:

- 0.14 mm<sup>2</sup> if the encoder-supply distance is less than 30 m,
- 0.22 mm<sup>2</sup> if the encoder-supply distance is greater than 30 m.

#### Cabling

Separate, by as much as possible, the connecting cables to encoders and power cables. Also, avoid parallel cable runs. Maintain a distance of at least 20 cm and, in the event of cables crossing, ensure that the crossovers are at right-angles.

When using cables with twisted pairs (shielded or non shielded) group signal cables in common pairs.

In environments subject to electrical interference, it is recommended to earth the encoder base using one of the fixing screws.

Connect the control inputs to a potential (absolute encoder).

Connect all 0 V connections back to a star point, i.e. only one and same referential. Earth the shielding throughout 360° using tap-off braids. This is to be done at both ends of each cable. To earth the shielding use at least 4 mm<sup>2</sup> cable.

As much as possible, earth the 0 V of the supply to the encoders on the supply side. Maximum frequency of signals for SSI depending on distance:

Indicative values that can vary depending on the cable characteristics

Distance (m)	Frequency (kHz)
50	400
100	300
200	200
400	100

#### Supply

It is imperative that regulated and smoothed power supplies, with a ripple factor on 24 V of 500 mV and on 5 V of 200 mV, are used that are specifically for the encoder. Telemecanique ABL7 range power supplies are available. Please refer to our "Power supplies, splitter boxes and interfaces" catalogue.

For 5...30 V encoders, the supply via a transformer with a 24 V rms rectified and smoothed secondary is prohibited, since the d.c. voltage obtained is higher than the supply voltage limits of the encoder.

Prior to powering-up for the first time, ensure that the rated supply voltage of the encoder is suitable for the supply.

## Connection and powering-up precautions

### Connection

The plugging-in or unplugging of a connector version encoder must only be done whilst the supply is disconnected.

Encoder supplied by central unit:

- disconnect supply to central unit,
- proceed with connection or disconnection,
- re-establish supply to central unit.

Encoder supplied by source external to central unit:

- disconnect supply to central unit, then disconnect supply to encoder,
- proceed with connection or disconnection,
- re-establish supply to encoder, then re-establish supply to central unit.

### Powering-up

For synchronisation reasons, the powering-up or switching-off of the encoder must coincide with that of its associated electronics.

Encoder type			Incremental encoders			
Applications			Counting indication			
Diameter of housing			Ø 40 mm	Ø 58 mm	Ø 58 mm parameterable (multi-resolution) (1)	Ø 90 mm
Shaft	Solid		Ø 6 mm	Ø 6 mm and Ø 10 mm	Ø 10 mm	Ø 12 mm
	Through		Ø 6 mm	Ø 14 mm Ø 6, 8, 10 and 12 mm (with reduction collar)	Ø 14 mm Ø 6, 8, 10 and 12 mm (with reduction collar)	Ø 30 mm Ø 12, 20 and 25 mm (with reduction collar)
Resolution	Incremental encoders	100 points	100 points	100 points	–	100 points
		256 points	–	–	256 to 4096 points	–
		360 points	360 points	360 points	360 to 5760 points	360 points
		500 points	500 points	500 points	500 to 8000 points	500 points
		1000 points	1000 points	1000 points	–	1000 points
		1024 points	1024 points	1024 points	1024 to 16 384 points	1024 points
		2500 points	–	2500 points	–	2500 points
		3600 points	–	–	–	3600 points
		4096 points	–	–	–	–
		5000 points	–	5000 points	5000 to 80 000 points	5000 points
	10 000 points	–	–	–	10000 points	
	Absolute encoders	4096 points/8192 turns (12-bit/13-bit)	–	–	–	–
		8192 points	–	–	–	–
		8192 points/4096 turns (13-bit/12-bit)	–	–	–	–
–		–	–	–	–	
Output stage/ supply (2)	Incremental encoders	Type R (N)	5 V, RS 422, 4.5...5.5 V	–	–	5 V, RS 422, 4.5...5.5 V
		Type K (N)	Push-pull, 11...30 V	–	–	Push-pull, 11...30 V
		Type X	–	5 V, RS 422, 4.75...30 V	5 V, RS 422, 4.75...30 V	–
		Type Y	–	Push-pull, 5...30 V	Push-pull, 5...30 V	–
		Type Z	–	–	–	–
	Absolute encoders	Type KB (N) or KG (N)	–	–	–	–
		Type SB (N) or SG (N)	–	–	–	–
		Type C	–	–	–	–
		Type F	–	–	–	–
		–	–	–	–	–
Connection	Pre-cabled, radial		●	–	–	–
	Connector, radial, M23		–	●	●	●
	Terminal block, radial		–	–	–	–
Type reference			XCC 14●●●●●	XCC 15●●●●●	XCC 15●●●●M●●●	XCC 19●●●●●
Page(s)			11	13 to 15		17

(1) Parameterable version: multiplication of the basic resolution of the disc using dip switches, the factory setting being that of the lowest value.

Single turn absolute encoders		Multiturn absolute encoders			Accessories for encoders
Absolute position indication within a revolution		Absolute position indication within a revolution and indication of the number of revolutions		Fieldbus: PROFIBUS-DP, CANopen	
					 <ul style="list-style-type: none"> <li>- Shaft couplings with spring,</li> <li>- anti-rotation devices,</li> <li>- reduction collars,</li> <li>- pre-wired connectors,</li> <li>- etc.</li> </ul>
Ø 58 mm	Ø 90 mm	Ø 58 mm	Ø 90 mm	Ø 58 mm	
Ø 6 mm and Ø 10 mm Ø 14 mm Ø 6, 8, 10 and 12 mm (with reduction collar)	Ø 12 mm Ø 30 mm Ø 12, 20 and 25 mm (with reduction collar)	Ø 6 mm and Ø 10 mm Ø 14 mm Ø 6, 8, 10 and 12 mm (with reduction collar)	Ø 12 mm Ø 30 mm Ø 16, 20 and 25 mm (with reduction collar)	Ø 10 mm Ø 15 mm (hollow shaft) Ø 6, 8, 10, 12 and 14 mm (with reduction collar)	
-	-	-	-	-	
-	-	-	-	-	
-	-	-	-	-	
-	-	-	-	-	
-	-	-	-	-	
-	-	-	-	-	
-	-	-	-	-	
-	-	-	-	-	
-	-	-	-	-	
-	-	-	-	-	
-	-	-	-	-	
-	-	4096 points/8192 turns	-	-	
8192 points	8192 points	-	-	-	
-	-	8192 points/4096 turns	8192 points/4096 turns	8192 points/4096 turns	
-	-	-	-	-	
-	-	-	-	-	
-	-	-	-	-	
-	-	-	-	-	
Push-pull, 11...30 V, binary or Gray	Push-pull, 11...30 V, binary or Gray	-	-	-	
SSI, 11...30 V, binary or Gray	SSI, 11...30 V, binary or Gray	SSI, 25-bit, 11...30 V, binary or Gray	SSI, 25-bit, 11...30 V, binary or Gray	-	
-	-	-	-	11...30 V, CANopen	
-	-	-	-	11...30 V, PROFIBUS-DP	
-	-	-	-	-	
●	●	●	●	●	
-	-	-	-	●	
XCC 25●●●●●	XCC 29●●●●●	XCC 35●●●●●	XCC 39●●●●●	XCC 35●●●●●FB XCC 35●●●●●CB	XCC R, XCC P, XZC
21	23	27	29	44 and 48	35 and 50

(2) Characteristics of the output stage/supply types:

- type R (N): 5 V output driver, RS 422, 4.5...5.5 V.
- type K (N): push-pull output driver, 11...30 V.
- type X: 5 V output driver, RS 422, 4.75...30 V.
- type Y: push-pull output driver, 5...30 V.
- KB (N) or KG (N) output: push-pull output driver, 11...30 V, binary code KB (N) or Gray code KG (N).
- type SB (N) or SG (N): SSI output without parity, 13 or 25-bit clock, 11...30 V, binary code SB (N) or Gray code SG (N).
- type KB (N) or KG (N): push-pull output driver, 11...30 V, binary code KB (N) or Gray code KG (N) with multiturn connecting cable.
- type C: Binary CANopen serial link.
- type F: Binary PROFIBUS serial link, RS 485.

## Environment

Encoder type		XCC 1406P●●●●	XCC 1406T●●●●
Conformity		CE	
Temperature	Operation (housing)	°C	- 20...+ 80
	Storage	°C	- 30...+ 85
Degree of protection	Conforming to IEC 60529	IP 54	IP 52
Vibration resistance	Conforming to IEC 60068-2-6	10 gn (f = 10...500 Hz)	
Shock resistance	Conforming to IEC 60068-2-27	30 gn, duration 11 ms	
Resistance to electromagnetic interference	Electrostatic discharges	Conforming to IEC 61000-4-2: level 3, 8 kV air; 4 kV contact	
	Radiated electromagnetic fields (electromagnetic waves)	Conforming to IEC 61000-4-3: level 3, 10 V/m	
	Fast transients (Start/Stop interference)	Conforming to IEC 61000-4-4: level 3, 2 kV (1 kV for inputs/outputs)	
	Surge withstand	Conforming to IEC 61000-4-5: level 2, 1 kV	
Materials	Base	Aluminium or Zamak	
	Housing	Aluminium or Zamak	
	Shaft	Stainless steel or Aluminium	
	Ball bearings	688AZZ1	

## Mechanical characteristics

Shaft type	mm	Ø 6, solid shaft (g7)	Ø 6, through shaft (H7)
Maximum rotational speed	Continuous	9000 rpm	
Shaft moment of inertia	g.cm <sup>2</sup>	10	5
Torque	N.cm	0.2	0.25
Maximum load	Radial	daN	2
	Axial	daN	1

## Electrical characteristics

Connection		Radial: pre-cabled, 8 x 0.14 mm <sup>2</sup> shielded, Ø ext = 6 mm, length = 2 m Crimped metal cable entry	pre-cabled, 8 x 0.14 mm <sup>2</sup> shielded, Ø ext = 6 mm, length = 2 m Crimped metal cable entry
Frequency	kHz	100	
Number of channels		3 channels: A, B, top 0 and complements A, B, 0	
<b>Encoders with type R output stage: 5 V output driver, RS 422, 4.5...5.5 V supply</b>			
Supply voltage		= 5 V ± 10% Max. ripple: 200 mV	
Current consumption, no-load	mA	100 max.	
Output current	mA	40 max.	
Output levels	Low level	(I <sub>s</sub> = 20 mA) 0.5 V max.	
	High level	(I <sub>s</sub> = 20 mA) 2.5 V min.	
<b>Encoders with type K output stage: push-pull output driver, 11...30 V supply</b>			
Supply voltage		= 11 V...30 V Max. ripple: 500 mV	
Current consumption, no-load	mA	75 max.	
Protection		Against short-circuits and reverse polarity	
Output current	mA	40 max.	
Output levels	Low level	(I <sub>s</sub> = 20 mA) 1.5 V max.	
	High level	(I <sub>s</sub> = 20 mA) V supply - 3 V min.	

## Schemes

### Type R output stage

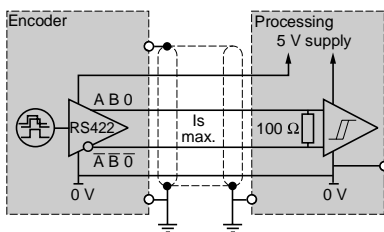

### Type K output stage

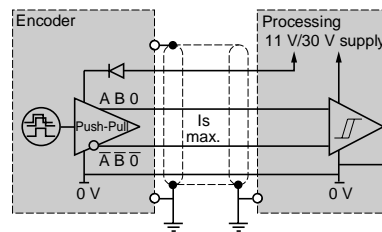

1 055 60



XCC 1406PR●●●

## Solid shaft, Ø 6 mm

Resolution	Connection method	Output stage type (1)	Supply voltage	Reference	Weight kg
100 points	Pre-cabled radial L = 2 m	5 V, RS 422	4.5...5.5 V	XCC 1406PR01R	0.355
		Push-pull	11...30 V	XCC 1406PR01K	0.355
360 points	Pre-cabled radial L = 2 m	5 V, RS 422	4.5...5.5 V	XCC 1406PR03R	0.355
		Push-pull	11...30 V	XCC 1406PR03K	0.355
500 points	Pre-cabled radial L = 2 m	5 V, RS 422	4.5...5.5 V	XCC 1406PR05R	0.355
		Push-pull	11...30 V	XCC 1406PR05K	0.355
1000 points	Pre-cabled radial L = 2 m	5 V, RS 422	4.5...5.5 V	XCC 1406PR10R	0.355
		Push-pull	11...30 V	XCC 1406PR10K	0.355
1024 points	Pre-cabled radial L = 2 m	5 V, RS 422	4.5...5.5 V	XCC 1406PR11R	0.355
		Push-pull	11...30 V	XCC 1406PR11K	0.355

1 055 61



XCC 1406TR●●●

## Through shaft, Ø 6 mm (2)

Resolution	Connection method	Output stage type (1)	Supply voltage	Reference	Weight kg
100 points	Pre-cabled radial L = 2 m	5 V, RS 422	4.5...5.5 V	XCC 1406TR01R	0.405
		Push-pull	11...30 V	XCC 1406TR01K	0.405
360 points	Pre-cabled radial L = 2 m	5 V, RS 422	4.5...5.5 V	XCC 1406TR03R	0.405
		Push-pull	11...30 V	XCC 1406TR03K	0.405
500 points	Pre-cabled radial L = 2 m	5 V, RS 422	4.5...5.5 V	XCC 1406TR05R	0.405
		Push-pull	11...30 V	XCC 1406TR05K	0.405
1000 points	Pre-cabled radial L = 2 m	5 V, RS 422	4.5...5.5 V	XCC 1406TR10R	0.405
		Push-pull	11...30 V	XCC 1406TR10K	0.405
1024 points	Pre-cabled radial L = 2 m	5 V, RS 422	4.5...5.5 V	XCC 1406TR11R	0.405
		Push-pull	11...30 V	XCC 1406TR11K	0.405

(1) For characteristics of the output stage type (indicated by last letter of the reference), see page 10.

(2) Anti-rotation device included with encoder.

## Environment

Encoder type		XCC 1506P●●●●	XCC 1510P●●●●	XCC 1514T●●●●
Conformity		CE		
Temperature	Operation (housing)	°C - 30...+ 100 (except XCC TSM●●X and XCC TSM●●Y: - 30...+70)		
	Storage	°C - 30...+ 85		
Degree of protection	Conforming to IEC 60529	IP 65	IP 65 (IP 67 with collar option XCC RB3)	IP 65
Vibration resistance	Conforming to IEC 60068-2-6	10 gn (f = 55...2000 Hz)		
Shock resistance	Conforming to IEC 60068-2-27	30 gn, duration 11 ms		
Resistance to electromagnetic interference	Electrostatic discharges	Conforming to IEC 61000-4-2: level 3, 8 kV air, 4 kV contact		
	Radiated electromagnetic fields (electromagnetic waves)	Conforming to IEC 61000-4-3: level 3, 10 V/m		
	Fast transients (Start/Stop interference)	Conforming to IEC 61000-4-4: level 3, 2 kV (1 kV for inputs/outputs)		
	Surge withstand	Conforming to IEC 61000-4-5: level 2, 1 kV		
Materials	Base	Aluminium		
	Housing	Zamak		
	Shaft	Stainless steel		
	Ball bearings	6000ZZ1		6803ZZ

## Mechanical characteristics

Shaft type		Ø 6, solid shaft (g7)	Ø 10 mm, solid shaft	Ø 14, through shaft (H7)
Maximum rotational speed	Continuous	9000 rpm	9000 rpm	6000 rpm
Shaft moment of inertia		<b>g.cm<sup>2</sup></b> 10	10	22
Torque		<b>N.cm</b> 0.4	0.4	0.6
Maximum load	Radial	<b>daN</b> 10	10	5
	Axial	<b>daN</b> 5	5	2

## Electrical characteristics

Connection	Connector	M23, 12-pin male connector		
Frequency		<b>kHz</b> 300		
Number of channels		3 channels: A, B, top 0 and complements $\bar{A}$ , $\bar{B}$ , $\bar{0}$		

### Encoders with type X output stage: 5 V output driver, RS 422, 4.75...30 V supply

Supply voltage		$\approx$ 4.75...30 V Max. ripple: 500 mV
Current consumption, no-load	<b>mA</b>	75 max.
Protection		Against short-circuits and reverse polarity
Output current	<b>mA</b>	40 max.
Output levels	Low level	( $I_s = 20$ mA) 0.5 V max.
	High level	( $I_s = 20$ mA) 4.5 V min.

### Encoders with type Y output stage: push-pull output driver, 5...30 V supply

Supply voltage		$\approx$ 5...30 V Max. ripple: 500 mV
Current consumption, no-load	<b>mA</b>	75 max.
Protection		Against short-circuits and reverse polarity
Output current	<b>mA</b>	40 max.
Output levels (for U supply = 30 V)	Low level	( $I_s = 20$ mA) 0.5 V max.
	High level	( $I_s = 20$ mA) V supply - 2.5 V min.

## Schemes

### Type X output stage

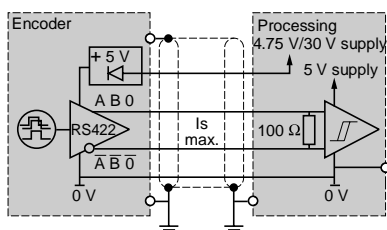

### Type Y output stage

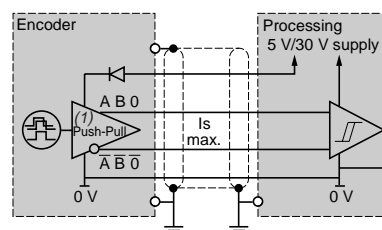

(1) RS 422 at 5 V.

105163



XCC 1506PS●●●

## Solid shaft, Ø 6 mm

Resolution	Connection method (1)	Output stage type (2)	Supply voltage	Reference	Weight kg
100 points	Connector radial M23 male	5 V, RS 422	4.75...30 V	XCC 1506PS01X	0.495
		Push-pull	5...30 V	XCC 1506PS01Y	0.495
360 points	Connector radial M23 male	5 V, RS 422	4.75...30 V	XCC 1506PS03X	0.495
		Push-pull	5...30 V	XCC 1506PS03Y	0.495
500 points	Connector radial M23 male	5 V, RS 422	4.75...30 V	XCC 1506PS05X	0.495
		Push-pull	5...30 V	XCC 1506PS05Y	0.495
1000 points	Connector radial M23 male	5 V, RS 422	4.75...30 V	XCC 1506PS10X	0.495
		Push-pull	5...30 V	XCC 1506PS10Y	0.495
1024 points	Connector radial M23 male	5 V, RS 422	4.75...30 V	XCC 1506PS11X	0.495
		Push-pull	5...30 V	XCC 1506PS11Y	0.495
2500 points	Connector radial M23 male	5 V, RS 422	4.75...30 V	XCC 1506PS25X	0.495
		Push-pull	5...30 V	XCC 1506PS25Y	0.495
5000 points	Connector radial M23 male	5 V, RS 422	4.75...30 V	XCC 1506PS50X	0.495
		Push-pull	5...30 V	XCC 1506PS50Y	0.495

105164



XCC 1510PS●●●

## Solid shaft, Ø 10 mm

Resolution	Connection method (1)	Output stage type (2)	Supply voltage	Reference	Weight kg
100 points	Connector radial M23 male	5 V, RS422	4.75...30 V	XCC 1510PS01X	0.465
		Push-pull	5...30 V	XCC 1510PS01Y	0.465
360 points	Connector radial M23 male	5 V, RS 422	4.75...30 V	XCC 1510PS03X	0.465
		Push-pull	5...30 V	XCC 1510PS03Y	0.465
500 points	Connector radial M23 male	5 V, RS 422	4.75...30 V	XCC 1510PS05X	0.465
		Push-pull	5...30 V	XCC 1510PS05Y	0.465
1000 points	Connector radial M23 male	5 V, RS 422	4.75...30 V	XCC 1510PS10X	0.465
		Push-pull	5...30 V	XCC 1510PS10Y	0.465
1024 points	Connector radial M23 male	5 V, RS 422	4.75...30 V	XCC 1510PS11X	0.465
		Push-pull	5...30 V	XCC 1510PS11Y	0.465
2500 points	Connector radial M23 male	5 V, RS 422	4.75...30 V	XCC 1510PS25X	0.465
		Push-pull	5...30 V	XCC 1510PS25Y	0.465
5000 points	Connector radial M23 male	5 V, RS 422	4.75...30 V	XCC 1510PS50X	0.465
		Push-pull	5...30 V	XCC 1510PS50Y	0.465

(1) For female connector use XZC C23FDP120S, see page 36.

(2) For characteristics of the output stage type (indicated by last letter of the reference), see page 12.

105166



XCC 1514TS●●●

## Through shaft, Ø 14 mm (1)

Resolution	Connection method (2)	Output stage type (3)	Supply voltage	Reference	Weight kg
100 points	Connector radial M23 male	5 V, RS 422	4.75...30 V	XCC 1514TS01X	0.435
		Push-pull	5...30 V	XCC 1514TS01Y	0.435
360 points	Connector radial M23 male	5 V, RS 422	4.75...30 V	XCC 1514TS03X	0.435
		Push-pull	5...30 V	XCC 1514TS03Y	0.435
500 points	Connector radial M23 male	5 V, RS 422	4.75...30 V	XCC 1514TS05X	0.435
		Push-pull	5...30 V	XCC 1514TS05Y	0.435
1000 points	Connector radial M23 male	5 V, RS 422	4.75...30 V	XCC 1514TS10X	0.435
		Push-pull	5...30 V	XCC 1514TS10Y	0.435
1024 points	Connector radial M23 male	5 V, RS 422	4.75...30 V	XCC 1514TS11X	0.435
		Push-pull	5...30 V	XCC 1514TS11Y	0.435
2500 points	Connector radial M23 male	5 V, RS 422	4.75...30 V	XCC 1514TS25X	0.435
		Push-pull	5...30 V	XCC 1514TS25Y	0.435
5000 points	Connector radial M23 male	5 V, RS 422	4.75...30 V	XCC 1514TS50X	0.435
		Push-pull	5...30 V	XCC 1514TS50Y	0.435

## Through shaft, Ø 6, 8, 10 and 12 mm (1)

Encoder type	Diameter	Reduction collar to be ordered (see page 37)
	mm	
Encoders with through shaft XCC 1514TS●●●	Ø 6	XCC R158RDA06
	Ø 8	XCC R158RDA08
	Ø 10	XCC R158RDA10
	Ø 12	XCC R158RDA12

568465

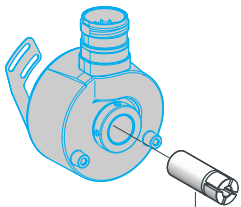

XCC R158RDA●●

(1) Anti-rotation device included with encoder.

(2) For female connector use XZC C23FDP120S, see page 36.

(3) For characteristics of the output stage type (indicated by last letter of the reference), see page 12.

Osicoder®

Ø 58 mm encoders

Parameterable versions (1)

105184



XCC 1510PSM02X

## Parameterable with solid shaft, Ø 10 mm

Resolution	Connection method (2)	Output stage type (3)	Supply voltage	Reference	Weight kg
256...4096 points	Connector radial M23 male	5 V, RS 422	4.75...30 V	XCC 1510PSM02X	0.465
		Push-pull	5...30 V	XCC 1510PSM02Y	0.465
360...5760 points	Connector radial M23 male	5 V, RS 422	4.75...30 V	XCC 1510PSM03X	0.465
		Push-pull	5...30 V	XCC 1510PSM03Y	0.465
500...8000 points	Connector radial M23 male	5 V, RS 422	4.75...30 V	XCC 1510PSM05X	0.465
		Push-pull	5...30 V	XCC 1510PSM05Y	0.465
1024...16 384 points	Connector radial M23 male	5 V, RS 422	4.75...30 V	XCC 1510PSM11X	0.465
		Push-pull	5...30 V	XCC 1510PSM11Y	0.465
5000...80 000 points	Connector radial M23 male	5 V, RS 422	4.75...30 V	XCC 1510PSM50X	0.465
		Push-pull	5...30 V	XCC 1510PSM50Y	0.465

## Parameterable with through shaft, Ø 14 mm (4)

Resolution	Connection method (2)	Output stage type (3)	Supply voltage	Reference	Weight kg
256...4096 points	Connector radial M23 male	5 V, RS 422	4.75...30 V	XCC 1514TSM02X	0.435
		Push-pull	5...30 V	XCC 1514TSM02Y	0.435
360...5760 points	Connector radial M23 male	5 V, RS 422	4.75...30 V	XCC 1514TSM03X	0.435
		Push-pull	5...30 V	XCC 1514TSM03Y	0.435
500...8000 points	Connector radial M23 male	5 V, RS 422	4.75...30 V	XCC 1514TSM05X	0.435
		Push-pull	5...30 V	XCC 1514TSM05Y	0.435
1024...16 384 points	Connector radial M23 male	5 V, RS 422	4.75...30 V	XCC 1514TSM11X	0.435
		Push-pull	5...30 V	XCC 1514TSM11Y	0.435
5000...80 000 points	Connector radial M23 male	5 V, RS 422	4.75...30 V	XCC 1514TSM50X	0.435
		Push-pull	5...30 V	XCC 1514TSM50Y	0.435

## Parameterable with through shaft, Ø 6, 8, 10 and 12 mm (4)

Encoder type	Diameter mm	Reduction collar to be ordered (see page 37)
Encoders with through shaft XCC 1514TSM●●●	Ø 6	XCC R158RDA06
	Ø 8	XCC R158RDA08
	Ø 10	XCC R158RDA10
	Ø 12	XCC R158RDA12

564465

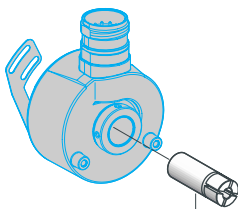

XCC R158RDA●●

(1) Parameter configuration: refer to table indicating position of dip switches on page 19.

(2) For female connector use XZC C23FDP120S, see page 36.

(3) For characteristics of the output stage type (indicated by last letter of the reference), see page 12.

(4) Anti-rotation device included with encoder.

## Environment

Encoder type		XCC 1912P●●●●	XCC 1930T●●●●
Conformity		CE	
Temperature	Operation (housing)	°C - 20...+ 80	
	Storage	°C - 30...+ 85	
Degree of protection	Conforming to IEC 60529	IP 66	IP 65
Vibration resistance	Conforming to IEC 68-2-6	10 gn (f = 10...1 kHz)	
Shock resistance	Conforming to IEC 68-2-27	30 gn, duration 11 ms	
Resistance to electromagnetic interference	Electrostatic discharges	Conforming to IEC 61000-4-2: level 3, 8 kV air; 4 kV contact	
	Radiated electromagnetic fields (electromagnetic waves)	Conforming to IEC 61000-4-3: level 3, 10 V/m	
	Fast transients (Start/Stop interference)	Conforming to IEC 61000-4-4: level 3, 2 kV (1 kV for inputs/outputs)	
	Surge withstand	Conforming to IEC 61000-4-5: level 2, 1 kV	
Materials	Base	Aluminium	
	Housing	Zamak	
	Shaft	Stainless steel	
	Ball bearings	6001ZZ	6807

## Mechanical characteristics

Shaft type		Ø 12, solid shaft (g6)	Ø 30, through shaft (H7)
Maximum rotational speed	Continuous	6000 rpm	3600 rpm
Shaft moment of inertia		<b>g.cm<sup>2</sup></b> 150	500
Torque		<b>N.cm</b> 1	2.5
Maximum load	Radial	<b>daN</b> 20	8
	Axial	<b>daN</b> 10	5

## Electrical characteristics

Connection	Connector	M23, 12-pin male connector	
Frequency		<b>kHz</b>	100
Number of channels		3 channels: A, B, top 0 and complements $\bar{A}$ , $\bar{B}$ , $\bar{0}$	

### Encoders with type R (N) output stage: 5 V output driver, RS 422, 4.5...5.5 V supply

Supply voltage		$\pm 5 \text{ V} \pm 10\%$ Max. ripple: 200 mV
Current consumption, no-load	<b>mA</b>	100 max.
Output current	<b>mA</b>	40 max.
Output levels	Low level	( $I_s = 20 \text{ mA}$ ) 0.5 V max.
	High level	( $I_s = 20 \text{ mA}$ ) V supply - 2.5 V min.

### Encoders with type K (N) output stage: push-pull output driver, 11...30 V supply

Supply voltage		$\pm 11 \text{ V} \dots 30 \text{ V}$ Max. ripple: 500 mV
Current consumption, no-load	<b>mA</b>	75 max.
Protection		Against short-circuits and reverse polarity
Output current	<b>mA</b>	40 max.
Output levels	Low level	( $I_s = 20 \text{ mA}$ ) 1.5 V max.
	High level	( $I_s = 20 \text{ mA}$ ) V supply - 3 V min.

## Schemes

### Type R (N) output stage

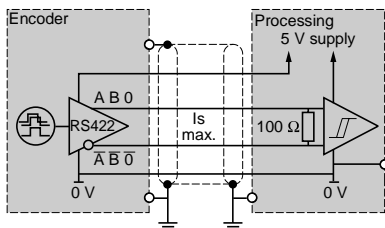

### Type K (N) output stage

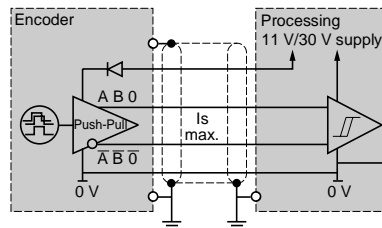

105168



XCC 1912PS●●●N

105171



XCC 1930TS●●●N

523200

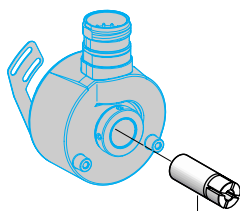

XCC R290RDP●●●N

## Solid shaft, Ø 12 mm

Resolution	Connection method (1)	Output stage type (2)	Supply voltage	Reference	Weight kg
100 points	Connector, radial M23 male	5 V, RS 422	4.5...5.5 V	XCC 1912PS01RN	1.360
		Push-pull	11...30 V	XCC 1912PS01KN	1.360
360 points	Connector, radial M23 male	5 V, RS 422	4.5...5.5 V	XCC 1912PS03RN	1.360
		Push-pull	11...30 V	XCC 1912PS03KN	1.360
500 points	Connector, radial M23 male	5 V, RS 422	4.5...5.5 V	XCC 1912PS05RN	1.360
		Push-pull	11...30 V	XCC 1912PS05KN	1.360
1000 points	Connector, radial M23 male	5 V, RS 422	4.5...5.5 V	XCC 1912PS10RN	1.360
		Push-pull	11...30 V	XCC 1912PS10KN	1.360
1024 points	Connector, radial M23 male	5 V, RS 422	4.5...5.5 V	XCC 1912PS11RN	1.360
		Push-pull	11...30 V	XCC 1912PS11KN	1.360
2500 points	Connector, radial M23 male	5 V, RS 422	4.5...5.5 V	XCC 1912PS25RN	1.360
		Push-pull	11...30 V	XCC 1912PS25KN	1.360
3600 points	Connector, radial M23 male	5 V, RS 422	4.5...5.5 V	XCC 1912PS36RN	1.360
		Push-pull	11...30 V	XCC 1912PS36KN	1.360
5000 points	Connector, radial M23 male	5 V, RS 422	4.5...5.5 V	XCC 1912PS50RN	1.360
		Push-pull	11...30 V	XCC 1912PS50KN	1.360
10 000 points	Connector, radial M23 male	5 V, RS 422	4.5...5.5 V	XCC 1912PS00RN	1.360
		Push-pull	11...30 V	XCC 1912PS00KN	1.360

## Through shaft, Ø 30 mm (3)

Resolution	Connection method (1)	Output stage type (2)	Supply voltage	Reference	Weight kg
100 points	Connector, radial M23 male	5 V, RS 422	4.5...5.5 V	XCC 1930TS01RN	0.960
		Push-pull	11...30 V	XCC 1930TS01KN	0.960
360 points	Connector, radial M23 male	5 V, RS 422	4.5...5.5 V	XCC 1930TS03RN	0.960
		Push-pull	11...30 V	XCC 1930TS03KN	0.960
500 points	Connector, radial M23 male	5 V, RS 422	4.5...5.5 V	XCC 1930TS05RN	0.960
		Push-pull	11...30 V	XCC 1930TS05KN	0.960
1000 points	Connector, radial M23 male	5 V, RS 422	4.5...5.5 V	XCC 1930TS10RN	0.960
		Push-pull	11...30 V	XCC 1930TS10KN	0.960
1024 points	Connector, radial M23 male	5 V, RS 422	4.5...5.5 V	XCC 1930TS11RN	0.960
		Push-pull	11...30 V	XCC 1930TS11KN	0.960
2500 points	Connector, radial M23 male	5 V, RS 422	4.5...5.5 V	XCC 1930TS25RN	0.960
		Push-pull	11...30 V	XCC 1930TS25KN	0.960
3600 points	Connector, radial M23 male	5 V, RS 422	4.5...5.5 V	XCC 1930TS36RN	0.960
		Push-pull	11...30 V	XCC 1930TS36KN	0.960
5000 points	Connector, radial M23 male	5 V, RS 422	4.5...5.5 V	XCC 1930TS50RN	0.960
		Push-pull	11...30 V	XCC 1930TS50KN	0.960
10 000 points	Connector, radial M23 male	5 V, RS 422	4.5...5.5 V	XCC 1930TS00RN	0.960
		Push-pull	11...30 V	XCC 1930TS00KN	0.960

## Through shaft, Ø 12, 20 and 25 mm (3)

Encoder type	Diameter mm	Reduction collar to be ordered (see page 37)
Encoders with through shaft XCC 1930TS●●●●N	Ø 12	XCC R290RDP12
	Ø 20	XCC R290RDP20
	Ø 25	XCC R290RDP25

(1) For female connector use XZC C23FDP120S, see page 36.

(2) For characteristics of the output stage type (indicated by last letters of the reference), see page 16.

(3) Anti-rotation device included with encoder.

## Ø 40 mm encoders

XCC 1406PR●●●N

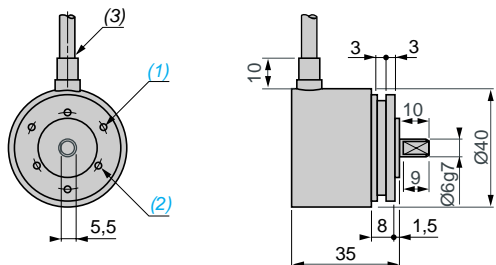

- (1) 3 holes M3 x 0.45 at 120° on 28 PCD, depth: 6 mm.
- (2) 3 holes M3 x 0.45 at 120° on 24 PCD, depth: 6 mm.
- (3) Ø 6 cable, length 2 m, minimum bend radius: 30 mm.

XCC 1406TR●●●N

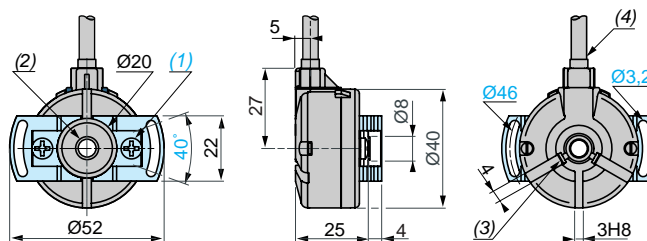

- (1) 2 M4 holes at 120° for cross-headed screws on 30 PCD, depth: 6 mm.
- (2) Through shaft, Ø 6 (H7).
- (3) 2 M2 x 3 flat cross-headed locking screws.
- (4) Ø 6 cable, length 2 m, minimum bend radius: 30 mm.

## Ø 58 mm encoders

XCC 1506PS●●X, XCC 1506PS●●Y

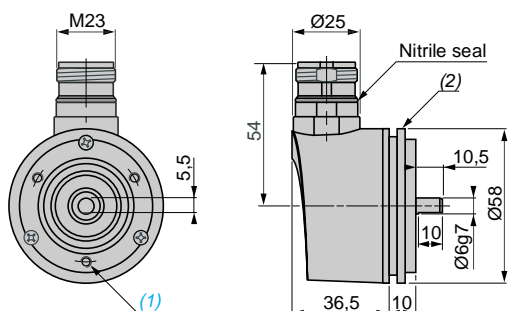

- (1) 3 holes M3 x 4 at 120° on 42 PCD, depth: 10 mm.
- (2) Collar XCC RB1 mounted.

XCC 1510PS●●X, 1510PS●●Y / XCC 1510PSM●●X, 1510PSM●●Y

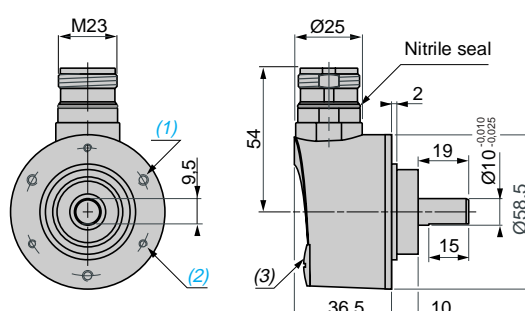

- (1) 3 M4 holes at 120° on 48 PCD, depth: 8 mm.
- (2) 3 M3 holes at 120° on 48 PCD, depth: 8 mm.
- (3) Blanking plug, for encoders XCC 1510PSM●●X and 1510PSM●●Y only.

XCC 1514TS●●X, 1514TS●●Y / XCC 1514TSM●●X, 1514TSM●●Y

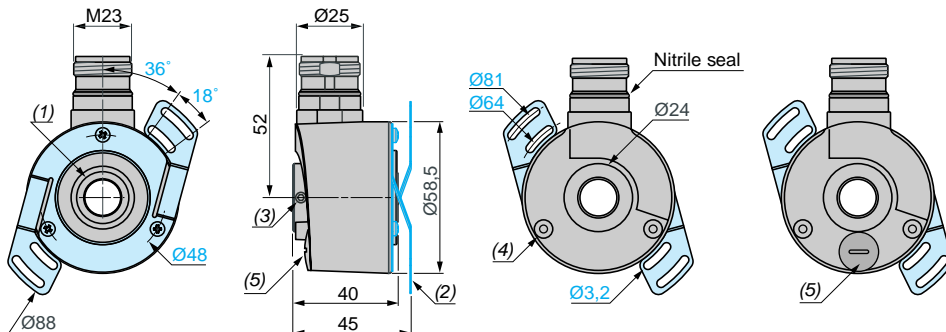

- (1) Through shaft, Ø 14 (H7).
- (2) Flexible mounting kit, 1 x XCC RF5N mounted.
- (3) 2 HC M4 x 4 locking screws.
- (4) Hole for M3 x 6 self-threading screw.
- (5) Blanking plug, for encoders XCC 1514TSM●●X and 1514TSM●●Y only.

## Ø 90 mm encoders

XCC 1912PS●●●N

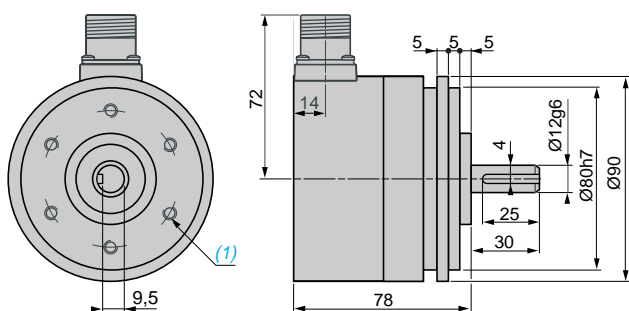

- (1) 6 holes M6 x 1 at 120° on 60 PCD, depth: 12 mm max.

XCC 1930TS●●●N

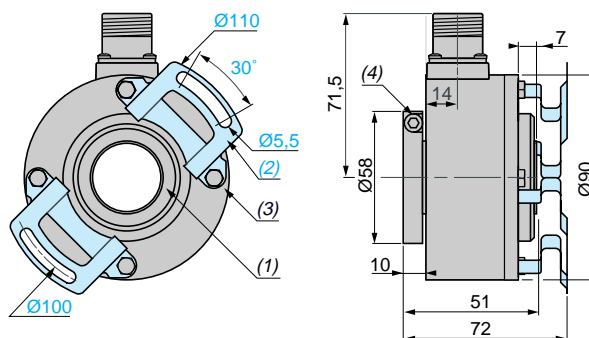

- (1) Through shaft, Ø 30 (H7).
- (2) Anti-rotation device, 1 x XCC RF9N, mounted.
- (3) 4 M5 x 6 on 78 PCD.
- (4) 1 CHC M5 x 12 stainless steel A2 locking screw.

## Pre-cabled version encoders

8 x 0.14 mm<sup>2</sup> shielded cable connections for Ø 40 encoders

Wire colour	BN	RD	VT	BU	YE	OG	GN	BK
Signal	A	+V	0	0	B	B	A	0V
Supply								

BN = Brown  
 RD = Red  
 VT = Violet  
 BU = Blue  
 YE = Yellow  
 OG = Orange  
 GN = Green  
 BK = Black

**Note:** in environments subject to electrical interference, it is recommended to earth the encoder base using one of the fixing screws.

## Connector version encoders

M23, 12-pin connector connections

Male connector on encoder (pin view)

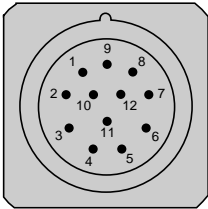

Pin number	1	2	3	4	5	6	7	8	9	10	11	12
Signal	A	+V	0	0	B	B	R	A	R	0V	0V	+V
Supply												

**Note:** in environments subject to electrical interference, it is recommended to earth the encoder base using one of the fixing screws.  
 R = reserved, do not connect.

## Resolutions

Resolutions for parameterable Ø 58 mm encoders XCC 1510PSM●●● and XCC 1514TSM●●●

Simple multiplication of the basic resolution of the disc using dip switches (1)  
 (Plastic Ø 2.5 screwdriver recommended).

The factory setting is for factor X1.

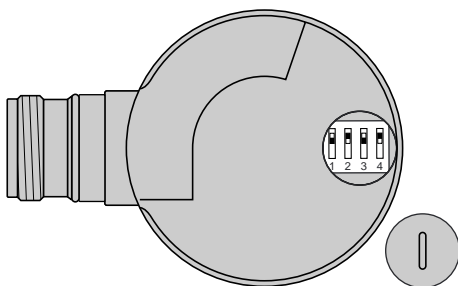

Interpolation factor	Basic resolution	Position of dip switches			
		1	2	3	4
Counting Speed	256 360 500 1024 5000				
<b>x 1</b>	<b>x 1</b>	256 360 500 1024 5000	<input type="checkbox"/>	<input type="checkbox"/>	<input type="checkbox"/>
<b>x 2</b>	<b>x 2</b>	512 720 1000 2048 10 000	<input type="checkbox"/>	<input type="checkbox"/>	<input type="checkbox"/>
<b>x 3</b>	<b>x 3</b>	768 1080 1500 3072 15 000	<input type="checkbox"/>	<input type="checkbox"/>	<input type="checkbox"/>
<b>x 4</b>	<b>x 4</b>	1024 1440 2000 4096 20 000	<input type="checkbox"/>	<input type="checkbox"/>	<input type="checkbox"/>
<b>x 5</b>	–	1280 1800 2500 5120 25 000	<input type="checkbox"/>	<input type="checkbox"/>	<input type="checkbox"/>
<b>x 8</b>	–	2048 2880 4000 8192 40 000	<input type="checkbox"/>	<input type="checkbox"/>	<input type="checkbox"/>
<b>x 10</b>	–	2560 3600 5000 10 240 50 000	<input type="checkbox"/>	<input type="checkbox"/>	<input type="checkbox"/>
<b>x 12</b>	–	3072 4320 6000 12 288 60 000	<input type="checkbox"/>	<input type="checkbox"/>	<input type="checkbox"/>
<b>x 16</b>	–	4096 5760 8000 16 384 80 000	<input type="checkbox"/>	<input type="checkbox"/>	<input type="checkbox"/>

(1) Setting the switches to other configurations will result in the encoder providing an unpredictable resolution.

## Environment

Encoder type		XCC 2506P●●●●●	XCC 2510P●●●●●	XCC 2514T●●●●●
Conformity		CE		
Temperature	Operation (housing)	°C - 20...+ 90		
	Storage	°C - 30...+ 95		
Degree of protection	Conforming to IEC 60529	IP 65	IP 65 (IP 67 with collar option XCC RB3)	IP 65
Vibration resistance	Conforming to IEC 60068-2-6	10 gn (f = 10...2 kHz)		
Shock resistance	Conforming to IEC 60068-2-27	30 gn, duration 11 ms		
Resistance to electromagnetic interference	Electrostatic discharges	Conforming to IEC 61000-4-2: level 3, 8 kV air; 4 kV contact		
	Radiated electromagnetic fields (electromagnetic waves)	Conforming to IEC 61000-4-3: level 3, 10 V/m		
	Fast transients (Start/Stop interference)	Conforming to IEC 61000-4-4: level 3, 2 kV (1 kV for inputs/outputs)		
	Surge withstand	Conforming to IEC 61000-4-5: level 2, 1 kV		
Materials	Base	Aluminium		
	Housing	Zamak		
	Shaft	Stainless steel		
	Ball bearings	6000ZZ1		6803ZZ

## Mechanical characteristics

Shaft type		Ø 6, solid shaft (g7)	Ø 10 mm, solid shaft	Ø 14, through shaft (H7)
Maximum rotational speed	Continuous	9000 rpm	9000 rpm	6000 rpm
Shaft moment of inertia		<b>g.cm<sup>2</sup></b> 10	10	22
Torque		<b>N.cm</b> 0.4	0.4	0.6
Maximum load	Radial	<b>daN</b> 10	10	5
	Axial	<b>daN</b> 5	5	2

## Electrical characteristics

Connection	Connector	Encoders with parallel output stage types KG (N), KB: M23, 16-pin male connector. Encoders with SSI output stage types SB (N), SG (N): M23, 12-pin male connector.		
Frequency		<b>kHz</b>	Encoders with parallel output stage types KG (N), KB: 100 kHz on LSB (Least Significant Bit) Encoders with SSI output stage types SB (N), SG (N): 100 kHz to 1 MHz clock	
<b>Encoders with type KB and KG (N) output stage: push-pull output driver, 11...30 V supply, Gray code</b>				
Supply voltage			11...30 V Max. ripple: 500 mV	
Current consumption, no-load		<b>mA</b>	100 max.	
Protection			Against short-circuits and reverse polarity	
Output current		<b>mA</b>	20 max.	
Output levels (for U supply = 30 V)	Low level		(I <sub>s</sub> = 20 mA) 0.5 V max.	
	High level		(I <sub>s</sub> = 20 mA) V supply - 2.5 V min.	

## Schemes

### Type KB and KG (N) output stage

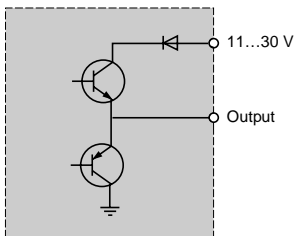

### KB and KG (N) DIRECTION input

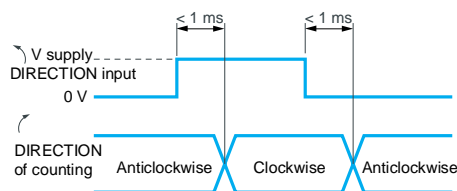

## Electrical characteristics (continued)

Encoders with type SB (N) or SG (N) output stage: SSI output without parity, 13-bit clock, 11...30 V supply, binary code (SB) or Gray code (SG)

Supply voltage		11...30 V. Max. ripple: 500 mV
Current consumption, no-load	mA	100
Protection		Against short-circuits and reverse polarity
Output level		I <sub>data</sub> = 20 mA  VOD  > 2 V

### Schemes

#### RS 422 data output

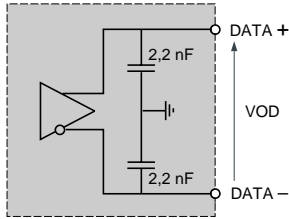

I<sub>data</sub> = 20 mA |VOD| > 2 V

#### Isolated clock input

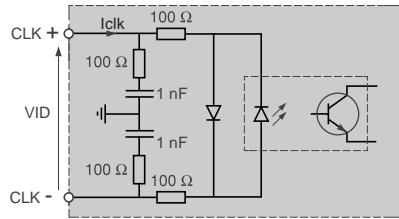

|VID| max.: 5 V  
|I<sub>clk</sub>| max.: 15 mA

#### DIRECTION input

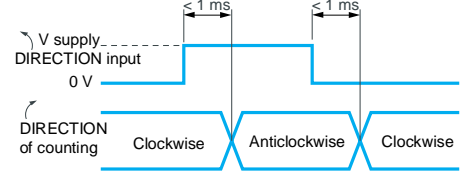

## References

105173



XCC 2506PS81●●●

Resolution	Connection method (1)	Output stage type (2)	Supply voltage	Reference	Weight kg
<b>Solid shaft, Ø 6 mm</b>					
8192 points	Connector radial M23 male	Push-pull, binary	11...30 V	XCC 2506PS81KB	0.495
		Push-pull, Gray	11...30 V	XCC 2506PS81KGN	0.495
		SSI, 13-bit, binary	11...30 V	XCC 2506PS81SBN	0.490
		SSI, 13-bit, Gray	11...30 V	XCC 2506PS81SGN	0.490
<b>Solid shaft, Ø 10 mm</b>					
8192 points	Connector radial M23 male	Push-pull, binary	11...30 V	XCC 2510PS81KB	0.465
		Push-pull, Gray	11...30 V	XCC 2510PS81KGN	0.465
		SSI, 13-bit, binary	11...30 V	XCC 2510PS81SBN	0.460
		SSI, 13-bit, Gray	11...30 V	XCC 2510PS81SGN	0.460
<b>Through shaft, Ø 14 mm (3)</b>					
8192 points	Connector radial M23 male	Push-pull, binary	11...30 V	XCC 2514TS81KB	0.435
		Push-pull, Gray	11...30 V	XCC 2514TS81KG	0.435
		SSI, 13-bit, binary	11...30 V	XCC 2514TS81SB	0.430
		SSI, 13-bit, Gray	11...30 V	XCC 2514TS81SG	0.430
<b>Through shaft, Ø 6, 8, 10 and 12 mm (3)</b>					
Encoder type	Diameter mm	Reduction collar to be ordered (see page 37)			
Encoders with through shaft XCC 2514TS81●●	Ø 6	XCC R158RDA06			
	Ø 8	XCC R158RDA08			
	Ø 10	XCC R158RDA10			
	Ø 12	XCC R158RDA12			

568465

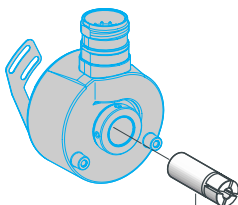

XCC R158RDA●●

(1) For female connector use:

- XZC C23FDP120S for encoders type SBN and SGN
- XZC C23FDP160S for encoders type KB and KGN, see page 36.

(2) For characteristics of the output stage type (indicated by last letters of the reference), see pages 20 and 21.

(3) Anti-rotation device included with encoder.

## Environment

Encoder type		XCC 2912P●●●●●	XCC 2930T●●●●●
Conformity		CE	
Temperature	Operation (housing)	°C - 20...+ 85	
	Storage	°C - 40...+ 85	
Degree of protection	Conforming to IEC 60529	IP 66	IP 65
Vibration resistance	Conforming to IEC 60068-2-6	10 gn (f = 10...2 kHz)	
Shock resistance	Conforming to IEC 60068-2-27	30 gn, duration 11 ms	
Resistance to electromagnetic interference	Electrostatic discharges	Conforming to IEC 61000-4-2: level 3, 8 kV air; 4 kV contact	
	Radiated electromagnetic fields (electromagnetic waves)	Conforming to IEC 61000-4-3: level 3, 10 V/m	
	Fast transients (Start/Stop interference)	Conforming to IEC 61000-4-4: level 3, 2 kV (1 kV for inputs/outputs)	
	Surge withstand	Conforming to IEC 61000-4-5: level 2, 1 kV	
Materials	Base	Aluminium	
	Housing	Zamak	
	Shaft	Stainless steel	
	Ball bearings	6001ZZ	6807

## Mechanical characteristics

Shaft type		Ø 12, solid shaft (g6)	Ø 30, through shaft (H7)
Maximum rotational speed	Continuous	6000 rpm	3600 rpm
Shaft moment of inertia		<b>g.cm<sup>2</sup></b> 150	500
Torque		<b>N.cm</b> 1	2.5
Maximum load	Radial	<b>daN</b> 20	8
	Axial	<b>daN</b> 10	5

## Electrical characteristics

Connection	Connector	<b>Encoders with parallel output stage types KB (N), KG (N):</b> M23, 16-pin male connector. <b>Encoders with SSI output stage types SB (N), SG (N):</b> M23, 12-pin male connector.	
Frequency		<b>Encoders with parallel output stage types KB (N), KG (N):</b> 100 kHz on LSB (Least Significant Bit) <b>Encoders with SSI output stage types SB (N), SG (N):</b> 100 kHz to 1 MHz clock	
<b>Encoders with type KBN or KGN output stage: push-pull output driver, 11...30 V supply, binary code (KBN) or Gray code (KGN)</b>			
Supply voltage		= 11...30 V. Max. ripple: 500 mV	
Current consumption, no-load		<b>mA</b> 100 max.	
Protection		Against short-circuits and reverse polarity	
Output current		<b>mA</b> 20 max.	
Output levels (for U supply = 30 V)	Low level	(I <sub>s</sub> = 20 mA) 0.5 V max.	
	High level	(I <sub>s</sub> = 20 mA) V supply -3 V min.	

### Schemes

#### Type KB (N) and KG (N) output stage

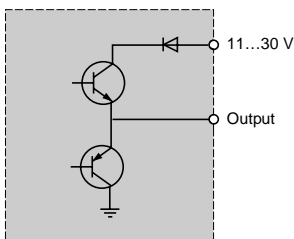

#### KB (N) and KG (N) DIRECTION input

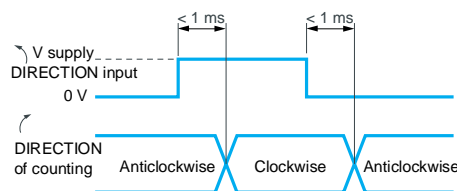

## Electrical characteristics (continued)

Encoders with type SBN or SGN output stage: SSI output without parity, 13-bit clock, 11...30 V supply, binary code (SBN) or Gray code (SGN)

Supply voltage		11...30 V Max. ripple: 500 mV
Current consumption, no-load	mA	100
Protection		Against short-circuits and reverse polarity
Output level		I <sub>data</sub> = 20 mA  VOD  > 2 V

### Schemes

#### RS 422 data output

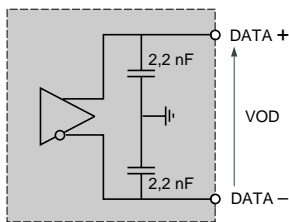

I<sub>data</sub> = 20 mA |VOD| > 2 V

#### Isolated clock input

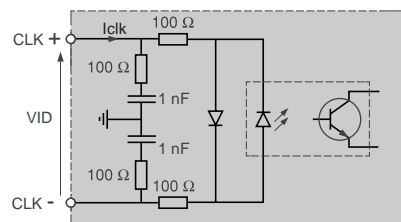

|VID| max.: 5 V  
|I<sub>clk</sub>| max.: 15 mA

#### DIRECTION input

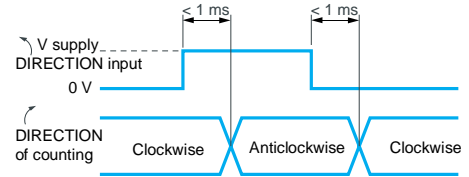

## References

105168



XCC 2912PS●●●●

105171



XCC 2930TS●●●●

523200

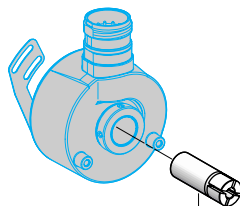

XCC R290RDP●●

Resolution	Connection method (1)	Output stage type (2)	Supply voltage	Reference	Weight kg
<b>Solid shaft, Ø 12 mm</b>					
8192 points	Connector radial M23 male	Push-pull, binary	11...30 V	XCC 2912PS81KBN	1.365
		Push-pull, Gray	11...30 V	XCC 2912PS81KGN	1.365
		SSI, 13-bit, binary	11...30 V	XCC 2912PS81SBN	1.370
		SSI, 13-bit, Gray	11...30 V	XCC 2912PS81SGN	1.370
<b>Through shaft, Ø 30 mm (3)</b>					
8192 points	Connector radial M23 male	Push-pull, binary	11...30 V	XCC 2930TS81KBN	0.975
		Push-pull, Gray	11...30 V	XCC 2930TS81KGN	0.975
		SSI, 13-bit, binary	11...30 V	XCC 2930TS81SBN	0.980
		SSI, 13-bit, Gray	11...30 V	XCC 2930TS81SGN	0.980
<b>Through shaft, Ø 12, 20 and 25 mm (3)</b>					
Encoder type	Diameter mm	Reduction collar to be ordered (see page 37)			
Encoders with through shaft XCC 2930TS81●●●	Ø 12	XCC R290RDP12			
	Ø 20	XCC R290RDP20			
	Ø 25	XCC R290RDP25			

(1) For female connectors use:

- XZC C23FDP120S for encoders type SBN and SGN
- XZC C23FDP160S for encoders type KBN and KGN, see page 36.

(2) For characteristics of the output stage type (indicated by last letters of the reference), see pages 22 and 23.

(3) Anti-rotation device included with encoder.

## Ø 58 mm encoders

XCC 2506PS81KB, XCC 2506PS81KGN, XCC 2506PS81SBN, XCC 2506PS81SGN

XCC 2510PS81KB, XCC 2510PS81KGN, XCC 2510PS81SBN, XCC 2510PS81SGN

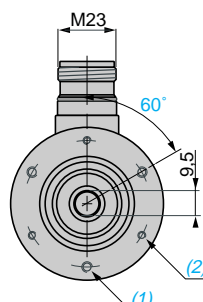
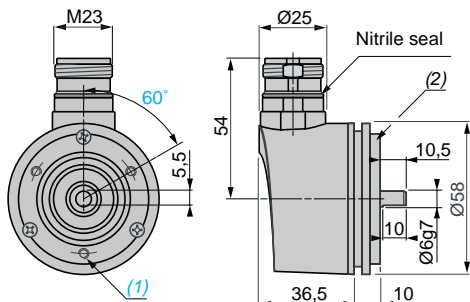

(1) 3 M4 holes at 120° on 42 PCD, depth: 10 mm.  
(2) Collar XCC RB1 mounted.

(1) 3 M4 holes at 120° on 48 PCD, depth: 8 mm.  
(2) 3 M3 holes at 120° on 48 PCD, depth: 8 mm.

## XCC 2514TS81KB, XCC 2514TS81KGN, XCC 2514TS81SB, XCC 2514TS81SG

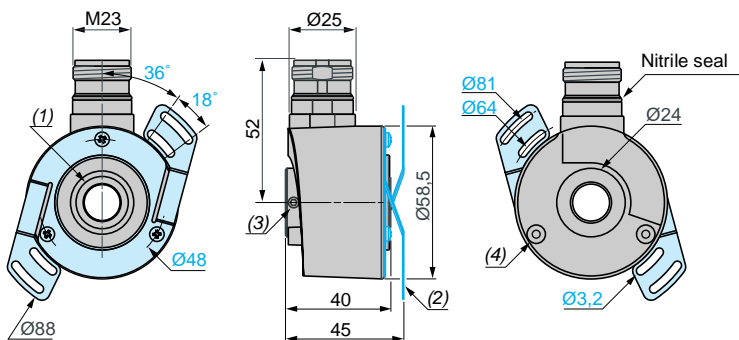

(1) Through shaft, Ø 14 (H7).  
(2) Flexible mounting kit, 1 x XCC RF5N mounted.  
(3) 2 HC M4 x 4 locking screws.  
(4) Hole for M3 x 6 self-threading screw.

## Ø 90 mm encoders

XCC 2912PS81KBN, XCC 2912PS81KGN

XCC 2930TS81SBN, XCC 2930TS81SGN

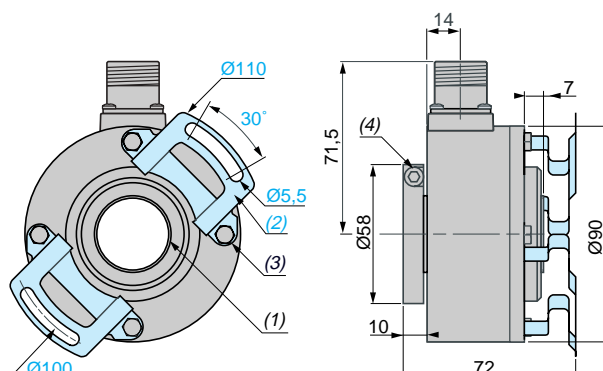
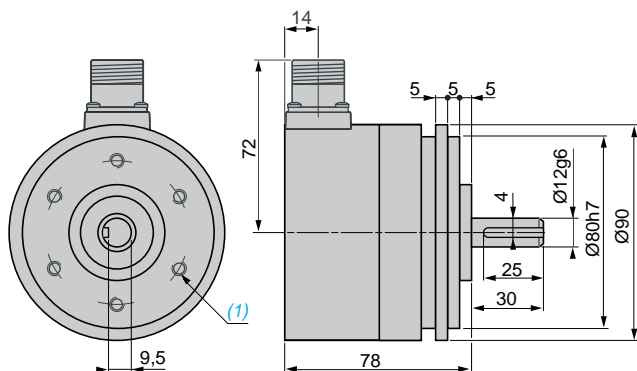

(1) 6 holes M6 x 1 at 120° on 60 PCD, depth: 12 mm max.

(1) Through shaft, Ø 30 (H7).  
(2) Anti-rotation device, 1 x XCC RF9N mounted.  
(3) 4 M5 x 6 on 78 PCD.  
(4) 1 CHC M5 x 12 stainless steel A2 locking screw.

## Connector version encoders

### Encoders type KB (N) and KG (N)

#### M23, 16-pin connector, anticlockwise connections

Male connector on encoder (pin view)

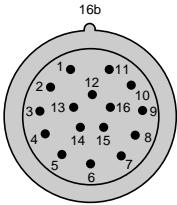

Pin number	1	2	3	4	5	6	7	8	9	10	11	12	13	14	15	16
Signal/Supply	0 V	+ V	d0	d1	d2	d3	d4	d5	d6	d7	d8	d9	d10	d11	d12	Direction (1) ↻

If a resolution less than 13 bits (8192 points) is required, only the corresponding number of bits need to be connected:

- Example:
- D5 to D12 for 8 bits (256 points)
  - D3 to D12 for 10 bits (1024 points)
  - D2 to D12 for 11 bits (2048 points)

(1) ↻ : Clockwise direction, 16 to + V.  
 ↺ : Anticlockwise direction, 16 to 0 V.

### Encoders type SB (N) and SG (N)

#### M23, 12-pin connector, anticlockwise connections

Male connector on encoder (pin view)

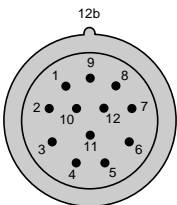

Pin number	1	2	3	4	5	6	7	8	9	10	11	12
Signal/Supply	0 V	Data +	Clk +	R	Direction R (1) ↻	R	R	+ V	R	Data -	Clk -	R

R = Reserved (do not connect).  
 (1) ↻ : Clockwise direction, 5 to 0 V.  
 ↺ : Anticlockwise direction, 5 to + V.

## Environment

Encoder type	Multiturn absolute		XCC 3506P●●●●●	XCC 3510P●●●●●	XCC 3514T●●●●●
Conformity		°C	CE		
Temperature	Operation (housing)	°C	- 20...+ 85		
	Storage	°C	- 20...+ 85		
Degree of protection	Conforming to IEC 60529		IP 65	IP 65 (IP 67 with collar option XCC RB3)	IP 65
Vibration resistance	Conforming to IEC 60068-2-6		10 gn (f = 10...2 kHz)		
Shock resistance	Conforming to IEC 60068-2-27		30 gn, duration 11 ms		
Resistance to electromagnetic interference	Electrostatic discharges		Conforming to IEC 61000-4-2: level 3, 8 kV air; 4 kV contact		
	Radiated electromagnetic fields (electromagnetic waves)		Conforming to IEC 61000-4-3: level 3, 10 V/m		
	Fast transients (Start/Stop interference)		Conforming to IEC 61000-4-4: level 3, 2 kV (1 kV for inputs/outputs)		
	Surge withstand		Conforming to IEC 61000-4-5: level 2, 1 kV		
Materials	Base		Aluminium		
	Housing		Steel		
	Shaft		Stainless steel		
	Ball bearings		6900ZZ1		6803ZZ

## Mechanical characteristics

Shaft type			Ø 6, solid shaft (g7)	Ø 10 mm, solid shaft	Ø 14, through shaft (H7)
Maximum rotational speed	Continuous		6000 rpm		
Shaft moment of inertia		g.cm <sup>2</sup>	10		22
Torque		N.cm	0.4		0.6
Maximum load	Radial	daN	10		5
	Axial	daN	5		2

## Electrical characteristics

Connection	Connector		Encoders with SSI output stage types SB (N), SG (N): M23, 12-pin male connector		
Frequency			Encoders with SSI output stage types SB (N), SG (N): 100 to 500 kHz clock		
Supply voltage			= 11...30 V. Max. ripple: 500 mV		
Current consumption, no-load		mA	100 max.		
Protection			Against short-circuits and reverse polarity		
Output level			I <sub>data</sub> = 20 mA  VOD  > 2 V		

### Schemes

#### RS 422 data output

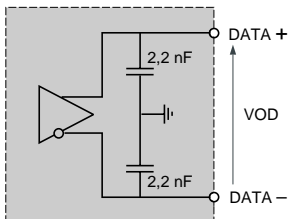

I<sub>data</sub> = 20 mA |VOD| > 2 V

#### DIRECTION input

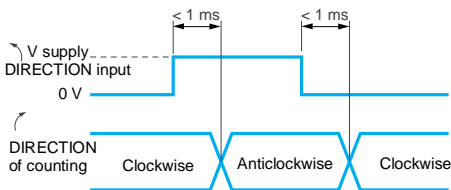

#### Isolated clock input

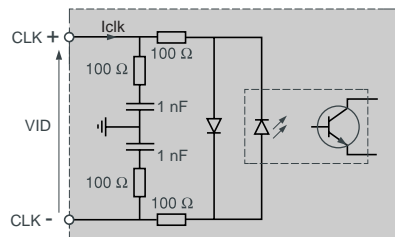

|VID| max.: 5 V  
|I<sub>clk</sub>| max.: 15 mA

#### Input stage - Reset to zero

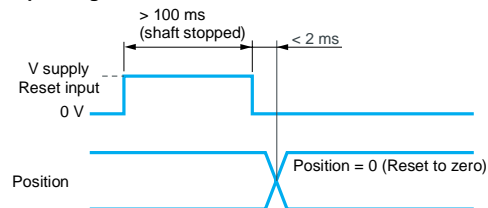

105174



XCC 3506PS84SBN

### Ø 58 mm multiturn absolute encoders with SSI output convertible to parallel output

The SSI versions can be converted to a parallel version using the deserialisation connecting cable XCC RM23SUB37●●, see pages 33 and 36.

#### Solid shaft, Ø 6 mm

Resolution	Connection method (1)	Output stage type (2)	Supply voltage	Reference	Weight kg
4096 points 8192 turns	Connector radial M23 male	SSI, 25-bit, Gray	11...30 V	XCC 3506PS48SGN	0.725
8192 points 4096 turns	Connector radial M23 male	SSI, 25-bit, binary	11...30 V	XCC 3506PS84SBN	0.725
		SSI, 25-bit, Gray	11...30 V	XCC 3506PS84SGN	0.725

#### Solid shaft, Ø 10 mm

Resolution	Connection method (1)	Output stage type (2)	Supply voltage	Reference	Weight kg
4096 points 8192 turns	Connector radial M23 male	SSI, 25-bit, Gray	11...30 V	XCC 3510PS48SGN	0.685
8192 points 4096 turns	Connector radial M23 male	SSI, 25-bit, binary	11...30 V	XCC 3510PS84SBN	0.685
		SSI, 25-bit, Gray	11...30 V	XCC 3510PS84SGN	0.685

#### Through shaft, Ø 14 mm (3)

Resolution	Connection method (1)	Output stage type (2)	Supply voltage	Reference	Weight kg
8192 points 4096 turns	Connector radial M23 male	SSI, 25-bit, binary	11...30 V	XCC 3514TS84SB	0.655
		SSI, 25-bit, Gray	11...30 V	XCC 3514TS84SG	0.655

#### Through shaft, Ø 6, 8, 10 and 12 mm (3)

Encoder type	Diameter mm	Reduction collar to be ordered (see page 37)
Encoders with through shaft Ø 6 XCC 3514TS84●●●	Ø 6	XCC R158RDA06
	Ø 8	XCC R158RDA08
	Ø 10	XCC R158RDA10
	Ø 12	XCC R158RDA12

(2) For female connector use XZC C23FDP120S, see page 36.

(3) For characteristics of the output stage type (indicated by last letters of the reference), see page 26.

(4) Anti-rotation device included with encoder.

566465

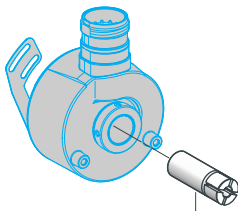

XCC R158RDA●●●

## Environment

Encoder type		XCC 3912P●●●●●	XCC 3930T●●●●●
Conformity		CE	
Temperature	Operation (housing)	°C	- 20...+ 85
	Storage	°C	- 30...+ 85
Degree of protection	Conforming to IEC 60529	IP 66	IP 65
Vibration resistance	Conforming to IEC 60068-2-6	10 gn (f = 10...2 kHz)	
Shock resistance	Conforming to IEC 60068-2-27	30 gn, duration 11 ms	
Resistance to electromagnetic interference	Electrostatic discharges	Conforming to IEC 61000-4-2: level 3, 8 kV air; 4 kV contact	
	Radiated electromagnetic fields (electromagnetic waves)	Conforming to IEC 61000-4-3: level 3, 10 V/m	
	Fast transients (Start/Stop interference)	Conforming to IEC 61000-4-4: level 3, 2 kV (1 kV for inputs/outputs)	
	Surge withstand	Conforming to IEC 61000-4-5: level 2, 1 kV	
Materials	Base	Aluminium	
	Housing	Zamak	
	Shaft	Stainless steel	
	Ball bearings	6001ZZ	6807ZZ

## Mechanical characteristics

Shaft type		Ø 12, solid shaft (g6)	Ø 30, through shaft (H7)
Maximum rotational speed	Continuous	6000 rpm	3600 rpm
Shaft moment of inertia		<b>g.cm<sup>2</sup></b> 150	56
Torque		<b>N.cm</b> 1	0.8
Maximum load	Radial	<b>daN</b> 20	8
	Axial	<b>daN</b> 10	5

## Electrical characteristics

Connection	Connector	Encoders with SSI output stage types SB (N), SG (N): M23, 12-pin male connector	
Frequency		Encoders with SSI output stage types SB (N), SG (N): 100 to 500 kHz clock	
Encoders with type SBN or SGN (Gray) output stage: SSI output without parity, 25-bit clock, 11...30 V supply, binary code (SB) or Gray code (SG)			
Supply voltage		11...30 V Max. ripple: 500 mV	
Current consumption, no-load		<b>mA</b>	100 max.
Protection		Against short-circuits and reverse polarity	
Output level		I <sub>data</sub> = 20 mA  VOD  > 2 V	

### Schemes

#### RS 422 data output

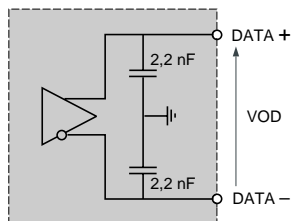

I<sub>data</sub> = 20 mA |VOD| > 2 V

#### Isolated clock input

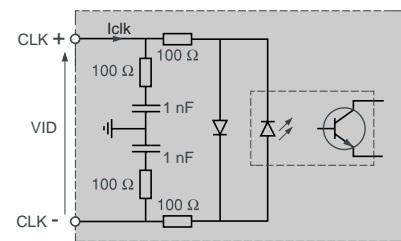

|VID| max.: 5 V  
|I<sub>clk</sub>| max.: 15 mA

#### DIRECTION input

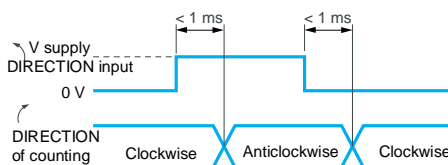

#### Input stage - Reset to zero

##### XCC 3912P●●●●●

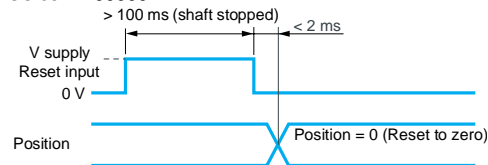

##### XCC 3930T●●●●●

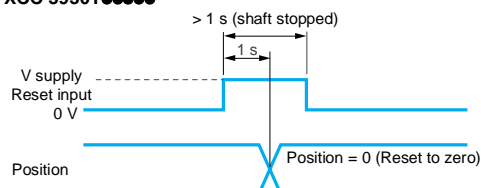

### Ø 90 mm multiturn absolute encoders with SSI output convertible to parallel output

The SSI versions can be converted to a parallel version using the deserialisation connecting cable XCC RM23SUB37●●, see pages 33 and 36.

105178



XCC 3912PS●●●●

#### Solid shaft, Ø 12 mm

Resolution	Connection method (1)	Output stage type (2)	Supply voltage	Reference	Weight kg
8192 points 4096 turns	Connector radial M23 male	SSI, 25-bit, binary	11...30 V	XCC 3912PS84SBN	1.840
		SSI, 25-bit, Gray	11...30 V	XCC 3912PS84SGN	1.840

105179



XCC 3930TS●●●●

#### Through shaft, Ø 30 mm (3)

Resolution	Connection method (1)	Output stage type (2)	Supply voltage	Reference	Weight kg
8192 points 4096 turns	Connector radial M23 male	SSI, 25-bit, binary	11...30 V	XCC 3930TS84SBN	1.060
		SSI, 25-bit, Gray	11...30 V	XCC 3930TS84SGN	1.060

523200

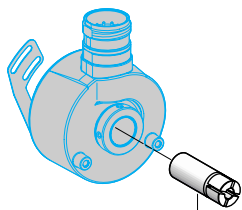

XCC R390RDP●●

#### Through shaft, Ø 16, 20 and 25 mm (3)

Encoder type	Diameter mm	Reduction collar to be ordered (see page 37)
Encoders with through shaft XCC 3930TS84●●●●	Ø 16	XCC R390RDP16
	Ø 20	XCC R390RDP20
	Ø 25	XCC R390RDP25

(5) For female connector use XZC C23FDP120S, see page 36.

(6) For characteristics of the output stage type (indicated by last letters of the reference), see page 28.

(7) Anti-rotation device included with encoder.

**Ø 58 mm encoders**

XCC 3506PS84SBN, XCC 3506PS84SGN

XCC 3510PS84SBN, XCC 3510PS84SGN

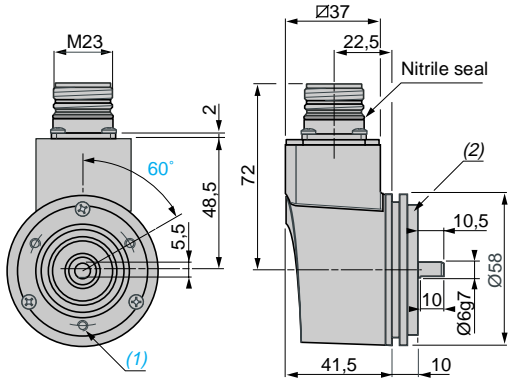

(1) 3 M4 holes at 120° on 42 PCD, depth: 10 mm.  
(2) Collar XCC RB1 mounted.

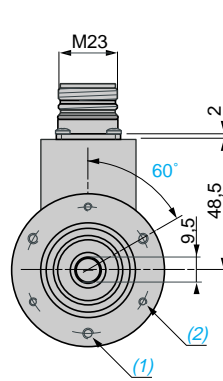

(1) 3 M4 holes at 120° on 48 PCD, depth: 8 mm.  
(2) 3 M3 holes at 120° on 48 PCD, depth: 8 mm.

**XCC 3514TS84SB, XCC 3514TS84SG**

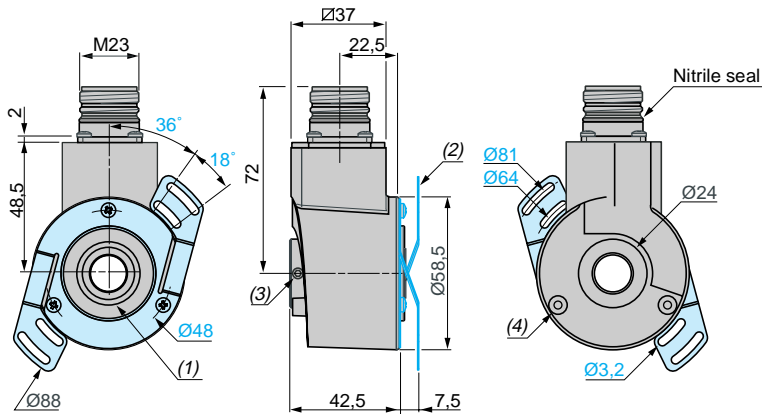

(1) Through shaft, Ø 14 (H7).  
(2) Flexible mounting kit, 1 x XCC RF5N mounted.  
(3) 2 HC M4 x 4 locking screws.  
(4) Hole for M3 x 6 self-threading screw.



## Connector version encoders

Encoders with SSI output (types SBN and SGN)  
 M23, 12-pin connector, anticlockwise connections

Male connector on encoder (pin view)

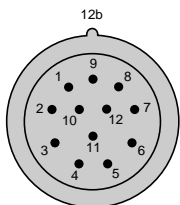

Twisted cable pairs + general shielding must be used.

Pin number	1	2	3	4	5	6	7	8	9	10	11	12
Signal/Supply	0 V	Data +	Clk +	R	Direction	Reset	R	+ V	R	Data -	Clk -	R

R = Reserved (do not connect).  
 (1) ↻ : Clockwise direction, ↺ : Anticlockwise direction.

### Selection of code progression direction

The DIRECTION input enables the code progression to match the rotational direction of the encoder shaft (clockwise or anticlockwise).

Clockwise direction: connect pin 5 to 0 V.

Anticlockwise direction: connect pin 5 to + V.

### Reset to zero

The RESET input enables the encoder to be set to the zero position.

It is actuated by applying an 11...30 V d.c. supply to pin 6, whilst the shaft is stopped, for the following times:

- over 100 ms for XCC 3506, XCC 3510 and XCC 3912,
- over 1 s for XCC 3930T.

Following a reset to zero, pin 6 must be reconnected to 0 V.

**Note:** in environments subject to electrical interference, it is recommended to earth the encoder base using one of the fixing screws.

## Pre-cabled version multiturn absolute encoders

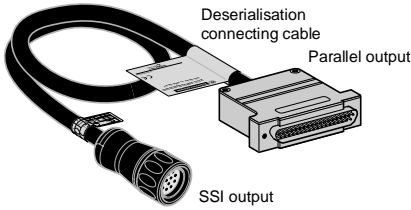

The deserialisation connecting cable XCC RM23SUB37 enables conversion, by simple connection, of encoders XCC 35●● and XCC 39●● with SSI output to parallel output.

### Characteristics

Supply	11 to 30 V
Encoder input/output	Levels RS 422
Parallel outputs	Push-pull protection against short-circuits
Operating temperature	0 to 50 °C

36 x 0.14 mm<sup>2</sup> shielded cable and SUB-D 37-pin end connector connections

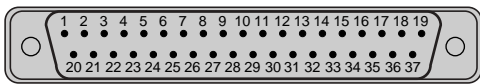

Male connector (pin view)

Pin number	Signal	Encoders 4096 points 8192 turns	Encoders 8192 points 4096 turns
1	2 <sup>0</sup> (LSB)	Resolution per revolution	Resolution per revolution
2	2 <sup>1</sup>		
3	2 <sup>2</sup>		
4	2 <sup>3</sup>		
5	2 <sup>4</sup>		
6	2 <sup>5</sup>		
7	2 <sup>6</sup>		
8	2 <sup>7</sup>		
9	2 <sup>8</sup>		
10	2 <sup>9</sup>		
11	2 <sup>10</sup>		
12	2 <sup>11</sup>		
13	2 <sup>12</sup>		
14	2 <sup>13</sup>	Number of revolutions	Number of revolutions
15	2 <sup>14</sup>		
16	2 <sup>15</sup>		
17	2 <sup>16</sup>		
18	2 <sup>17</sup>		
19	2 <sup>18</sup>		
20	2 <sup>19</sup>		
21	2 <sup>20</sup>		
22	2 <sup>21</sup>		
23	2 <sup>22</sup>		
24	2 <sup>23</sup>		
25	2 <sup>24</sup> (MSB)		
26	R		
27	Reset to zero		
28	Select		
29	Latch		
30	Direction (1) ⤴ ⤵		
31, 32, 33, 34, 35	R		
36	+ V		
37	0 V		

### Selection of code progression direction

The DIRECTION input enables the code progression to match the rotational direction of the encoder shaft (clockwise or anticlockwise).

Clockwise direction: connect pin 30 to an 11...30 V d.c. supply.  
Anticlockwise direction: connect pin 30 to 0 V.

### Reset to zero

The RESET input enables the encoder to be set to the zero position. It is actuated by applying an 11...30 V d.c. supply to pin 27 for more than 1 second.

### Encoder selection

The SELECT input enables encoder selection when several units are connected in parallel on the same data bus.  
Encoder selected: apply 0 V potential to pin 28.  
Encoder not selected: apply 11...30 V d.c. to pin 28.

### Data locking

The LATCH input, particularly useful for high speed applications, enables the freezing of the encoder data output whilst reading the code.

Function not actuated: apply 0 V potential to pin 29.  
Function actuated: apply 11...30 V d.c. to pin 29.

R = Reserved, do not connect

(1) ⤴ : clockwise direction, ⤵ : anticlockwise direction.

**Note:** in environments subject to electrical interference, it is recommended to earth the encoder base using one of the fixing screws.

## Schemes

### LATCH input

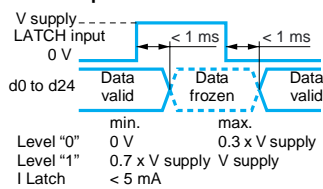

### PUSH-PULL

Supply: 11 to 30 V  
Max. ripple: 500 mV  
Protection against reverse polarity  
Max. no-load consumption: 50 mA (30 mA typical on 24 V)

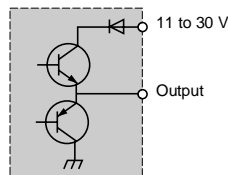

### SELECT input

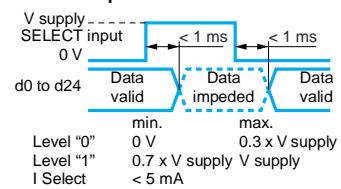

### DIRECTION input

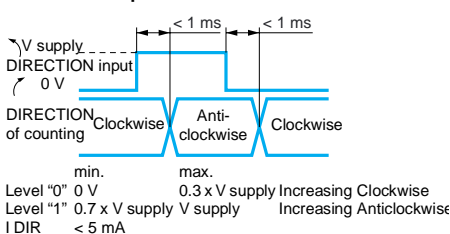

### Input stage - Reset to zero

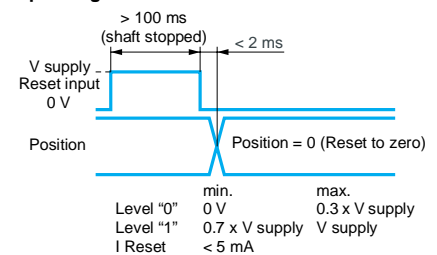

**Note:** do not neglect the LATCH and SELECT inputs. Connecting them to 0 V makes the outputs active.

**Shaft couplings with spring (1)**

<b>Maximum torque</b>	<b>N.cm</b>	300
<b>Maximum angular misalignment</b>		5°
<b>Maximum radial misalignment</b>	<b>mm</b>	± 1.5
<b>Materials</b>	Collars	Zamak
	Spring	Nickel plated steel
<b>Compression/Expansion</b>	<b>mm</b>	± 1 max.

**Homokinetic (flexible) shaft couplings with bellows**

<b>Maximum torque</b>	<b>N.cm</b>	80
<b>Maximum angular misalignment</b>		4°
<b>Maximum lateral misalignment</b>	<b>mm</b>	± 0.3
<b>Maximum axial misalignment</b>	<b>mm</b>	± 0.5
<b>Materials</b>	Bellows	Stainless steel
	Fixing collar	Aluminium
	Screws	Stainless steel

**Elastic monobloc shaft couplings**

<b>Maximum torque</b>	<b>N.cm</b>	20
<b>Maximum angular misalignment</b>		± 2.5°
<b>Maximum radial misalignment</b>	<b>mm</b>	± 0.3
<b>Compression/Expansion</b>	<b>mm</b>	± 2 max.
<b>Materials</b>		Glass fibre reinforced polyamide

(1) Not recommended for resolutions higher than 500 points.

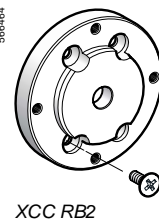
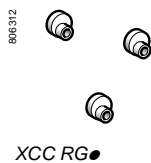
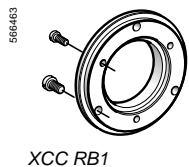
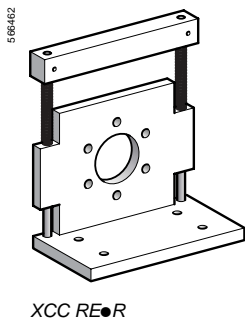
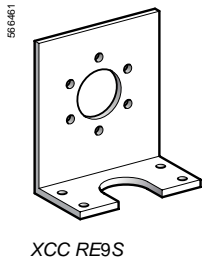

## References

### Shaft couplings (for encoders with solid shaft)

Type	Bore diameter (encoder side)	Bore diameter (machine side)	Reference	Weight kg	
With spring (1)	6 mm	6 mm	XCC RAR0606	0.125	
		8 mm	XCC RAR0608	0.125	
		10 mm	XCC RAR0610	0.125	
		12 mm	XCC RAR0612	0.120	
		14 mm	XCC RAR0614	0.120	
		16 mm	XCC RAR0616	0.120	
	10 mm	8 mm	XCC RAR1008	0.120	
		10 mm	XCC RAR1010	0.120	
		12 mm	XCC RAR1012	0.110	
		14 mm	XCC RAR1014	0.110	
		16 mm	XCC RAR1016	0.105	
		12 mm	8 mm	XCC RAR1208	0.110
12 mm	XCC RAR1212		0.110		
14 mm	XCC RAR1214		0.105		
16 mm	XCC RAR1216		0.100		
Homokinetic (flexible) with bellows	6 mm		6 mm	XCC RAS0606	0.020
			8 mm	XCC RAS0608	0.020
		10 mm	XCC RAS0610	0.020	
		12 mm	XCC RAS0612	0.015	
	10 mm	8 mm	XCC RAS1008	0.015	
		10 mm	XCC RAS1010	0.015	
		12 mm	XCC RAS1012	0.015	
		12 mm	XCC RAS1208	0.010	
	12 mm	8 mm	XCC RAS1208	0.010	
		12 mm	XCC RAS1212	0.010	
	Elastic, monobloc	6 mm	6 mm	XCC RAE0606	0.010

### Anti-rotation devices (for encoders with through shaft)

Description	Features	For encoders	Reference	Weight kg
Flexible mounting kit	Set of 2 flexible fixings + screws	Ø 40 XCC 1406T	XCC RF4	0.010
	1 flexible fixing + screws	Ø 58 XCC 15●●T, XCC 25●●T, XCC 3514T	XCC RF5N	0.020
	Set of 2 flexible fixings + screws	Ø 90 XCC 19●●T, XCC 29●●T, XCC 39●●T	XCC RF9	0.030

### Mounting and fixing accessories (for encoders with solid shaft)

Description	For encoders	Reference	Weight kg
Set of 3 eccentric clamps + 3 fixing screws (2) + 3 washers	XCC 15●●P, XCC 25●●P, XCC 35●●P	XCC RG5	0.010
	XCC 1912P, XCC 2912P, XCC 3912P	XCC RG9	0.030
Plain brackets for Ø 58	XCC 1510P, XCC 2510P, XCC 3510P	XCC RE5SN	0.130
Plain brackets for Ø 90	XCC 1912P, XCC 2912P, XCC 3912P	XCC RE9SN	0.290
Brackets with play compensator	XCC 1510P, XCC 2510P, XCC 3510P	XCC RE5RN	0.345
	XCC 1912P, XCC 2912P, XCC 3912P	XCC RE9RN	0.890
Collar for synchro mounting, for Ø 58	XCC 1510P, XCC 2510P, XCC 3510P	XCC RB1	0.040
Substitution interface collar for Ø 90	XCC 1912P, XCC 2912P, XCC 3912P	XCC RB2	0.175
IP 67 sealed collar for Ø 58	XCC 1510P, XCC 2510P, XCC 3510P	XCC RB3	0.030

(1) Not recommended for resolutions higher than 500 points.

(2) 3 M3 x 12 screws for XCC RG5, 3 M4 x 25 screws for XCC RG9.

## Cables

Description	For encoders	No. of wires/ c.s.a.	Ø mm	Reference	Weight kg
<b>Shielded cables with twisted pairs</b> Length: 100 m UL/CSA	Incremental	10 wires/ 0.14 mm <sup>2</sup>	6	<b>XCC RX10</b>	5.000
	Absolute, single turn //	16 wires/ 0.14 mm <sup>2</sup>	6.8	<b>XCC RX16</b>	5.600
	Absolute, multiturn //	36 wires/ 0.14 mm <sup>2</sup>	9.2	<b>XCC RX36</b>	13.500
	Absolute, single turn and multiturn SSI	1 pair of 0.50 mm <sup>2</sup> wires and 3 pairs of 0.14 mm <sup>2</sup> wires	8.6	<b>XCC RXS8</b>	11.750

## Connectors

Description	For use with	Number of pins	Type	Reference	Weight kg
<b>M23 female connectors</b>	Encoders Incremental, absolute SSI	12	Straight	<b>XZC C23FMDP120S</b>	0.040
	Absolute encoders, 16 single turn parallel	16	Straight	<b>XZC C23FMDP160S</b>	0.040
<b>Connector kit</b> 1 female + 1 male	SSI jumper cable or incremental encoders	–	–	<b>XZC C23FMDP120S</b>	0.090
<b>SUB-D 37-pin female connector</b>	Absolute encoders, 37 multiturn parallel	–	Straight	<b>XZC CHFDM370S</b>	0.115

## Pre-wired connectors

Description	Number of wires	Cable length	Reference	Weight kg
<b>M23 F straight</b>	8 wires Absolute SSI	2 m	<b>XCC PM23122L2</b>	0.190
		5 m	<b>XCC PM23122L5</b>	0.470
		10 m	<b>XCC PM23122L10</b>	0.900
	10 wires Incremental	2 m	<b>XCC PM23121L2</b>	0.160
		5 m	<b>XCC PM23121L5</b>	0.330
		10 m	<b>XCC PM23121L10</b>	0.620
	16 wires Absolute single turn //	2 m	<b>XCC PM23161L2</b>	0.175
		5 m	<b>XCC PM23161L5</b>	0.415
		10 m	<b>XCC PM23161L10</b>	0.790

## Deserialisation jumper cables (1)

Description	Type	Reference	Weight kg
<b>M23 F - SUB-D37 M jumper cables, straight M23, length 0.5 m</b>	SSI Gray//Gray PNP (PG)	<b>XCCRM23SUB37PG</b>	0.225
	SSI Gray//Gray NPN (NG)	<b>XCC RM23SUB37NG</b>	0.225
	SSI Binary//Binary PNP (PB)	<b>XCC RM23SUB37PB</b>	0.225
	SSI Binary//Binary NPN (NB)	<b>XCC RM23SUB37NB</b>	0.225

(1) See General, page 5 and Connections, page 33.

566466

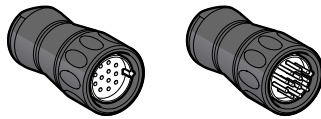

XZC C23FMDP120S

566467

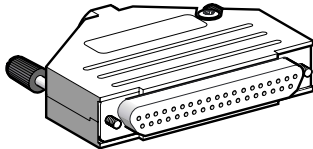

XZC CHFDM1370S

105194



XCC PM23161L2

105193



XCC RM23SUB37PG

105188



XCC R158RDA08

105180



XCC R290RDP20

## Reduction collars for encoders with through shaft

Description	For use with	Reduction	Reference	Weight kg
Reduction collars	Incremental encoders Ø 58	14 to 6	XCC R158RDA06	0.015
	Absolute single turn encoders Ø 58			
	Absolute multiturn encoders Ø 58	14 to 8	XCC R158RDA08	0.010
		14 to 10	XCC R158RDA10	0.010
		14 to 12	XCC R158RDA12	0.010
	Incremental encoders Ø 90	30 to 12	XCC R290RDP12	0.060
	Absolute single turn encoders Ø 90			
		30 to 20	XCC R290RDP20	0.030
		30 to 25	XCC R290RDP25	0.020
	Absolute multiturn encoders Ø 90	30 to 16	XCC R390RDP16	0.040
		30 to 20	XCC R390RDP20	0.020
		30 to 25	XCC R390RDP25	0.020

## Shaft couplings

### XCC RAR●●●●

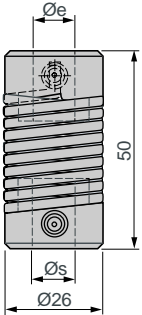

XCC	Ø e	Ø s
RAR0606	6	6
RAR0608	6	8
RAR0610	6	10
RAR0612	6	12
RAR0614	6	14
RAR0616	6	16
RAR1008	10	8
RAR1010	10	10
RAR1012	10	12
RAR1014	10	14
RAR1016	10	16
RAR1208	12	8
RAR1212	12	12
RAR1214	12	14
RAR1216	12	16

### XCC RAS●●●●

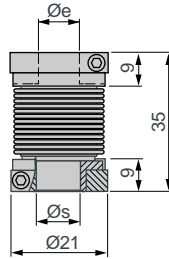

XCC	Ø e	Ø s
RAS0606	6	6
RAS0608	6	8
RAS0610	6	10
RAS0612	6	12
RAS1008	10	8
RAS1010	10	10
RAS1012	10	12
RAS1208	12	8
RAS1212	12	12

### XCC RAE0606

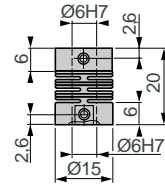

## Anti-rotation devices (flexible mounting kit)

### XCC RF4

Mounting on Ø 40 mm encoder XCC 1406T

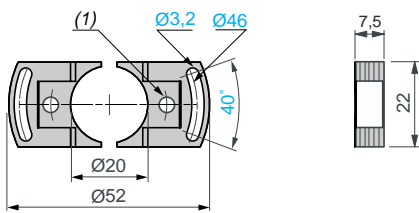

### XCC RF5N

Mounting on Ø 58 mm encoders XCC 1514T, XCC 2514T and XCC 3514T

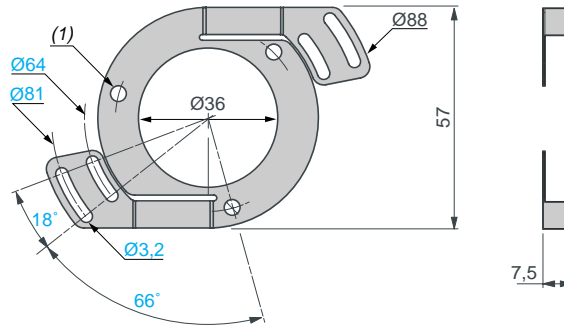

(1) 2 holes Ø 4 at 180° on 30 PCD. TC M4 x 5 screw fixings.

(1) 3 holes Ø 4.1 at 120° on 48 PCD. TC M3 x 6 screw fixings.

### XCC RF9

Mounting on Ø 90 mm encoders XCC 1930T, XCC 2930T and XCC 3930T

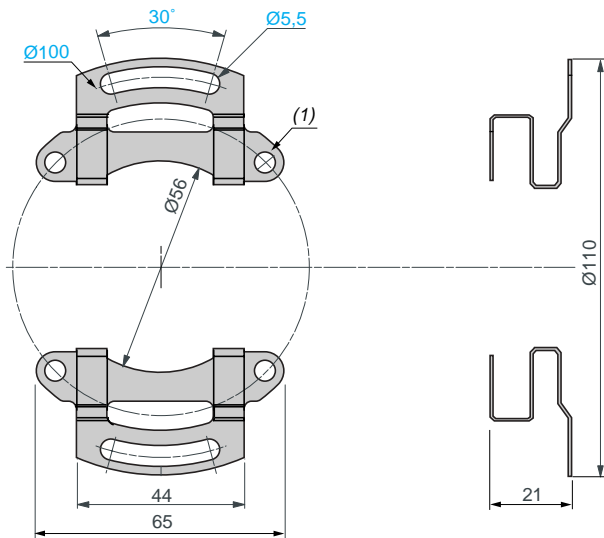

(1) 4 holes Ø 5.2 at 90° on 78 PCD. TH M5 x 6 screw fixings.

## Collar kits

### XCC RB1

Collar for synchro mounting, for Ø 58 encoders:  
XCC 15●●P, XCC 25●●P and XCC 35●●P

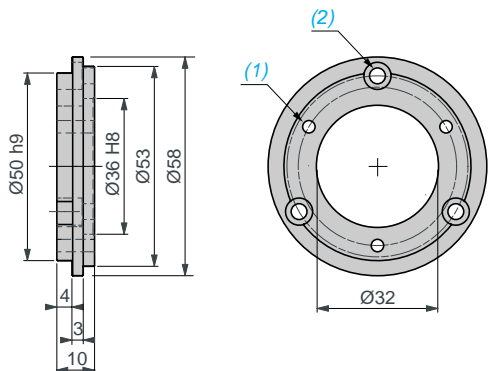

(1) 3 holes M4 x 0.7 at 120° on 42 PCD. TC M3 x 8 screw fixings.

(2) 3 counterbored holes for TC M4 x 8 screws at 120° on 48 PCD.

### XCC RB2

Interface collar for Ø 90 encoders:  
XCC 1912P, XCC 2912P and XCC 3912P

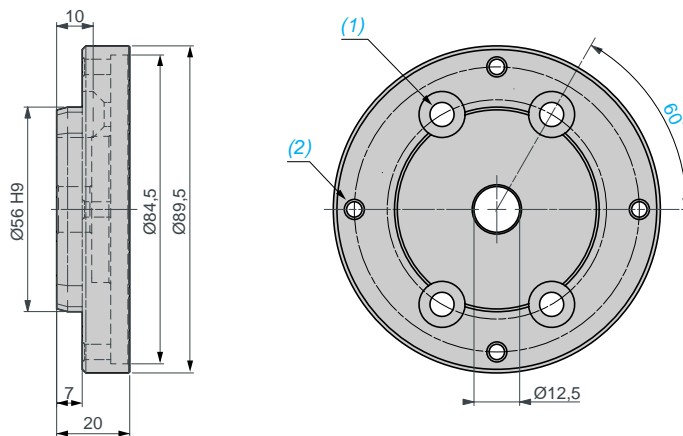

(1) 4 holes Ø 6.6 at 120° on 60 PCD. Countersunk for TZ M6 x 16 screws.

(2) 4 holes M5 x 0.8 at 90° on 78 PCD.

### XCC RB3

IP 67 sealed collar for Ø 58 encoders:  
XCC 1510P, XCC 2510P and XCC 3510P

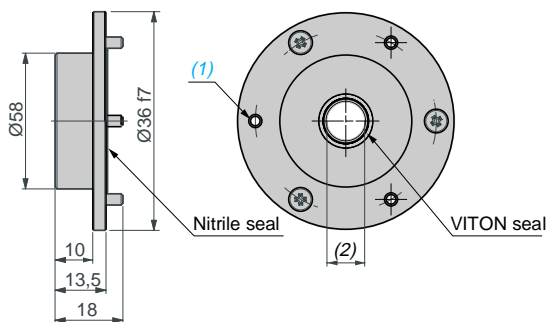

(1) 3 holes M3 x 0.5 at 120° on 48 PCD. TZ M3 x 8 screw fixings.

(2) Shaft Ø 10 mm.

Plain brackets

XCC RE5SN

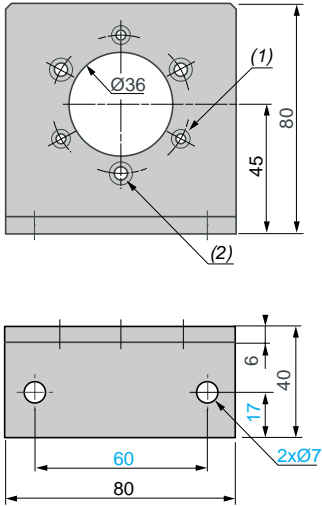

XCC RE9SN

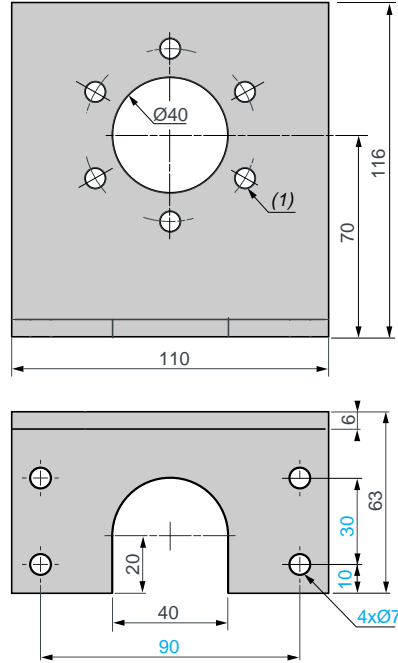

(1) 3 counterbored holes for CHC M3 screws at  $120^\circ$  on 48 PCD. (1) 6 holes  $\varnothing 7$  at  $60^\circ$  on 60 PCD for CHC M6 screws.  
(2) 3 counterbored holes for CHC M4 screws at  $120^\circ$  on 48 PCD.

Brackets with play compensator

XCC RE5RN

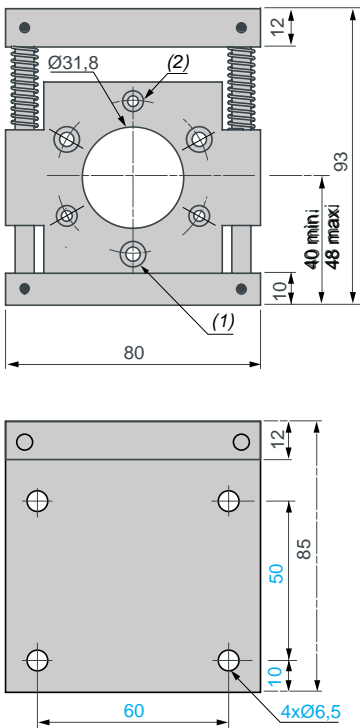

XCC RE9RN

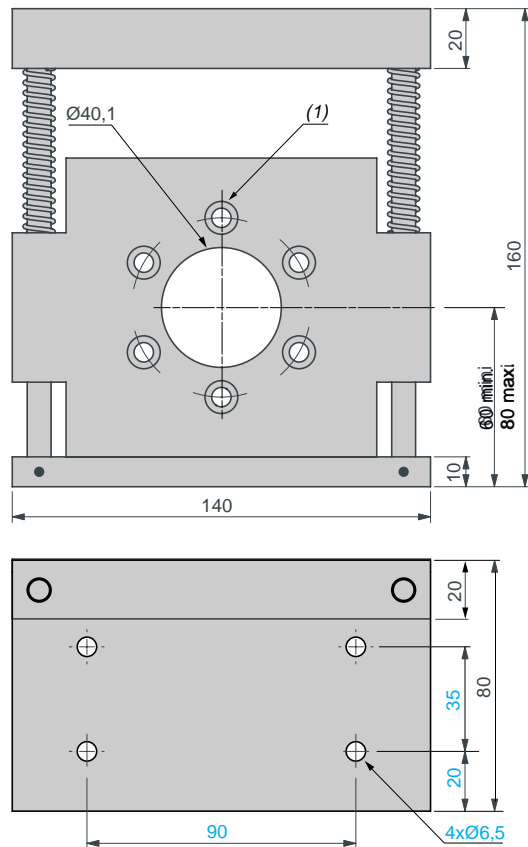

(1) 3 counterbored holes for CHC M3 screws at  $120^\circ$  on 48 PCD. (1) 6 counterbored holes for CHC M6 screws at  $120^\circ$  on 60 PCD.  
(2) 3 counterbored holes for CHC M4 screws at  $120^\circ$  on 48 PCD.

## Reduction collars for through shaft

### XCC R158RDA●●

For Ø 58 incremental and absolute single turn and multiturn encoders

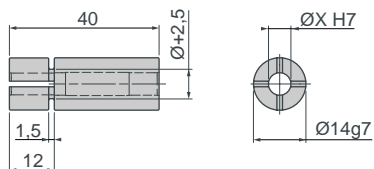

XCC	Ø
R158RDA06	6
R158RDA08	8
R158RDA10	10
R158RDA12	12

### XCC R290RDP●●

For Ø 90 incremental and absolute single turn encoders

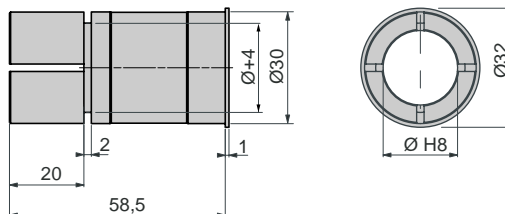

XCC	Ø
R290RDP12	12
R290RDP20	20
R290RDP25	25

### XCC R390RDP●●

For Ø 90 absolute multiturn encoders

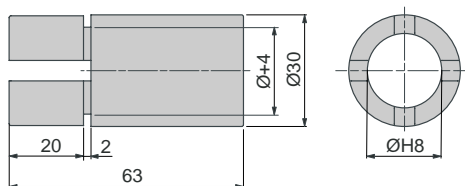

XCC	Ø
R390RDP16	16
R390RDP20	20
R390RDP25	25

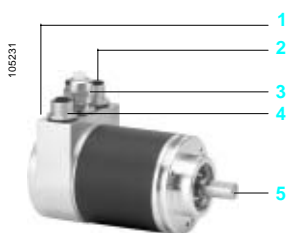

- 1 2 LEDs
- 2 M12 male connector (CANopen incoming bus)
- 3 PG9 connection for supply cable
- 4 M12 female connector (CANopen outgoing bus)
- 5 Encoder shaft

## Presentation

The Osicoder® CANopen multiturn absolute Ø 58 mm encoder is designed to cater for configurations encountered in communicating industrial installations. Models XCC 3510PS84CB and XCC3515CS84CB integrate CANopen communication protocols as standard.

The CAN-Bus interface integrated in the absolute rotary encoder supports all CANopen functions. The following modes can be programmed and made operational or stopped: Pooling mode, Cyclic mode and Sync mode. The application specific protocol supports the programming of the following additional functions:

- code sequence,
- resolution per revolution,
- global resolution,
- presets,
- speed and address.

The connection housing assures simple assembly and addressing. It performs the function of a T coupler and has M12 connectors for the bus incoming and outgoing signals.

The rotary encoder can be supplied via the CANopen bus or by using the dedicated PG9 cable gland. The address of the equipment is adjusted from the rotary switches. Encoders XCC 3510PS84CB and XCC 3515CS84CB have 2 LEDs located on the rear face of the housing to facilitate monitoring and diagnostics conforming to standard DR303-3 v1.2.1.0 (CIA). The LEDs provide information regarding the operative mode, bus errors, supply problems.

## Standards

Encoders XCC 3510PS84CB and XCC3515CS84CB conform to:

- standard ISO 11898,
- specifications DS301 V4.02/CAN2.A, DS406 V3.1, DR303-1V1.3, DR303-3 V1.2.

They are CiA certified and meet the requirements of the Schneider Electric interoperability standards.

## Encoder setting-up/configuration software

The CANopen bus is configured with the aid of SyCon version 2.9 software, reference SYC SPU LF.

To be ordered separately.

The EDS file, reference TEXCC35CB\_0100E.eds, required for encoder configuration is available and downloadable from our site [www.telemecanique.com](http://www.telemecanique.com).

## Configurable parameters

### ■ Transmission speed

Default value: 250 Kbaud, configurable from 10 Kbaud (distance 6700 m) to 1 Mbaud (distance 40 m).

### ■ Address

defines encoder identification on the bus, 1 to 89. Default value: id = 1. It is defined using 2 coding wheels located in the housing.

### ■ Resolution

defines the number of points per revolution (0 to 8191)

### ■ Global resolution

defines the total number of codes of the encoder (0 to 33 554 431)

### ■ Direction

enables defining of the counting direction of the encoder (increasing clockwise or anticlockwise) in relation to its mechanical position

### ■ Reset to X

defines the value of its actual position (reset to X or reset to amount).

## Communication modes

### ■ Pooling mode

The encoder responds to requests from the master. This mode enables programming and referring to the encoder parameters whilst in position.

### ■ Cyclic mode

The encoder transmits its position cyclically. The transmission period is programmable from 0 to 65535 ms.

### ■ Sync mode

The encoder transmits its position when requested by the master synchro.

<b>Characteristics</b>				
<b>Encoder type</b>			<b>XCC 3510PS84CB</b>	<b>XCC 3515CS84CB</b>
<b>Conformity</b>			C €	
<b>Temperature</b>	Operation (housing)	°C	- 40...+ 85	
	Storage	°C	- 40...+ 85	
<b>Degree of protection</b>	Conforming to IEC 60529		IP 64	
<b>Vibration resistance</b>	Conforming to IEC 60068-2-6		10 gn (f = 10...2 kHz)	
<b>Shock resistance</b>	Conforming to IEC 60068-2-27		100 gn (6 ms, 1/2 sine wave)	
<b>Resistance to electromagnetic interference</b>	Electrostatic discharges		Conforming to IEC 61000-4-2: level 2, 4 kV air; 2 kV contact	
	Radiated electromagnetic fields (electromagnetic waves)		Conforming to IEC 61000-4-3: level 3, 10 V/m	
	Fast transients (Start/Stop interference)		Conforming to IEC 61000-4-4: level 3, 2 kV (1 kV for inputs/outputs)	
	Surge withstand		Conforming to IEC 61000-4-5: level 1, 500 V	
<b>Materials</b>	Base		Aluminium	
	Housing		Aluminium	
	Shaft		Stainless steel	
	Ball bearings		6000ZZ1	6803ZZ
<b>Mechanical characteristics</b>				
<b>Shaft type</b>		<b>mm</b>	Ø 10, solid shaft (h8)	Ø 15, hollow shaft (F7)
<b>Maximum rotational speed</b>	Continuous		6000 rpm	
<b>Shaft moment of inertia</b>		<b>g.cm<sup>2</sup></b>	30	
<b>Torque</b>		<b>N.cm</b>	0.3	
<b>Maximum load</b>	Radial	<b>daN</b>	11	
<b>Electrical characteristics</b>				
<b>Connection</b>	Connector		CANopen bus network by M12 connector (input: male; output: female), 5-pin, A coding. Supply via PG9 of each encoder or via the bus	
<b>Frequency</b>		<b>kHz</b>	800	
<b>Supply</b>	Nominal voltage	<b>V</b>	24 (10-30)	
<b>Current consumption, no-load</b>		<b>mA</b>	100 max.	
<b>Protection</b>			Against reverse polarity and voltage peaks	
<b>Signalling</b>			Green LED: CAN_RUN; red LED: CAN_ERR	
<b>Communication</b>				
<b>CANopen service</b>	Conformity class		S10 (Transparent Ready)	
	Profile		DS406 V3.1, class C2	
	Specifications		ISO 11898, DS301 V4.02/CAN2.A, DR303-1V1.3, DR303-3 V1.2.	
<b>Structure</b>	Speed	<b>Kbps/s</b>	10, 20, 50, 125, 250, 500, 800 and 1000	
<b>Product certification</b>			CiA Schneider Electric interoperability standards	

102231



XCC 3510PS84CB

102232



XCC 3515CS84CB

596488

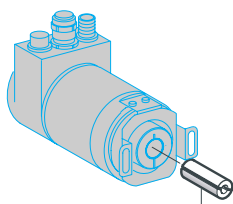

XCC R358RDL●●

100507



TSX CAN CA●●

805999

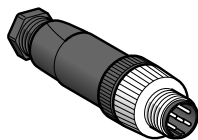

XZ CC12●●M50B

806000

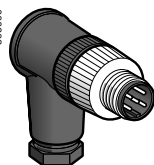

XZ CC12●●M50B

## CANopen Ø 58 mm encoders

Description	Connection method	Output stage type	Supply voltage	Reference	Weight kg
<b>Solid shaft, Ø 10 mm</b>					
Ø 58 mm multiturn absolute CANopen Bus encoders Resolution 8192 pts/ 4096 turns	Radial 2 x M12 connectors A coding 1 x PG9	CANopen, 25-bit, binary	11...30 V	<b>XCC 3510PS84CB</b>	0.560

## Hollow shaft, Ø 15 mm (1)

Ø 58 mm multiturn absolute CANopen Bus encoders Resolution 8192 pts/ 4096 turns	Radial 2 x M12 connectors A coding 1 x PG9	CANopen, 25-bit, binary	11...30 V	<b>XCC 3515CS84CB</b>	0.570
--	---	-------------------------	-----------	-----------------------	-------

## Hollow shaft, Ø 6, 8, 10 and 14 mm (1)

Encoder type	Diameter mm	Reduction collar to be ordered (see page 50)
Encoders with hollow shaft XCC 3515CS84CB	Ø 6	<b>XCC R358RDL06</b>
	Ø 8	<b>XCC R358RDL08</b>
	Ø 10	<b>XCC R358RDL10</b>
	Ø 12	<b>XCC R358RDL12</b>
	Ø 14	<b>XCC R358RDL14</b>

## Connection accessories for CANopen bus

### Connecting cables for CANopen bus

Description	Length m	Reference	Weight kg
Connecting cables fitted with 2 elbowed type M12 connectors, A coding	0.3	<b>FTX CN3203</b>	0.040
	0.6	<b>FTX CN3206</b>	0.070
	1	<b>FTX CN3210</b>	0.100
	2	<b>FTX CN3220</b>	0.160
	3	<b>FTX CN3230</b>	0.220
	5	<b>FTX CN3250</b>	0.430

### CANopen cables

Description	Length	Unit reference	Weight kg
Standard CANopen cables conforming to IEC 60 332-1	50 m	<b>TSX CAN CA50</b>	—
	100 m	<b>TSX CAN CA100</b>	—
	300 m	<b>TSX CAN CA300</b>	—

### Connectors

Description	Type	Unit reference	Weight kg
<b>M12 female connector</b> 5 screw terminals	Straight	<b>XZ CC12FDM50B</b>	0.020
	Elbowed	<b>XZ CC12FCM50B</b>	0.020
<b>M12 male connector</b> 5 screw terminals	Straight	<b>XZ CC12MDM50B</b>	0.025
	Elbowed	<b>XZ CC12MCM50B</b>	0.025

(1) Anti-rotation device included with encoder.

**CANopen Ø 58 mm encoders**

XCC 3510PS84CB

XCC 3515CS84CB

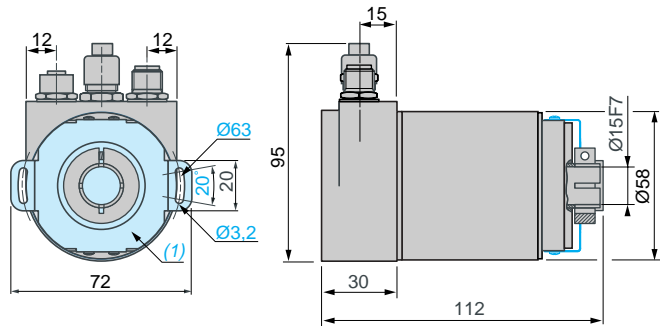
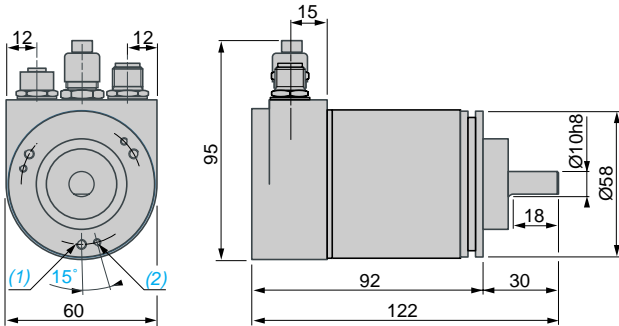

(1) 3 M4 holes at 120° on 48 PCD, depth: 6 mm.  
(2) 3 M3 holes at 120° on 48 PCD, depth: 6 mm.

(1) Flexible mounting kit, 1 x XCC RF5B mounted.

**Connection**

**CANopen**

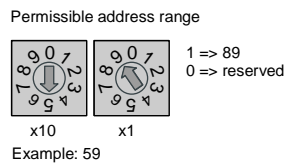
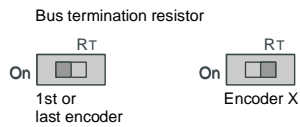
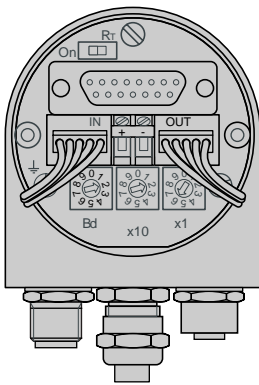

Bus IN  
M12 male connector



Bus OUT  
M12 female connector

Pin	1	2	3	4	5
Function	CAN_SHLD (CAN_V+)	CAN_GND	CAN_H	CAN_L	
Terminal	+	-			
Function	24 V	0 V			

# Multiturn absolute encoders on bus

## Osicoder®

### PROFIBUS-DP Ø 58 mm encoders

#### Presentation

The Osicoder® PROFIBUS-DP multiturn absolute Ø 58 mm encoder is designed to cater for configurations encountered in communicating industrial installations. Models XCC 3510PV84FB and XCC3515CV84FB integrate PROFIBUS-DP communication protocols as standard.

The PROFIBUS-DP bus interface integrated in the absolute rotary encoder is based on RS 485 transmission and enables speeds of up to 12Mbps. Exchanges are possible between the master and the encoder as well as between encoders. The application specific protocol DP-V2 conforms to the class 2 profile for encoders and supports the following functions:

- code sequence,
- resolution per revolution,
- global resolution,
- presets,
- soft stops,
- speed and address.

The housing of the encoders provides easy access to 2 coding wheels for configuration of the address. 2 LEDs are integrated to facilitate diagnostics. It performs the function of a T coupler with 3 x PG9 cable glands (2 for the bus incoming and outgoing signals, 1 for the encoder supply).

PROFIBUS-DP encoders have 2 LEDs to indicate the encoder status:

- Green LED: "Sta"
- Red LED: "Err".

#### Standards

PROFIBUS-DP encoders XCC 3510PV84FB and XCC3515CV84FB conform to:

- international standards IEC 61158 and IEC 61784 for PROFIBUS-DP communication
- the PROFIBUS-DP standard EN50170 Class 2 in accordance with profile 3.062 V 1.1 for the encoder application.

They are certified by the PNO organisation and meet the requirements of the Schneider Electric interoperability standards.

#### Encoder setting-up/configuration software

The PROFIBUS-DP bus is configured with the aid of SyCon version 2.9 software, reference SYC SPU LF. To be ordered separately.

The GSD file, reference TELE4711.gsd, required for encoder configuration is available and downloadable from our site [www.telemecanique.com](http://www.telemecanique.com).

#### Configurable parameters

##### ■ Speed

defines the instantaneous speed in 16 bit binary. It can be data according to 1 of 4 modes:

- Steps/10 ms
- Steps/100 ms
- Steps/s or rpm.

##### ■ Address

Addressing is performed using 2 rotary switches located in the housing. The addresses possible are 1 to 99.

##### ■ Resolution

defines the number of points per revolution (0 to 8191)

##### ■ Global resolution

defines the total number of codes of the encoder (0 to 33 554 431)

##### ■ Direction

enables defining of the counting direction of the encoder (increasing clockwise or anticlockwise) in relation to its mechanical position

##### ■ 2 soft stops

one high stop and one low stop can be defined and extracted from the position word

##### ■ Reset to X

defines the value of its actual position (reset to X or reset to amount).

#### Communication modes

2 communication modes are possible:

- simple and fast, cyclic and deterministic exchanges between the master and the encoder,
- acyclic exchanges.

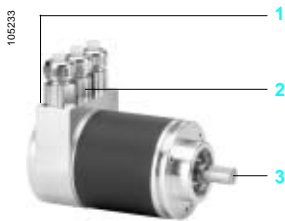

- 1 2 LEDs
- 2 PG9 connection for supply cable
- 3 Encoder shaft

Characteristics			
Encoder type		XCC 3510PV84FB	XCC 3515CV84FB
Conformity		DIN VDE 0160	
Temperature	Operation (housing)	°C	- 40...+ 85
	Storage	°C	- 40...+ 85
Degree of protection	Conforming to IEC 60529	IP 64	
Vibration resistance	Conforming to IEC 60068-2-6	10 gn (f = 10...2 kHz)	
Shock resistance	Conforming to IEC 60068-2-27	100 gn (6 ms, 1/2 sine wave)	
Resistance to electromagnetic interference	Electrostatic discharges	Conforming to IEC 61000-4-2: level 2, 4 kV air; 2 kV contact	
	Radiated electromagnetic fields (electromagnetic waves)	Conforming to IEC 61000-4-3: level 3, 10 V/m	
	Fast transients (Start/Stop interference)	Conforming to IEC 61000-4-4: level 3, 2 kV (1 kV for inputs/outputs)	
	Surge withstand	Conforming to IEC 61000-4-5: level 1, 500 V	
Materials	Base	Aluminium	
	Housing	Aluminium	
	Shaft	Stainless steel	
	Ball bearings	6000ZZ1	6803ZZ
Mechanical characteristics			
Shaft type	mm	Ø 10, solid shaft (h8)	Ø 15, hollow shaft (F7)
Maximum rotational speed		6000 rpm	
Shaft moment of inertia	g.cm <sup>2</sup>	30	
Torque	N.cm	0,3	
Maximum load	Radial	daN	11
Electrical characteristics			
Connection	PG9	3 x PG9 inputs: - 2 x PG9 inputs for the PROFIBUS-DP bus - 1 x PG9, positioned in middle, for external supply (10-30 V) Due to the T integrated in the housing, the supply can be distributed on the bus.  Connections are made using screw terminals.	
Frequency		kHz	800
Supply	Nominal voltage	V	24 (10-30)
Current consumption, no-load		mA	100
Protection		Against reverse polarity and voltage peaks	
Signalling		Green LED: "Sta"; red LED: "Err"	
Communication			
PROFIBUS-DP V2 service	Profile for encoder Specifications	3.062 V1.1. IEC 61158, IEC 61784, EN 50170 class 2, EN 50254	
Interface		RS 485	
Speed		9.6 Kbps...12 Mbps max.	
Product certification		PNO Schneider Electric interoperability standards	

# Multiturn absolute encoders on bus

## Osicoder®

### PROFIBUS-DP Ø 58 mm encoders

105233



XCC 3510PV84FB

105238



XCC 3515CV84FB

56468

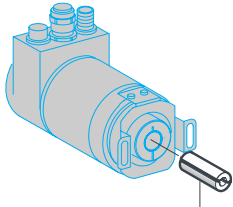

XCC R358RDL●●

#### References

Description	Connection method	Output stage type	Supply voltage	Reference	Weight kg
-------------	-------------------	-------------------	----------------	-----------	-----------

#### Solid shaft, Ø 10 mm

Ø 58 mm multiturn absolute PROFIBUS-DP encoders Resolution 8192 pts/4096 turns	3 x PG9 radial	PROFIBUS-DP, 25-bit, binary	11...30 V	<b>XCC 3510PV84FB</b>	0.560
---	----------------	-----------------------------	-----------	-----------------------	-------

#### Hollow shaft, Ø 15 mm (1)

Ø 58 mm multiturn absolute PROFIBUS-DP encoders Resolution 8192 pts/4096 turns	3 x PG9 radial	PROFIBUS-DP, 25-bit, binary	11...30 V	<b>XCC 3515CV84FB</b>	0.570
---	----------------	-----------------------------	-----------	-----------------------	-------

#### Hollow shaft, Ø 6, 8, 10 and 14 mm (1)

Encoder type	Diameter mm	Reduction collar to be ordered (see page 50)
Encoders with hollow shaft XCC 3515CV84FB	Ø 6	<b>XCC R358RDL06</b>
	Ø 8	<b>XCC R358RDL08</b>
	Ø 10	<b>XCC R358RDL10</b>
	Ø 12	<b>XCC R358RDL12</b>
	Ø 14	<b>XCC R358RDL14</b>

(1) Anti-rotation device included with encoder.

**PROFIBUS-DP Ø 58 mm encoders**

XCC 3510PV84FB

XCC 3515CV84FB

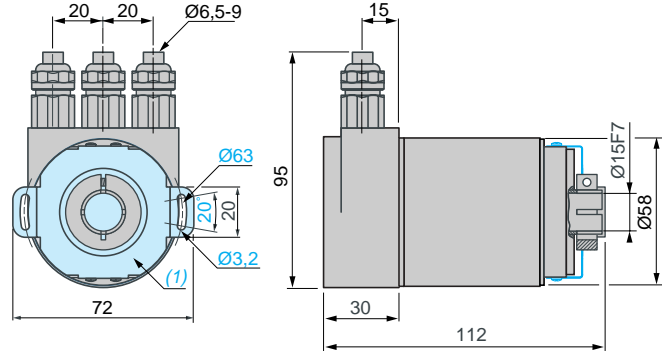
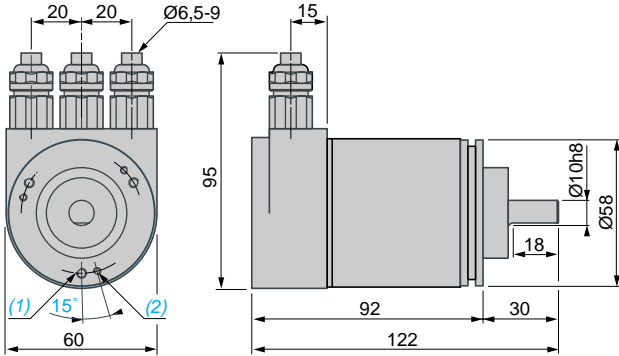

(1) 3 M4 holes at 120° on 48 PCD, depth: 6 mm.  
(2) 3 M3 holes at 120° on 48 PCD, depth: 6 mm.

(1) Flexible mounting kit, 1 x XCC RF5B mounted.

**Connection**

PROFIBUS-DP

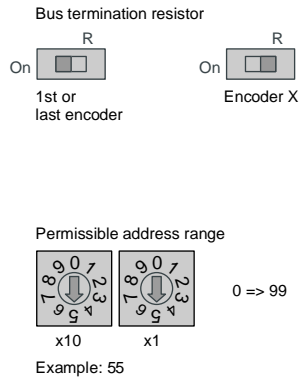
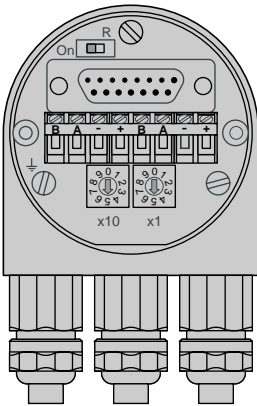

Terminal	⏚	B (left)	A (left)	-	+
Function	Earth	Bus line B (Bus in)	Bus line A (Bus in)	0 V	11-30 V
Terminal		B (right)	A (right)	-	+
Function		Bus line B (Bus out)	Bus line A (Bus out)	0 V	11-30 V

### Shaft couplings with spring (1)

Maximum torque	N.cm	300
Maximum angular misalignment		5°
Maximum radial misalignment	mm	± 1.5
Materials	Collars	Zamak
	Spring	Nickel plated steel
Compression/Expansion	mm	± 1 max.

### Homokinetic (flexible) shaft couplings with bellows

Maximum torque	N.cm	80
Maximum angular misalignment		4°
Maximum lateral misalignment	mm	± 0.3
Maximum axial misalignment	mm	± 0.5
Materials	Bellows	Stainless steel
	Fixing collar	Aluminium
	Screws	Stainless steel

(1) Not recommended for resolutions higher than 500 points.

### References

105191



XCC RAR●●●

105192



XCC RAS●●●●

105188



XCC R358RDL06

#### Shaft couplings (for encoders with solid shaft)

Type	Bore diameter (encoder side)	Bore diameter (machine side)	Reference	Weight kg
With spring (2)	10 mm	8 mm	XCC RAR1008	0.120
		10 mm	XCC RAR1010	0.120
		12 mm	XCC RAR1012	0.110
		14 mm	XCC RAR1014	0.110
		16 mm	XCC RAR1016	0.105
Homokinetic (flexible) with bellows	10 mm	8 mm	XCC RAS1008	0.015
		10 mm	XCC RAS1010	0.015
		12 mm	XCC RAS1012	0.015

#### Anti-rotation devices (for encoders with hollow shaft)

Description	Features	For encoders	Reference	Weight kg
Flexible mounting kit	1 flexible fixing + screws	CANopen and PROFIBUS-DP	XCC RF5B	0.010

#### Reduction collars for encoders with hollow shaft

Description	For use with	Reduction	Reference	Weight kg
Reduction collars	CANopen and PROFIBUS-DP encoders	15 to 6	XCC R358RDL06	0.040
		15 to 8	XCC R358RDL08	0.030
		15 to 10	XCC R358RDL10	0.025
		15 to 12	XCC R358RDL12	0.020
		15 to 14	XCC R358RDL14	0.010

(2) Not recommended for resolutions higher than 500 points.

## Shaft couplings

### XCC RAR●●●●

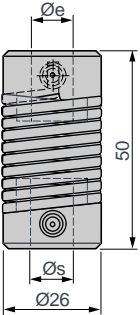

XCC	Ø e	Ø s
RAR1008	10	8
RAR1010	10	10
RAR1012	10	12
RAR1014	10	14
RAR1016	10	16

### XCC RAS●●●●

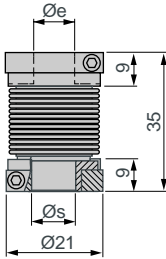

XCC	Ø e	Ø s
RAS1008	10	8
RAS1010	10	10
RAS1012	10	12

## Anti-rotation device

### XCC RF5B

Mounting on Ø 58 mm CANopen and PROFIBUS-DP encoders XCC 3510●●●●FB, XCC 3510●●●●CB, XCC 3515C●●●●FB, XCC 3515C●●●●CB

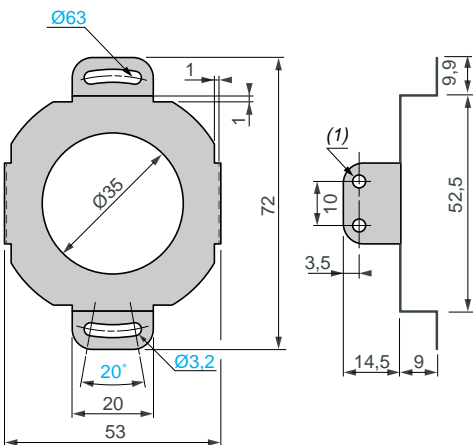

(1) 4 holes Ø 3.2. M3 x 6 screw fixings.

## Reduction collars

### XCC R358RDL●●

For CANopen and PROFIBUS-DP encoders

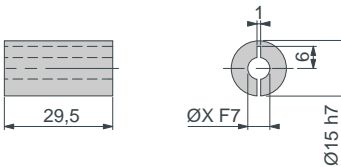

XCC	Ø
R358RDL06	6
R358RDL08	8
R358RDL10	10
R358RDL12	12
R358RDL14	14

# The efficiency of Telemecanique branded *solutions*

Used in combination, Telemecanique products provide quality solutions, meeting all your **Automation & Control** applications requirements.



## A **worldwide** presence

### Constantly available

- More than 5 000 points of sale in 130 countries.
- You can be sure to find the range of products that are right for you and which complies fully with the standards in the country where they are used.

### Technical assistance wherever you are

- Our technicians are at your disposal to assist you in finding the optimum solution for your particular needs.
- Schneider Electric provides you with all necessary technical assistance, throughout the world.



### Schneider Electric Industries SAS

Head Office  
89, bd Franklin Roosevelt  
92506 Rueil-Malmaison Cedex  
France

[www.schneider-electric.com](http://www.schneider-electric.com)  
[www.telemecanique.com](http://www.telemecanique.com)

Due to evolution of standards and equipment, the characteristics indicated in texts and images of this document do not constitute a commitment on our part without confirmation.

Design: Schneider Electric  
Photos: Schneider Electric  
Printed by:

*Simply Smart !*

DIA4ED2051202EN